

CITY OF BERKELEY ALAMEDA COUNTY, CALIFORNIA BERKELEY MARINA DOCK REPLACEMENT (D-E)

PROJECT PRWT122013
SPECIFICATION NO. 32000261

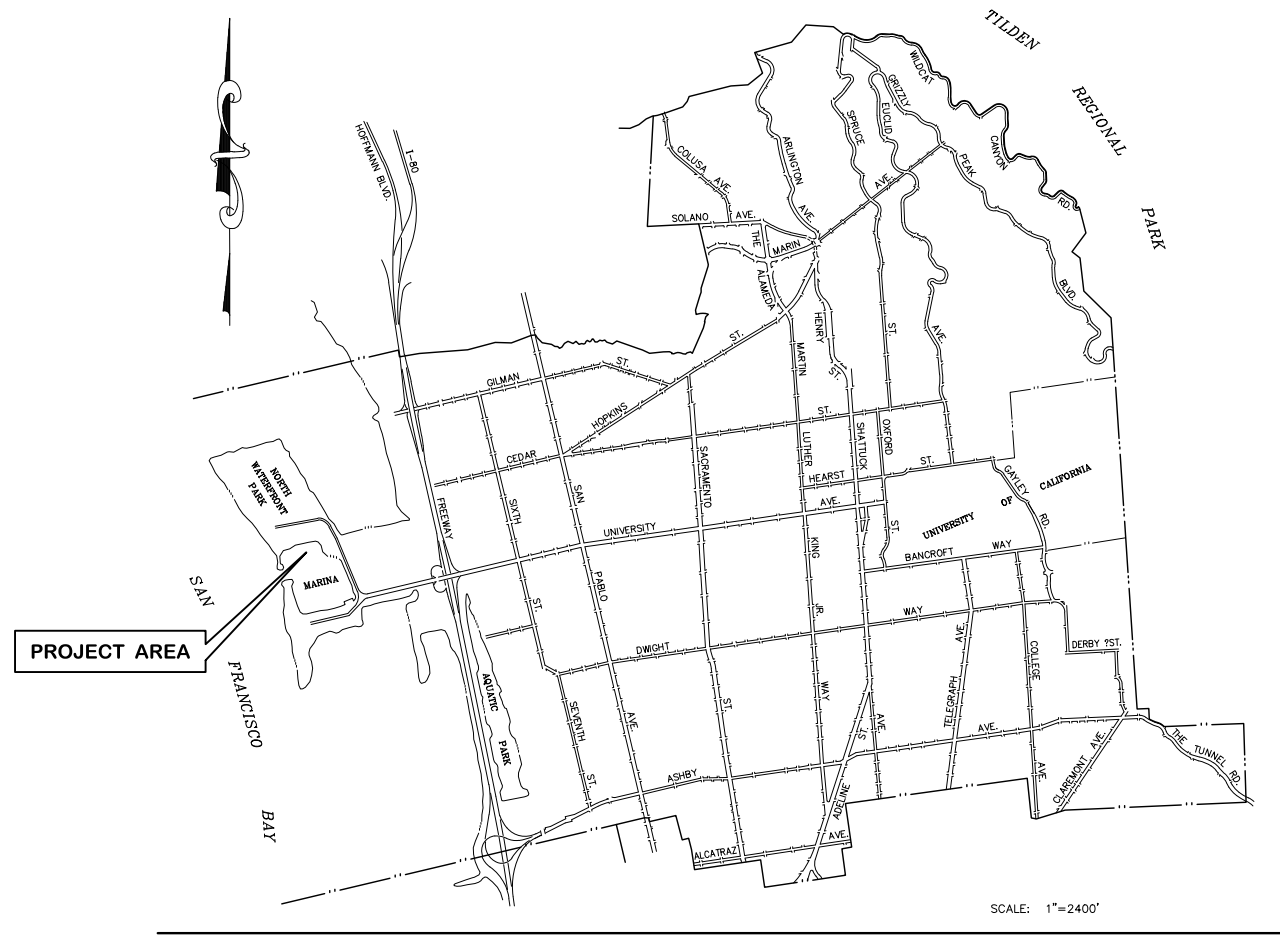

LOCATION MAP

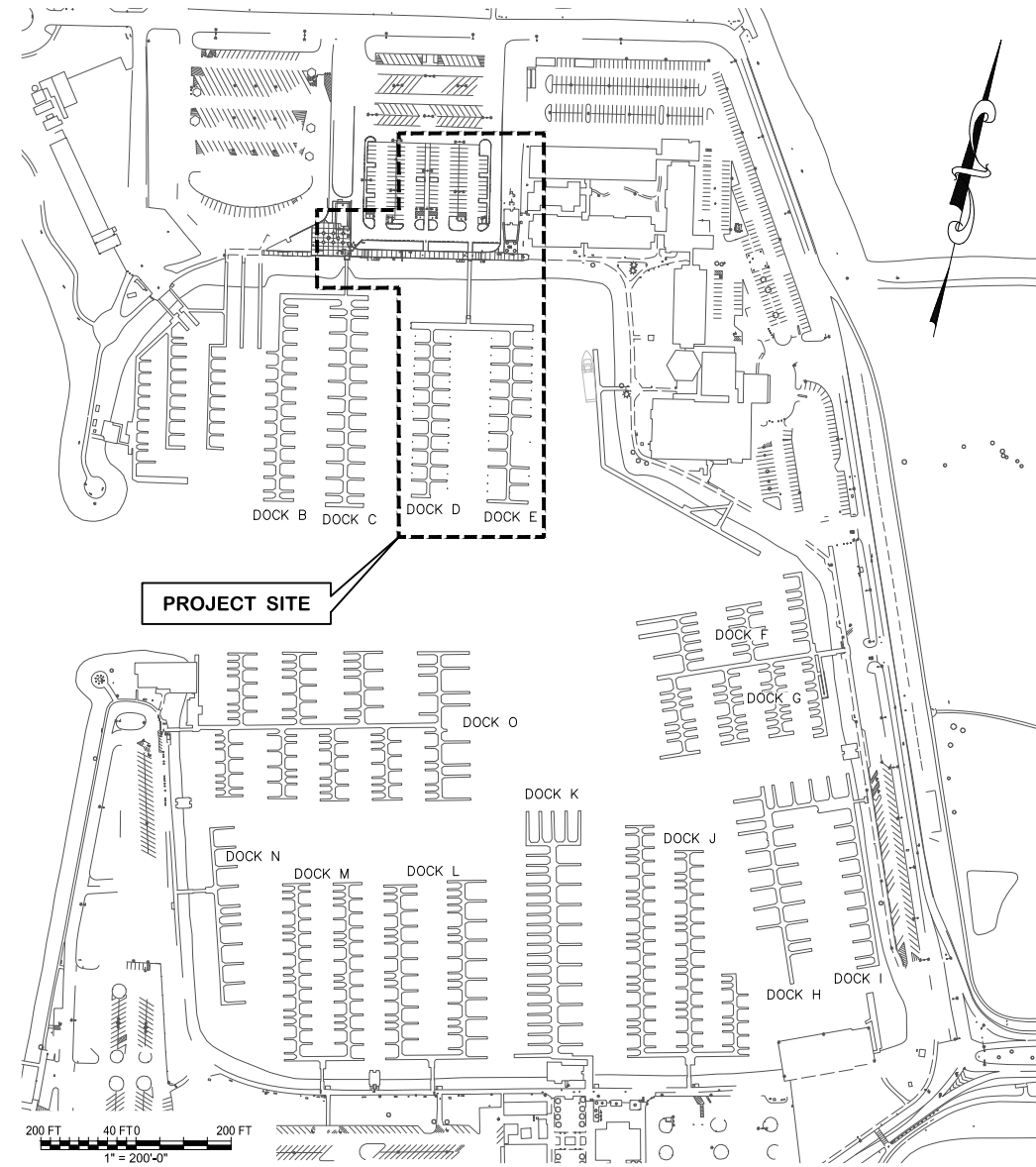

PROJECT LOCATION MAP

PROJECT MANAGER: _____	DATE: _____	DEPICTION OF MONUMENTS: _____	DATE: _____
SURVEY PARTY CHIEF: _____		SUPERVISING CIVIL ENGINEER: _____	
WATERSHED REVIEW: _____		APPROVED: _____	
DATE: _____		DATE: _____	
FOR REDUCED PLANS - ORIGINAL SCALE IS IN INCHES		CITY ENGINEER: _____	



BERKELEY MARINA DOCK REPLACEMENT (D-E)
CITY OF BERKELEY, ALAMEDA COUNTY, CALIFORNIA
COVER PAGE

REVISION	MARK	DATE	DESCRIPTION	APPROVAL
C		05-12-2023	50% PROGRESS SUBMITTAL	JMC
B		03-27-2023	60% PROGRESS SUBMITTAL	JMC
A		08-03-2022	30% PROGRESS SUBMITTAL	JMC

DRAFT 90% Submittal

DRAWING INDEX

NO	SHEET NO.	DESCRIPTION	REVISION
GENERAL			
1	G-001	COVER PAGE	C
2	G-002	SHEET INDEX AND ABBREVIATIONS	C
3	G-003	BASIS OF DESIGN AND SPECIAL INSPECTION - SHEET 1 OF 2	C
4	G-004	BASIS OF DESIGN AND SPECIAL INSPECTION - SHEET 2 OF 2	B
5	G-005	PROJECT LIMITS AND CONTRACTOR LAYDOWN AREA	C
DEMOLITION			
6	D-100	DEMOLITION - SHEET 1 OF 2	C
7	D-101	DEMOLITION - SHEET 2 OF 2	C
8	D-102	DEMOLITION - SECTIONS	B
CIVIL			
9	C-100	LANDSIDE IMPROVEMENT PLAN	B
10	C-101	SECTIONS	B
11	C-102	LANDSCAPE DETAILS	B
12	C-103	GATE DETAILS - SHEET 1 OF 2	B
13	C-104	GATE DETAILS - SHEET 2 OF 2	B
14	C-105	RESTROOM FENCE RELOCATION PLAN AND MISCELLANEOUS DETAILS	B
STRUCTURAL			
15	S-001	SITE PLAN	C
16	S-100	GANGWAY DETAILS - SHEET 1 OF 2	C
17	S-101	GANGWAY DETAILS - SHEET 2 OF 2	C
18	S-110	NEW DOCK PLAN	C
19	S-120	FLOAT DETAILS - SHEET 1 OF 6	C
20	S-121	FLOAT DETAILS - SHEET 2 OF 6	C
21	S-122	FLOAT DETAILS - SHEET 3 OF 6	B
22	S-123	FLOAT DETAILS - SHEET 4 OF 6	B
23	S-124	FLOAT DETAILS - SHEET 5 OF 6	C
24	S-125	FLOAT DETAILS - SHEET 6 OF 6	C
25	S-130	GUIDE PILE DETAILS	C
26	S-141	ACCESSORY DETAILS - SHEET 1 OF 2	B
27	S-142	ACCESSORY DETAILS - SHEET 2 OF 2	C
ELECTRICAL			
28	E-001	ELECTRICAL LEGEND, ABBREVIATIONS, AND GENERAL NOTES	C
29	E-002	SITE PLAN DOCK D & E	C
30	E-003	ELECTRICAL PLAN DEMOLITION WORK DOCK D & E	C
31	E-004	ELECTRICAL CONSTRUCTION STAGING AREA	B
32	E-101	NEW SINGLE LINE DIAGRAM D & E	C
33	E-201	ELECTRICAL SITE PLAN NEW WORK D & E	C
34	E-202	PLAN - DOCK D & E SHEET 1 OF 2	B
35	E-203	PLAN - DOCK D & E SHEET 2 OF 2	B
36	E-204	PLAN AND LANDSIDE PHOTOS - DOCK D & E	B
37	E-401	ELECTRICAL DETAILS SHEET 1 OF 2	B
38	E-402	ELECTRICAL DETAILS SHEET 2 OF 2	B
39	E-501	ELECTRICAL PANEL SCHEDULES	B
40	E-502	ELECTRICAL LOAD CALCULATIONS	A
FIRE PROTECTION			
42	FP-001	FIRE PROTECTION GENERAL NOTES, LEGEND, AND ABBREVIATIONS	C
42	FP-201	FIRE PROTECTION PLAN - NEW WORK DOCK D & E	C
43	FP-301	FIRE PROTECTION SECTIONS	A
44	FP-302	FIRE PROTECTION SECTIONS	A
45	FP-401	FIRE PROTECTION GENERAL NOTES, LEGEND, AND ABBREVIATIONS	A
PLUMBING			
46	P-001	PLUMBING GENERAL NOTES, LEGEND, AND ABBREVIATIONS	C
47	P-101	PLUMBING PLAN DEMOLITION WORK DOCK D & E	C
48	P-201	PLUMBING PLAN NEW WORK DOCK D & E	C
49	P-301	PLUMBING SECTIONS	A
50	P-302	PLUMBING SECTIONS	A
51	P-401	PLUMBING DETAILS	A
ETRAC TOPOGRAPHIC REFERENCE DRAWINGS			
52	S1	PROJECT INFORMATION	
53	S2	ELEVATION CONTOURS	
54	S3	SITE FEATURES	
ETRAC HYDROGRAPHIC REFERENCE DRAWINGS			
55	S1	PROJECT INFORMATION	
56	S2	SOUNDINGS	
57	S3	SOUNDINGS	
58	S4	SOUNDINGS	
59	S5	SOUNDINGS	
60	S6	SOUNDINGS	
61	S7	SOUNDINGS	
62	S8	COLORED DEM	
63	S9	COLORED DEM	
64	S10	COLORED DEM	
65	S11	COLORED DEM	

ABBREVIATIONS

<p>AB AGGREGATE BASE AC, A/C ASPHALTIC CONCRETE ASSOC ASSOCIATED BLDG BUILDING CODE BLVD BOULEVARD CB CATCH BASIN CC CENTER TO CENTER CCJ CRACK CONTROL JOINT CI CAST IRON CIP CAST-IN-PLACE CTR CENTER C, CL CENTER LINE CIR CIRCUIT CLR CLEAR CONC CONCRETE CND CONDUCTOR CONT CONTINUOUS CMP CORRUGATED METAL PIPE CY CUBIC YARD DBL DOUBLE DET DETAIL DF DOUGLAS FIR DI DROP INLET DIA DIAMETER EA EACH EW EACH WAY EL, ELEV ELEVATION EQ EQUAL EXT EXTERIOR (E) EXISTING F/C FACE OF CURB FD FLOOR DRAIN FHC FIRE HOSE CABINET FTG FOOTING FG FINISH GRADE FT FOOT GALV GALVANIZED GRS GALVANIZED RIGID STEEL GA GAUGE GB GRADE BREAK GLU LAM GLUE LAMINATED BEAM GR GROUND H/C HANDICAPPED</p>	<p>HP HIGH POINT HDG HOT DIPPED GALVANIZED HORIZ HORIZONTAL HB HOSE BIB INT INTERIOR INV INVERT J-BOX JUNCTION BOX LB POUND LF LINEAR FOOT LG SCR LAG SCREW MAX MAXIMUM MB MACHINE BOLT MCM THOUSAND CIRCULAR MILS MHW MEAN HIGH WATER MIN MINIMUM MDO MEDIUM DENSITY OVERLAY MH MANHOLE MSB MAIN SWITCH BOARD (N) NEW NIC NOT IN CONTRACT MIN NUMBER NTS NOT TO SCALE PS PRESSURE TREATED OC ON CENTER PG&E PACIFIC GAS & ELECTRIC PT POINT PVC, P.V.C. POLYVINYL CHLORIDE R RADIUS REINF REINFORCING REQD REQUIRED SCHD, SCH SCHEDULE S.A. SEE ARCHITECTURAL DRAWINGS S.E.J. SEE ELECTRICAL DRAWINGS S.M.D. SEE MECHANICAL DRAWINGS SF SQUARE FOOT SHT SHEET S/W SIDEWALK SIM SIMILAR STD STANDARD SD STORM DRAIN S.S. SANITARY SEWER</p>	<p>SS STAINLESS STEEL SDP STORM DRAIN PIPE SPEC SPECIFICATION STN STATION T/C TOP OF CURB TR TO REMAIN TYP TYPICAL UBC UNIFORM BUILDING UHMW ULTRA HIGH MOLECULAR WEIGHT VAR VARIES VERT VERTICAL W\M WELDED WIRE MESH W\ WITH @ AT ø DIAMETER</p>
--	---	--

DRAFT 90% Submittal

PLOTTED BY: NIEL FORTEZ PLOT DATE: 05/10/2023 11:08:54 AM

JMC	JMC	JMC	JMC	JMC	JMC	JMC	JMC	JMC	JMC
APPROVAL	APPROVAL	APPROVAL	APPROVAL	APPROVAL	APPROVAL	APPROVAL	APPROVAL	APPROVAL	APPROVAL
DATE	DATE	DATE	DATE	DATE	DATE	DATE	DATE	DATE	DATE
REVISION	REVISION	REVISION	REVISION	REVISION	REVISION	REVISION	REVISION	REVISION	REVISION
MARK	MARK	MARK	MARK	MARK	MARK	MARK	MARK	MARK	MARK
DESCRIPTION	DESCRIPTION	DESCRIPTION	DESCRIPTION	DESCRIPTION	DESCRIPTION	DESCRIPTION	DESCRIPTION	DESCRIPTION	DESCRIPTION
60% PROGRESS SUBMITTAL	60% PROGRESS SUBMITTAL	60% PROGRESS SUBMITTAL	60% PROGRESS SUBMITTAL	60% PROGRESS SUBMITTAL	60% PROGRESS SUBMITTAL	60% PROGRESS SUBMITTAL	60% PROGRESS SUBMITTAL	60% PROGRESS SUBMITTAL	60% PROGRESS SUBMITTAL
05-12-2023	03-27-2023	03-27-2023	03-27-2023	03-27-2023	03-27-2023	03-27-2023	03-27-2023	03-27-2023	03-27-2023
C	B	A	A	A	A	A	A	A	A
FILE	FILE	FILE	FILE	FILE	FILE	FILE	FILE	FILE	FILE
PLAN	PLAN	PLAN	PLAN	PLAN	PLAN	PLAN	PLAN	PLAN	PLAN
G-002	G-002	G-002	G-002	G-002	G-002	G-002	G-002	G-002	G-002
SHEET 2 OF 51	SHEET 2 OF 51	SHEET 2 OF 51	SHEET 2 OF 51	SHEET 2 OF 51	SHEET 2 OF 51	SHEET 2 OF 51	SHEET 2 OF 51	SHEET 2 OF 51	SHEET 2 OF 51

PROJECT MANAGER: _____	DATE: _____	DEPICTION OF MONUMENTS: _____	DATE: _____	SUBMITTED: _____	DATE: _____	DESIGN: _____	DATE: _____	 COWI <small>1311 13th Street, 19th Floor, Berkeley, CA 94710 Tel: 415.863.8877 Fax: 415.863.8755</small>	BERKELEY MARINA DOCK REPLACEMENT (D-E) CITY OF BERKELEY, ALAMEDA COUNTY, CALIFORNIA SHEET INDEX AND ABBREVIATIONS
SURVEY PARTY CHIEF: _____	DATE: _____	WATERSHED REVIEW: _____	DATE: _____	SUPERVISING CIVIL ENGINEER: _____	DATE: _____	DRAWN: _____	DATE: _____		
CITY ENGINEER: _____	DATE: _____	DATE: _____	DATE: _____	APPROVED: _____	DATE: _____	CHECK: _____	DATE: _____		
FOR REDUCED PLANS - ORIGINAL SCALE IS IN INCHES		DATE: _____		DATE: _____		DATE: _____		DATE: _____	

BASIS OF DESIGN

1. PROJECT DESCRIPTION:

- A. THE CONTRACTOR SHALL PROVIDE THE DESIGN, AS WELL AS ALL LABOR, SUPERVISION, EQUIPMENT, APPLIANCES AND MATERIALS REQUIRED TO PERFORM ALL OPERATIONS IN CONNECTION WITH AT LEAST, BUT NOT NECESSARILY LIMITED TO, THE SUCCESSFUL COMPLETION OF THE FOLLOWING ITEMS, ALL IN STRICT ACCORDANCE WITH THE CONTRACT DOCUMENTS:
- REMOVAL, STORAGE, AND RE-INSTALLATION OF EXISTING FLOATS, GANGWAYS AND RELATED ACCESSORIES
 - REMOVAL AND DISPOSAL OF EXISTING REVETMENT AND SLOPE MATERIAL IN ORDER TO PROPERLY INSTALL NEW WORK
 - INSTALLATION OF NEW GEOTEXTILE FABRIC, BEDDING LAYER, AND REVETMENT SLOPE PROTECTION AT REQUIRED LOCATIONS REPLACEMENT OF ANY DAMAGED UTILITY STRUCTURE DAMAGED DURING THE CONSTRUCTION ACTIVITIES WITH IN-KIND OR BETTER QUALITY.
- B. SHOULD THE CONTRACTOR OR ANY SUBCONTRACTOR FIND ANY DEFICIENCIES, ERRORS, CONFLICTS OR OMISSIONS IN THESE PLANS AND SPECIFICATIONS OR SHOULD THERE BE DOUBT AS TO THEIR MEANING OR INTENT, THE CONTRACTOR SHALL CEASE WORK AND THE ENGINEER SHALL BE NOTIFIED IMMEDIATELY. THE ENGINEER WILL PROVIDE WRITTEN CLARIFICATION.
- C. THE CONTRACTOR SHALL BE RESPONSIBLE FOR THE PROTECTION OF ALL EXISTING SURVEY MONUMENTS AND CONTROL POINTS. ALL MONUMENTS DESTROYED DURING CONSTRUCTION SHALL BE RESURVEYED AND REPLACED BY THE CONTRACTOR AT THE CONTRACTOR'S EXPENSE, AS OUTLINED IN THE BUSINESS AND PROFESSIONS CODE, SECTION 8771.
- D. DIMENSIONS AND EXISTING CONDITIONS DEPICTED ON THE CONTRACT DRAWINGS SHALL BE VERIFIED BY THE CONTRACTOR PRIOR TO COMMENCEMENT OF WORK. ANY DISCREPANCIES SHALL BE NOTED BY THE CONTRACTOR AND REVIEWED WITH THE OWNER PRIOR TO ORDERING, CONSTRUCTION, OR FABRICATION OF CONSTRUCTION MATERIALS.
- E. ALL SECTIONS, DETAILS, NOTES, DIMENSIONS AND CONDITIONS ARE APPLICABLE AT ANY OTHER LOCATION WHERE CONDITIONS AND DETAILS ARE SIMILAR BUT ARE NOT SPECIFICALLY NOTED AS SUCH OR ARE NOT SHOWN.

2. DESIGN CRITERIA:

- A. ALL STRUCTURES SHALL BE DESIGNED IN ACCORDANCE WITH THE FOLLOWING DESIGN CODES AND STANDARDS:
- CALIFORNIA BUILDING CODE, 2019
 - CITY OF BERKELEY STANDARD DETAILS, 2022.
 - "LAYOUT AND DESIGN GUIDELINES FOR MARINA BERTHING FACILITIES," BY CALIFORNIA DEPARTMENT OF BOATING AND WATERWAYS, STATE OF CALIFORNIA, JULY 2005.
 - "PLANNING AND DESIGN GUIDELINES FOR SMALL CRAFT HARBORS," AMERICAN SOCIETY OF CIVIL ENGINEERS, 2020.
 - NATIONAL FIRE PROTECTION ASSOCIATION (NFPA) CODE 303: FIRE PROTECTION STANDARDS FOR MARINAS AND BOATYARDS.
 - AMERICAN SOCIETY OF CIVIL ENGINEERS, "MINIMUM DESIGN LOADS FOR BUILDINGS AND OTHER STRUCTURES," ASCE/SEI 7-22, 2022.
 - AMERICAN WITH DISABILITY ACT "ADA STANDARDS FOR ACCESSIBLE DESIGN" AND "GUIDANCE ON ADA STANDARDS FOR ACCESSIBLE DESIGN", 2010.
 - AMERICAN INSTITUTE OF STEEL CONSTRUCTION "SR=TEEL CONSTRUCTION MANUAL" AISC 325-17, 15TH EDITION
- B. STRUCTURES SHALL BE DESIGNED ACCORDING TO THE FOLLOWING DESIGN CRITERIA:
- LIVE LOADS
- 400 LB CONCENTRATED LOAD ON ANY 1 SF AREA (FLOATING DOCK)
 - 25 PSF UNIFORM LIVE LOAD (FLOATING DOCK)
 - 100 PSF UNIFORM LIVE LOAD (FIXED PLATFORMS)
- SEE GANGWAY AND ACCESS RAMPS SECTION FOR LOADING
- THE PRIMARY GLOBAL LOADS USED FOR DESIGN OF THE MARINE STRUCTURES SHALL CONSIST OF RATIONAL COMBINATIONS OF WIND, CURRENT, AND WAVES.
- THE CONTRACTOR SHALL BE RESPONSIBLE FOR ENGAGING A QUALIFIED PROFESSIONAL ENGINEER, REGISTERED IN THE STATE OF CALIFORNIA, TO PERFORM HYDRODYNAMIC ANALYSIS TO COMPUTE THE ENVIRONMENTAL GLOBAL LOADS & MOTION BEHAVIOR.
- WIND LOADS
- EXPOSURE D

85 MPH MAXIMUM WIND VELOCITY
 HYDRODYNAMIC LOADS
 TIDES: SEE DWG G-005 FOR MLLW ELEVATIONS
 CURRENT: 1.8 KNOTS (2 FT/SEC)

3. GEOTECHNICAL INVESTIGATION:

A. GEOTECHNICAL INVESTIGATION BERKELEY MARINA REHABILITATION, DECEMBER 16, 2004 BY TREADWELL&ROLLO

4. SOIL AND SEISMIC:

2019 CALIFORNIA BUILDING CODE SEISMIC DESIGN PARAMETERS

A. SEISMIC CATEGORY: D
 B. SITE CLASS: E
 C. MAP SPECTRAL RESPONSE: $S_s = 1.774$ g, $S_1 = 0.674$ g
 D. MAPPED PEAK GROUND ACCELERATION: $PGA = 0.746$ g
 E. SITE CLASS E MODIFICATION FACTORS
 $F = 1.2$
 $F = 2.0$
 $F_{PGA} = 1.1$
 F. SITE-MODIFIED SPECTRAL RESPONSE:
 $S_{MS} = 2.129$ g (SITE CLASS E)
 $S_{M1} = 1.348$ g (SITE CLASS E)
 G. SITE-MODIFIED PEAK GROUND ACCELERATION:
 $PGA_M = 0.821$ g (SITE CLASS E)

5. RETAINING WALL:

A. DESIGN EQUIVALENT FLUID PRESSURE = 45 PCF
 B. DESIGN LATERAL RESISTANCE = 400 PCF

6. DOCK GUIDE PILING:

A. AXIAL LOAD = N/A
 B. LATERAL LOAD AT PILE HEAD = 1.4K MAXIMUM
 C. EFFECTIVE PRESTRESS MINIMUM = 1,055 PSI AFTER LOSSES
 D. PILE STICKUP MAXIMUM = 25'
 E. PILE EMBEDMENT MINIMUM = 35'
 F. PILE LENGTH MINIMUM = 63'
 G. PILE CROSS SECTION = 18" OCTAGONAL
 H. CONCRETE STRENGTH MINIMUM FC = 6,500 AT 28 DAYS

7. FLOATING DOCKS:

A. SUPPORT A LIVE LOAD OF TWENTY FIVE (25) POUNDS PER SQUARE FOOT OF DECK AREA WITH A FREEBOARD OF NOT LESS THAN TWELVE (12) INCHES.

B. THE DECK STRUCTURE SHALL HAVE SUFFICIENT FLOATION TO SUPPORT ALL TRANSMITTED LOADS.

C. THE DECK STRUCTURE SHALL HAVE SUFFICIENT FLOATION TO SUPPORT THE TRANSMITTED DEAD LOAD AND LIVE LOAD FROM THE GANGWAY.

D. THE GANGWAY LIVE LOAD SHALL BE CALCULATED ON A BASIS OF 100 POUNDS PER SQUARE FOOT LIVE LOAD APPLIED TO THE TOTAL SURFACE AREA OF THE GANGWAY.

E. THE FREEBOARD UNDER THESE IMPOSED LOADS SHALL NOT BE LESS THAN TWELVE (12) INCHES AND SHALL MEET THE TRANSVERSE AND LONGITUDINAL SLOPES SET FORTH BELOW:

- DEAD LOAD ONLY, AND DEAD LOAD + UNIFORM LIVE LOAD:
 - MAXIMUM CROSS SLOPE 1/4 INCH PER FOOT, NOT TO EXCEED ONE INCH MAXIMUM.
 - MAXIMUM LONGITUDINAL SLOPE 1/8 INCH PER FOOT, NOT TO EXCEED ONE INCH IN 10 FEET.
- DEAD LOAD + LIVE POINT LOAD:
 - MAXIMUM CROSS SLOPE 1/2 INCH PER FOOT (4%), NOT TO EXCEED TWO INCHES MAXIMUM.
 - MAXIMUM LONGITUDINAL SLOPE 1/4 INCH PER FOOT, NOT TO EXCEED TWO INCHES IN 10 FEET.

- A. FREEBOARD UNDER DEAD LOAD ONLY SHALL NOT BE LESS THAN FIFTEEN (15) INCHES OR EXCEED EIGHTEEN (18) INCHES.
- B. THE FLOATION UNITS SHALL BE CAPABLE OF SUPPORTING A MINIMUM 400 POUND LIVE POINT LOAD APPLIED AT ANY POINT ON THE DECK, NOT CLOSER THAN 12" FROM ANY EDGE, WITHOUT PROVIDING LESS THAN THE MINIMUM SPECIFIED FREEBOARD OR SLOPES.
- C. THE DOCK UNITS SHALL BE CAPABLE OF WITHSTANDING AN ANTICIPATED CURRENT LOADS OF 2 FPS, IMPACT LOADS FROM A 60 TON VESSEL IMPACTING AT 1FT/SEC APPROACH VELOCITY (A 1/3 STRESS INCREASE IS ALLOWED SINCE THE FORCE IS TRANSIENT), AND A 1.0 FOOT WAVE ENVIRONMENT AND 2.0 FOOT POTENTIAL BOAT WAKE (A 1/3 STRESS INCREASE IS ALLOWED SINCE THE FORCE IS TRANSIENT).
- D. DEAD LOADS SHALL CONSIST OF THE FLOATS, FRAMING, DECKING CONNECTIONS, AND ALL PERMANENTLY ATTACHED EQUIPMENT. THE WEIGHT OF LUMBER FOR THESE CALCULATIONS SHALL BE ASSUMED AT NO LESS THAN FORTY POUNDS PER CUBIC FOOT.
- E. WIND LOADS FOR FINGER FLOATS SHALL BE A UNIFORMLY DISTRIBUTED LOAD OF FIFTEEN (15) POUNDS PER SQUARE FOOT ACTING ON THE ABOVE WATER PROFILE OF POTENTIAL BERTHED CRAFT. THE BOAT PROFILE AREA SHALL BE DETERMINED BY USING THE LENGTH AND AN AVERAGE PROFILE HEIGHT EQUAL TO FIFTEEN PERCENT (15%) OF THE BOAT LENGTH.

8. GENERAL:

- A. UNLESS NOTED OTHERWISE, REFER TO DRAWINGS OTHER THAN STRUCTURAL FOR FINISHES, SLOPES, DEPRESSIONS, OPENINGS, CURBS, STAIRS, RAMPS, TRENCHES, EQUIPMENT AND LOCATIONS AND EXTENT OF SUCH CONDITIONS.
- B. INSTALLATION OF ALL NEW IN-WATER STRUCTURES SHALL BE IN ACCORDANCE WITH ALL ENVIRONMENTAL PERMIT CONDITIONS. CONTRACTOR SHALL SUBMIT PILE DRIVING PROCEDURES AND PROTECTION PLAN TO THE OWNER'S REPRESENTATIVE PRIOR TO BEGINNING IN-WATER WORK. CONTRACTOR SHALL SUBMIT COMPLIANCE PLAN FOR MITIGATION MEASURE(S) ABOVE PRIOR TO PILE DRIVING.
- C. CONTRACTOR SHALL USE NOISE-REDUCING PILE DRIVING TECHNIQUES SUCH AS VIBRATING PILES INTO PLACE, WHERE FEASIBLE, AND RESTRICTING THE HOURS OF OPERATION.
- D. PILE DRIVING OR OTHER EXTREME NOISE GENERATING ACTIVITY (80 DBA AT A DISTANCE OF 100 FEET) SHALL BE LIMITED TO 8:00 AM TO 5:00 PM, MONDAY THROUGH FRIDAY AND AS RESTRICTED TO PERIOD AND TIMES TO BE NOTED IN PERMITS. NO PILE DRIVING OR OTHER EXTREME NOISE GENERATING ACTIVITY IS PERMITTED ON SATURDAYS, SUNDAYS OR HOLIDAYS. REQUESTS FOR PILE DRIVING ON SATURDAYS MAY BE CONSIDERED ON A CASE BY CASE BASIS BY THE CITY OF BERKELEY.

9. GEO-TEXTILE FABRIC MATERIAL:

- A. THE GEO-TEXTILE FABRIC IS DESIGNED TO ACT AS A FILTER FOR THE FOUNDATION OF THE REVETMENT STRUCTURE.
- B. THE GEO-TEXTILE FABRIC IS SIZED TO RETAIN THE SILTY/SANDY SEDIMENT AND PREVENT MIGRATION AND PIPING THROUGH THE VOIDS OF THE RUBBLE WHEN SUBJECTED TO INUNDATION BY BREAKING WAVES AND GROUND SEEPAGE.
- C. THE GEO-TEXTILE FABRIC MATERIAL SHALL BE A NON-WOVEN POLYPROPYLENE GEO-TEXTILE MEETING AASHTO M288-96 SPECIFICATIONS, SUCH AS MIRAFI 1100N OR EQUIVALENT.
- D. THE GEO-TEXTILE FABRIC SHALL BE INERT TO BIOLOGICAL DEGRADATION AND RESISTANT TO NATURALLY ENCOUNTERED CHEMICALS, ACIDS, AND ALKALIS.

10. CONCRETE:

- A. CONCRETE WORK SHALL CONFORM TO ALL REQUIREMENTS OF SPECIFICATIONS SECTION 03330 - CAST-IN-PLACE.
- B. ALL CONCRETE SHALL BE NORMAL WEIGHT, WITH A MINIMUM 28 DAY COMPRESSIVE STRENGTH OF: 4000 PSI
- C. CONCRETE REINFORCING COVER SHALL BE AS FOLLOWS:
 - RETAINING WALL: 3 INCHES

- FOOTINGS AND SLABS CAST AGAINST OR EXPOSED TO EARTH: 3 INCHES
 - CONCRETE EXPOSED TO WEATHER: 2 INCHES
- D. ALL CONCRETE DIMENSIONS SHOWN ARE MINIMUM DIMENSIONS. CONTRACTOR SHALL REVIEW FORMING, REINFORCING DETAILS AND ANY EMBEDDED ITEMS AND DETERMINE THE PLACEMENT REQUIREMENTS AND CLEARANCES PRIOR TO FABRICATION OF ANY REINFORCING.

11. REINFORCING STEEL:

- A. ALL CONCRETE REINFORCING SHALL BE:
 - ASTM A 615, GRADE 60
 - ASTM A 706, GRADE 60
 - EPOXY COATED PER ASTM A775, UNO
- B. NO WELDING OF ANY REINFORCING SHALL BE PERMITTED.

12. LUMBER:

- A. ALL LUMBER SHALL BE PRESSURE TREATED (PT) PER PROJECT SPECIFICATIONS - 06130.
- B. ALL MEMBERS ARE TO BE DOUGLAS FIR LARCH, S4S, WITH A MINIMUM ALLOWABLE FLEXURAL STRESS RATING OF 1300 PSI.
- C. GRADING REQUIREMENTS ARE AS FOLLOWS:
 - 3X DECKING (MIN.): #1, KDAT-19
 - 2X WALES: #1, KDAT-19
- D. ALL DECKING SCREWS SHALL BE COUNTERSUNK IN DECKING WALERS AND RUB STRIPS.
- E. ALL CONNECTOR BOLTS SHALL BE HOT-DIP GALVANIZED AND CONFORM TO ASTM A307.
- F. BOLT SPACING, EDGE AND END DISTANCES IN WOOD MEMBERS SHALL CONFORM WITH CBC REQUIREMENTS.
- G. ALL BOLTS AND LAG SCREWS SHALL BE PROVIDED WITH STANDARD CUT STEEL WASHERS UNDER HEADS AND NUTS BEARING ON WOOD.
- H. ALL BOLTS OR STEEL HARDWARE EXPOSED TO MOISTURE SHALL BE HOT-DIP GALVANIZED.
- I. ALL NAILS AND FASTENERS DRIVEN INTO PRESSURE-TREATED LUMBER SHALL BE HOT-DIP GALVANIZED.
- J. DECKING SCREWS SHALL BE A316 STAINLESS STEEL.
- K. BRUSH CUT TREATED LUMBER SURFACES WITH COPPER NAPHTHENATE PRIOR TO INSTALLATION.

13. STRUCTURAL STEEL:

- A. HOT-DIP GALVANIZE ALL STEEL ELEMENTS AFTER FABRICATION AND WELDING UNLESS OTHERWISE NOTED.
- B. ALL EXPOSED NON-GALVANIZED STEEL SURFACES AND FASTENERS SHALL BE COATED PER SPECIFICATIONS UNLESS OTHERWISE NOTED.

14. FLOATING DOCKS

- A. REINFORCEMENT SHALL BE EPOXY-COATED PER REINFORCING SECTION. SEE SPECIFICATIONS.
- B. WIRE MESH TO BE GALVANIZED, SEE SPECIFICATIONS.
- C. DIMENSIONS SHOWN ARE TYPICAL FOR ALL FLOATS UNO.
- D. WIDTH DIMENSIONS SHOWN ARE NOMINAL. CONTRACTOR MAY VARY WIDTH WITHIN SPECIFIED TOLERANCES TO SUIT MANUFACTURER'S PROPRIETARY FORMWORK.

PLOTTED BY: NIEL FORTEZ PLOT DATE: 05/10/2023 11:08:56 AM

DRAFT 90% Submittal

REV	DATE	DESCRIPTION	APPROVAL
C	05-12-2023	90% PROGRESS SUBMITTAL	JMC
B	03-27-2023	60% PROGRESS SUBMITTAL	JMC
A	06-03-2022	30% PROGRESS SUBMITTAL	JMC

PROJECT MANAGER: _____	DATE: _____	DEPICTION OF MONUMENTS: _____	DATE: _____	SUBMITTED: _____	DATE: _____	DESIGN: _____	HORIZ.: _____
SURVEY PARTY CHIEF: _____		DATE: _____		SUPERVISING CIVIL ENGINEER: _____		DRAWN: _____	
WATERSHED REVIEW: _____		DATE: _____		APPROVED: _____		CHECK: _____	
DATE: _____		DATE: _____		R.C.E.: _____		BOOK: _____	
DATE: _____		DATE: _____		EXP.: _____		DATE: 6/3/22	
AS BUILT: _____		DATE: _____		DATE: 6/3/22		DATE: _____	

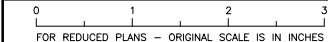

FOR REDUCED PLANS - ORIGINAL SCALE IS IN INCHES



COWI
 CONSULTING ENGINEERS
 1101 BAY STREET, 17TH FLOOR, OAKLAND, CA 94612
 TEL: 510.898.8072 FAX: 510.898.8175

BERKELEY MARINA DOCK REPLACEMENT (D-E)
 CITY OF BERKELEY, ALAMEDA COUNTY, CALIFORNIA

BASIS OF DESIGN AND SPECIAL INSPECTION - 1 of 2

PLAN _____

FILE _____

G-003

SHEET 3 OF 51

BASIS OF DESIGN

14. FLOATING DOCKS CONT.
- E. CONTRACTOR SHALL BE RESPONSIBLE TO DETERMINE DEPTH DIMENSION "D" FOR ALL FLOATS AND DIMENSION "W" FOR ONE FLOAT SUPPORTING THE RAMP AND GANGWAY. SUFFICIENT DEPTH "D" SHALL BE PROVIDED TO SUPPORT THE DOCK SYSTEM DEAD LOAD INCLUDING UTILITIES AND ALL DOCK ACCESSORIES AT THE REQUIRED FREEBOARD. SEE SPECIFICATIONS.
- F. FOR MINIMUM NUMBER OF RACEWAYS REQUIRED, SEE SPECIFICATIONS. FOR RACEWAY ALLOCATION AND JUNCTION BOX REQUIREMENTS, SEE ELECTRICAL SHEETS.
- G. ALL THROUGH RODS, BOLTING AND MISCELLANEOUS STEEL ITEMS SHALL BE HOT-DIP GALVANIZED.
- H. TIMBER FOR WALERS AND RUBSTRIPS SHALL BE PRESSURE TREATED FOR SALT WATER EXPOSURE OR APPROVED EQUAL. SEE SPECIFICATIONS.
15. GANGWAYS AND ACCESS RAMPS:
- A. GANGWAYS AND RAMPS SHALL BE DESIGNED FOR A VERTICAL LIVE LOAD OF 100 PSF IN ADDITION TO ALL OTHER CODE PRESCRIBED LOAD CONDITIONS.
- B. MAXIMUM DEFLECTION FOR RAMP AND GANGWAY SPAN SHALL NOT EXCEED LSPAN/360.
16. ADA REQUIREMENTS:
- A. THE MAXIMUM CROSS SLOPE SPECIFIED FOR GANGWAY, TRANSITION PLATES, AND FLOATING PIERS THAT ARE PART OF THE ADA ACCESSIBLE ROUTES SHALL NOT EXCEED 2%, MEASURED IN THE STATIC POSITION.

CBC COMPLIANCE

- A. THE CONTRACTOR SHALL COMPLY WITH THE FOLLOWING REQUIREMENTS OF THE 2019 CBC:

1706.1 CONTRACTOR RESPONSIBILITY.

- B. EACH CONTRACTOR RESPONSIBLE FOR THE CONSTRUCTION OF A MAIN WIND-OR SEISMIC-FORCE-RESISTING SYSTEM, DESIGNATED SEISMIC SYSTEM OR A WIND- OR SEISMIC-RESISTING COMPONENT LISTED IN THE STATEMENT OF SPECIAL INSPECTIONS SHALL SUBMIT A WRITTEN STATEMENT OF RESPONSIBILITY TO THE BUILDING OFFICIAL AND THE OWNER PRIOR TO THE COMMENCEMENT OF WORK ON THE SYSTEM OR COMPONENT. THE CONTRACTOR'S STATEMENT OF RESPONSIBILITY SHALL CONTAIN THE FOLLOWING:
1. ACKNOWLEDGEMENT OF AWARENESS OF THE SPECIAL REQUIREMENTS CONTAINED IN THE STATEMENT OF SPECIAL INSPECTIONS;
 2. ACKNOWLEDGEMENT THAT CONTROL WILL BE EXERCISED TO OBTAIN CONFORMANCE WITH THE CONSTRUCTION DOCUMENTS APPROVED BY THE BUILDING OFFICIAL;
 3. PROCEDURES FOR EXERCISING CONTROL WITHIN THE CONTRACTOR'S ORGANIZATION, THE METHOD AND FREQUENCY OF THAT REPORTING AND THE DISTRIBUTION OF THE REPORTS; AND
 4. IDENTIFICATION AND QUALIFICATIONS OF THE PERSON(S) EXERCISING SUCH CONTROL AND THEIR POSITION(S) IN THE ORGANIZATION.

SPECIAL INSPECTION REQUIREMENTS

- A. SPECIAL INSPECTIONS SHALL MEET THE REQUIREMENTS OF CBC SECTION 1701.
- B. SPECIAL INSPECTORS SHALL:
1. BE UNDER THE SUPERVISION OF A REGISTERED CIVIL ENGINEER.
 2. OBSERVE THE WORK ASSIGNED FOR CONFORMANCE WITH APPROVED DRAWINGS.
 3. FURNISH INSPECTION REPORTS TO THE ENGINEER. DISCREPANCIES SHALL BE BROUGHT TO THE IMMEDIATE ATTENTION OF THE CONTRACTOR FOR CORRECTION; THEN, IF NOT CORRECTED, TO THE ENGINEER AND CITY.
 4. SUBMIT TO THE ENGINEER AND CITY A FINAL REPORT, SIGNED BY A REGISTERED CIVIL ENGINEER, STATING THAT THE WORK WAS IN CONFORMANCE WITH THE APPROVED DRAWINGS AND THE APPLICABLE WORKMANSHIP PROVISIONS OF THE 2019 CBC.
- C. INSPECTION NOTES:
1. SPECIAL INSPECTORS MUST BE CERTIFIED BY THE CITY OR ICBO/ICC TO PERFORM THE TYPES OF INSPECTION SPECIFIED.
 2. IT IS THE RESPONSIBILITY OF THE CONTRACTOR TO INFORM THE SPECIAL INSPECTOR OR INSPECTION AGENCY AT LEAST ONE WORKING DAY BEFORE PERFORMING ANY WORK THAT REQUIRES SPECIAL INSPECTION. ALL WORK PERFORMED WITHOUT REQUIRED SPECIAL INSPECTION IS SUBJECT TO REMOVAL.

REQUIRED VERIFICATION AND INSPECTION OF SOILS & PIER FOUNDATIONS		
VERIFICATION AND INSPECTION TASK	CONTINUOUS DURING TASK LISTED	PERIODICALLY DURING TASK LISTED
VERIFY MATERIALS BELOW FOOTINGS ARE ADEQUATE TO ACHIEVE THE DESIGN BEARING CAPACITY	---	X
VERIFY EXCAVATIONS ARE EXTENDED TO PROPER DEPTH AND HAVE REACHED PROPER MATERIAL.	---	X

REQUIRED VERIFICATION AND INSPECTION OF CONCRETE CONSTRUCTION				
VERIFICATION AND INSPECTION TASK	CONTINUOUS	PERIODIC	REFERNCED STANDARD	CBC REFERENCE
INSPECTION OF REINFORCING STEEL, AND PLACEMENT	---	X	CH 20, 25.2, 25.3, 26.5.1-26.5.3, 26.5	1908.4, 1910A.2-1910A.3
VERIFY USE OF REQUIRED DESIGN MIX	---	X	ACI 318: Ch.19, 26.2-26.4	1904.1, 1904.2, 1908.2, 1908.3
AT THE TIME FRESH CONCRETE IS SAMPLED TO FABRICATE SPECIMENS FOR STRENGTH TESTS, PERFORM SLUMP AND AIR CONTENT TESTS, AND DETERMINE THE TEMPERATURE OF THE CONCRETE	X	---	ASTM C 172 ASTM C 31 ACI 318: 26.5	1908.10, 1903A
INSPECTION OF CONCRETE PLACEMENT FOR PROPER APPLICATION TECHNIQUES	X	---	ACI 318: 26.5	1908.6, 1908.7, 1908.8
INSPECTION FOR MAINTENANCE OF SPECIFIED CURING TEMPERATURE AND TECHNIQUES	---	X	ACI 318: 26.5, 26.6.2	1904A
INSPECT FORMWORK FOR SHAPE, LOCATION AND DIMENSIONS OF THE CONCRETE MEMBER BEING FORMED	---	X	ACI 318: 26.1	---
INSPECTION OF PRESTRESSED CONCRETE: A. APPLICATION OF PRESTRESSING FORCES	X	---	ACI 318: 26.10	---

APPROVAL	JMC
DESCRIPTION	80% PROGRESS SUBMITTAL
DATE	05-12-2023
MARK	A
REVISION	A

PROJECT MANAGER: _____ DATE _____	DEPICTION OF MONUMENTS: _____ DATE _____	SUBMITTED: _____ DATE _____	DESIGN: <u>JRVS</u>	HORIZ. _____	 BERKELEY <small>PHONIC RECREATION & WATERFRONT 1847 CENTER ST., 9TH FL., BERKELEY, CA 94704</small>	 COWI <small>1111 15th Street, 15th Floor, Oakland, CA 94612 Tel: 510.888.8872 Fax: 510.888.8752</small>	BERKELEY MARINA DOCK REPLACEMENT (D-E) CITY OF BERKELEY, ALAMEDA COUNTY, CALIFORNIA BASIS OF DESIGN AND SPECIAL INSPECTION - 2 OF 2	PLAN _____
SURVEY PARTY CHIEF _____	WATERSHED REVIEW: _____ DATE _____	SUPERVISING CIVIL ENGINEER _____	DRAWN: <u>NIF</u>	VERT. _____				FILE _____
APPROVED: _____	DATE _____	CITY ENGINEER _____	CHECK: <u>JMC</u>	BOOK _____				G-004
 FOR REDUCED PLANS - ORIGINAL SCALE IS IN INCHES		DATE: <u>6/3/22</u> AS BUILT _____	DATE: <u>6/3/22</u>	SHEET 4 OF 51				

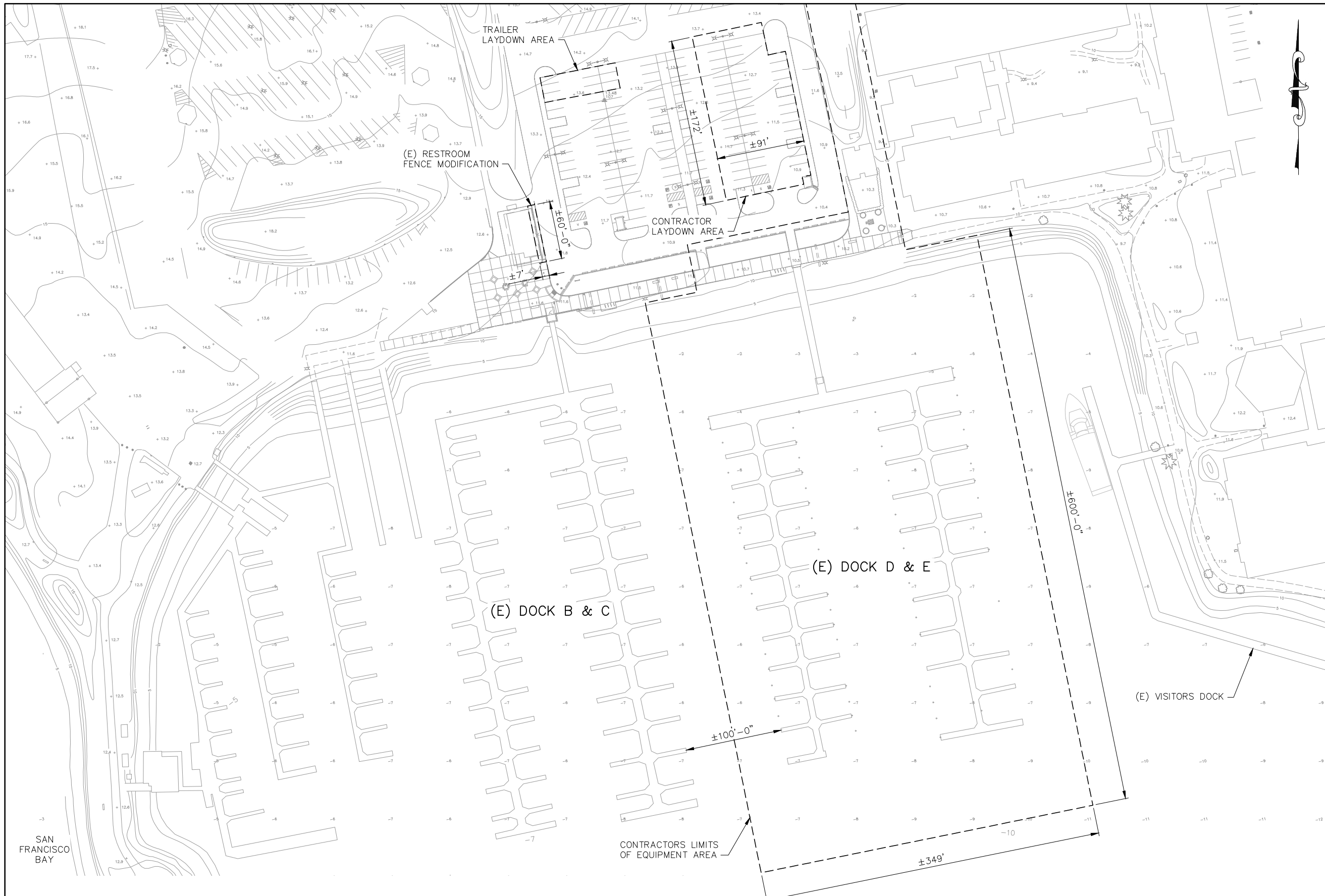

- NOTES:**
1. COORDINATE LAYDOWN AREA WITH CITY PROJECT MANAGER.
 2. CONTRACTOR TO PROTECT IN PLACE ALL ELEMENTS NOT BEING DEMOLISHED.
 3. ALL EQUIPMENT TO BE STORED AND ANCHORED WITHIN BOUNDARY LIMITS AND CONTRACTOR LAYDOWN AREA.

DRAFT 90% Submittal

REVISION	MARK	DATE	DESCRIPTION	APPROVAL
C		05-12-2023	50% PROGRESS SUBMITTAL	JMC
B		03-27-2023	60% PROGRESS SUBMITTAL	JMC
A		06-03-2022	30% PROGRESS SUBMITTAL	JMC

SITE PLAN — PROJECT LIMITS AND CONTRACTOR LAYDOWN AREA 1
 SCALE: 1" = 50'-0"

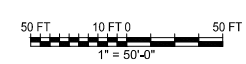

PROJECT MANAGER: _____ DATE _____	DEPICTION OF MONUMENTS: _____ DATE _____	SUBMITTED: _____ DATE _____	DESIGN: <u>JRVS</u> HORIZ. <u>AS SHOWN</u>	 COWI <small>1315 BAY STREET, 15TH FLOOR, BERKELEY, CA 94704</small> <small>TEL: 510.868.8972 FAX: 510.868.9755</small>	BERKELEY MARINA DOCK REPLACEMENT (D-E)	PLAN _____
SURVEY PARTY CHIEF _____	WATERSHED REVIEW: _____ DATE _____	SUPERVISING CIVIL ENGINEER _____	DRAWN: <u>NIF</u> VERT. _____		CITY OF BERKELEY, ALAMEDA COUNTY, CALIFORNIA	FILE _____
APPROVED: _____	CITY ENGINEER _____	AS BUILT _____	CHECK: <u>JMC</u> BOOK _____		PROJECT LIMITS AND CONTRACTOR LAYDOWN AREA	G-005
			DATE: <u>6/3/22</u>			SHEET 5 OF 51

PLOTTED BY: NUEL FORREZ PLOT DATE: 05/19/2023 11:15:01 AM

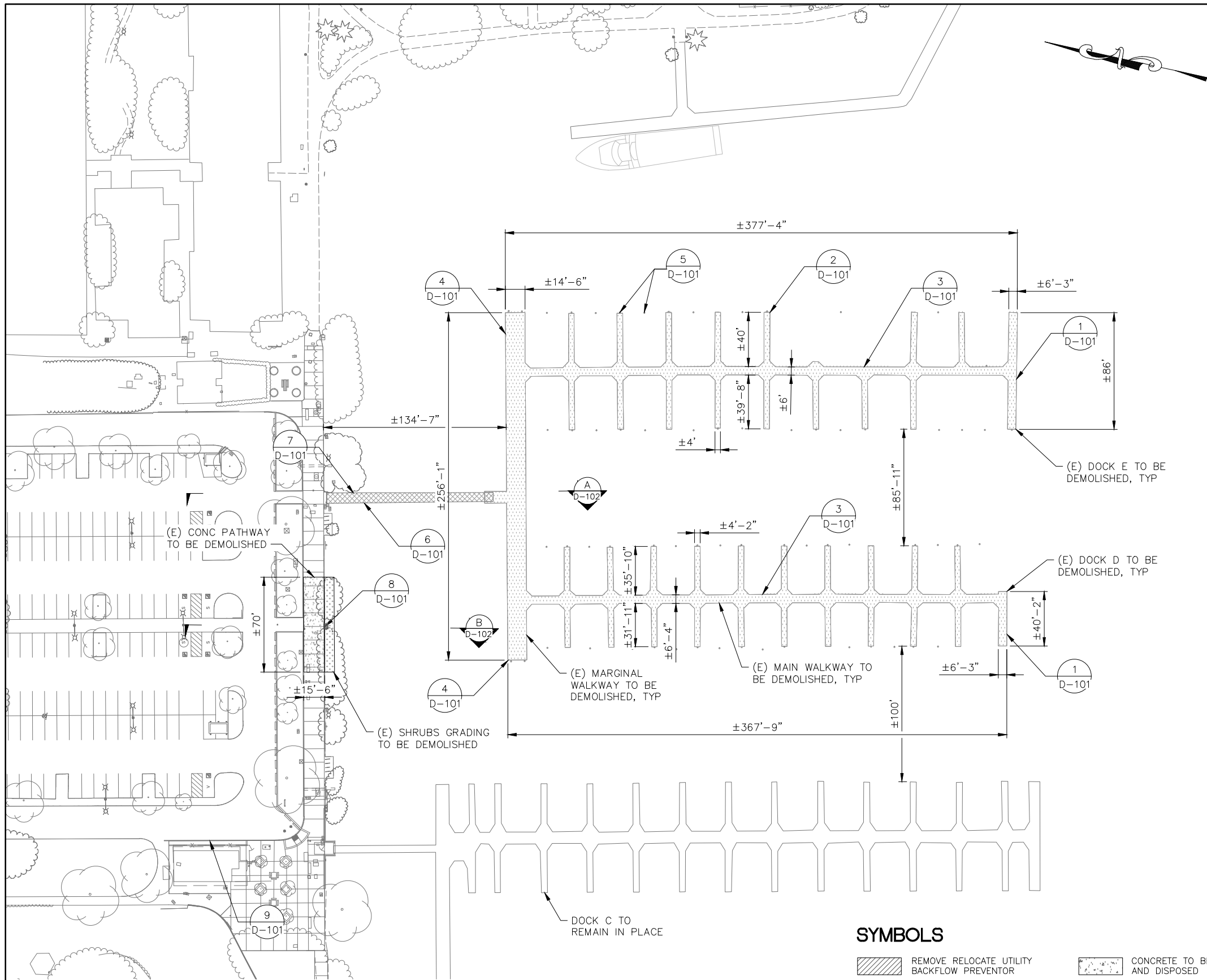

NOTES:

- CONTRACTOR TO COORDINATE WITH CITY REPRESENTATIVE PRIOR TO DEMOLITION OF UTILITIES AND CONTROLS. REUSE & RELOCATE IRRIGATION CONTROLLERS AS DIRECTED BY THE CITY. MAINTAIN OPERATION OF CONTROLS FOR LANDSCAPING DURING CONSTRUCTION.
- CONTRACTOR TO INVESTIGATE AND REPORT TO CITY LOCATIONS AT DOUBLE AND END TIE BERTHS WHERE PILES ARE MISSING OR BROKEN BELOW WATER. REMOVE & DISPOSE OF PILE STUBS EXTENDING ABOVE THE MUDLINE.
- SIDEWALK DEMOLITION SHALL TERMINATE AT EXISTING JOINTS. REPAIR ANY DAMAGE TO IMPROVEMENTS TO REMAIN AT NO ADDITIONAL COST.
- SAWCUT PAVEMENT AT INTERFACE BETWEEN AREAS TO BE REMOVED & AREAS TO REMAIN.
- CONTRACTOR TO VERIFY UTILITIES SERVED THROUGH EXISTING PANELS & BOXES. CONTINUE SERVICE TO UTILITIES OUTSIDE THE SCOPE OF THIS PROJECT, LEAVE ASSOCIATED BOXES IN PLACE UNLESS SERVICE IS TO BE RELOCATED. REMOVE & DISPOSE OF BOXES & PANELS THAT NO LONGER SERVE UTILITIES AFTER DEMOLITION OF DOCKS.
- CONFIRM WATER VALVE LOCATIONS FOR DOCKS AND RELOCATE TO ADJOIN NEW GANGWAY LOCATIONS.
- EXISTING CONDUITS TO BE ABANDONED IN PLACE SHALL BE FILLED WITH GROUT.
- ALL PILES WITHIN THE BERTH AREAS NOTED TO BE REMOVED SHALL BE REMOVED IN THEIR ENTIRETY. PILES BROKEN DURING REMOVAL SHALL BE COMPLETELY REMOVED. STUBS ARE NOT ACCEPTABLE.

LEGEND

- REMOVE AND DISPOSE OF (E) END FLOATS
- REMOVE AND DISPOSE (E) TYPICAL FLOATS
- REMOVE AND DISPOSE (E) MAIN FLOATS
- REMOVE AND DISPOSE (E) MARGINAL FLOATS
- REMOVE AND DISPOSE (E) 16"Ø TIMBER PILES
- REMOVE AND DISPOSE (E) GANGWAY AND GATE
- REMOVE AND DISPOSE (E) TIMBER PIER
- REMOVE AND RELOCATE (E) BACKFLOW PREVENTER. SEE P101 FOR ADDITIONAL INFORMATION
- REMOVE AND RELOCATE (E) RESTROOM EAST SIDE GATE. SEE C-105 FOR ADDITIONAL INFORMATION.

SYMBOLS

- REMOVE RELOCATE UTILITY BACKFLOW PREVENTOR
- REMOVE AND DISPOSE (E) GANGWAY AND PIER
- AC TO BE PULVERIZED AND BLENDED INTO TOP 8"
- CONCRETE TO BE REMOVED AND DISPOSED
- WOOD DOCKS TO BE REMOVED AND DISPOSED
- REMOVE AND STOCKPILE (E) ROCK, WHERE NEEDED, AND CLEAR AND GRUB.

DEMOLITION PLAN
SCALE: 1" = 40'-0"

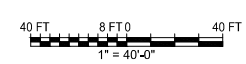

PROJECT MANAGER: _____ DATE _____	DEPICTION OF MONUMENTS: _____ DATE _____	SUBMITTED: _____ DATE _____	DESIGN: <u>JRVS</u>	HORIZ.: <u>AS SHOWN</u>	 COWI 1515 SHILB ROAD, 15TH FLOOR, BERKELEY, CA 94702 TEL: 510.838.8972 FAX: 510.838.9755 WWW.COWI.COM	BERKELEY MARINA DOCK REPLACEMENT (D-E) CITY OF BERKELEY, ALAMEDA COUNTY, CALIFORNIA	PLAN _____
SURVEY PARTY CHIEF _____ DATE _____	WATERSHED REVIEW: _____ DATE _____	SUPERVISING CIVIL ENGINEER _____ DATE _____	DRAWN: <u>NIF</u>	VERT.: _____		DEMOLITION SHEET 1 OF 2	FILE _____
CITY ENGINEER _____ DATE _____		APPROVED: _____ DATE _____	CHECK: <u>JMC</u>	BOOK _____			REVISION _____
FOR REDUCED PLANS - ORIGINAL SCALE IS IN INCHES			DATE: <u>6/3/22</u>	DATE: <u>6/3/22</u>	DATE: _____		APPROVAL _____

DRAFT 90% Submittal

PLOTTED BY: NIEL FORTEZ PLOT DATE: 5/19/2023 11:06:39 AM

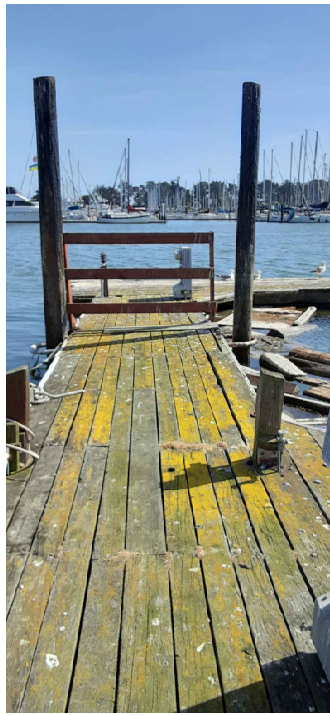

END FLOAT 
D-100/D-101

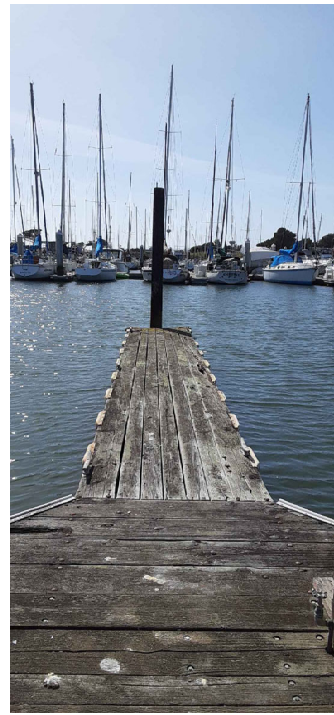

TYPICAL FINGER FLOAT 
D-100/D-101

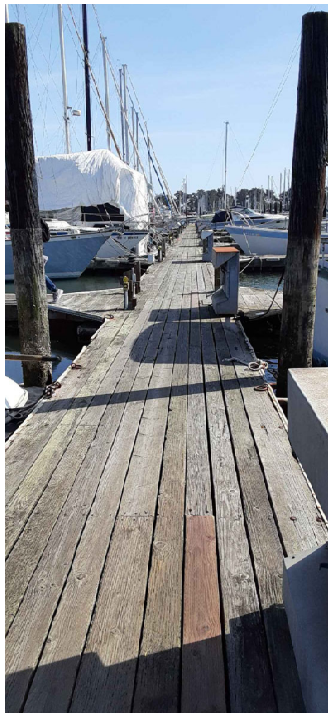

MAIN FLOAT 
D-100/D-101

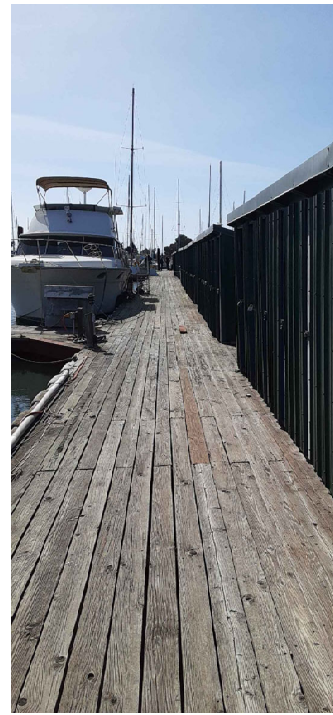

MARGINAL FLOAT 
D-100/D-101



TIMBER PILES 
D-100/D-101

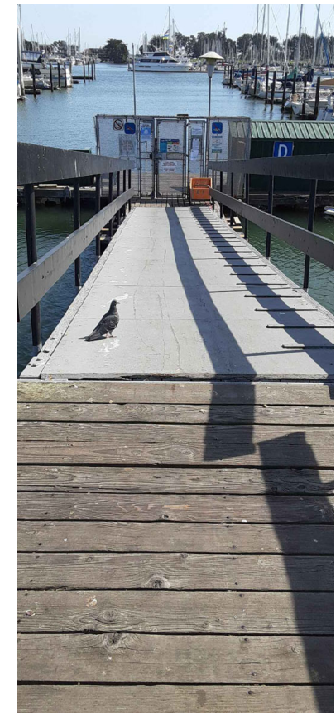

GANGWAY AND GATE 
D-100/D-101

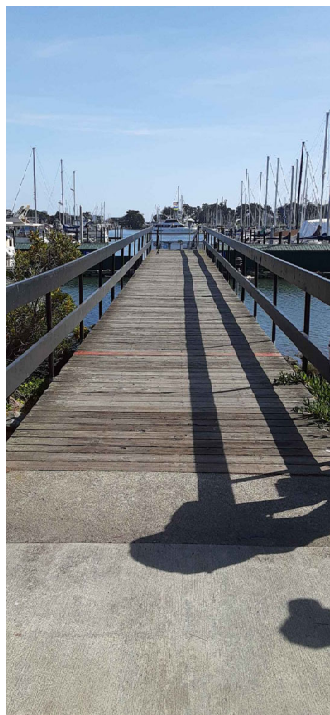

TIMBER PIER 
D-100/D-101



BACKFLOW PREVENTER 
D-100/D-101



RESTROOM FENCE 
D-100/D-101

DRAFT 90% Submittal

REVISION	MARK	DATE	DESCRIPTION	APPROVAL
C		05-12-2023	50% PROGRESS SUBMITTAL	JMC
B		03-27-2023	60% PROGRESS SUBMITTAL	JMC
A		08-03-2022	30% PROGRESS SUBMITTAL	JMC

PROJECT MANAGER: _____ DATE _____	DEPICTION OF MONUMENTS: _____ DATE _____	SUBMITTED: _____ DATE _____	DESIGN: <u>JRVS</u>	HORIZ. <u>NTS</u>	 COWI <small>1311 13th Street, 14th Floor, Berkeley, CA 94712</small> <small>Tel: 510.869.8972 Fax: 510.869.9752</small>	BERKELEY MARINA DOCK REPLACEMENT (D-E) CITY OF BERKELEY, ALAMEDA COUNTY, CALIFORNIA DEMOLITION SHEET 2 OF 2	PLAN _____
FOR REDUCED PLANS - ORIGINAL SCALE IS IN INCHES	WATERSHED REVIEW: _____ DATE _____	APPROVED: _____ DATE _____	DRAWN: <u>NIF</u>	VERT. <u>NTS</u>			FILE _____
		CITY ENGINEER _____	CHECK: <u>JMC</u>	BOOK _____			D-101

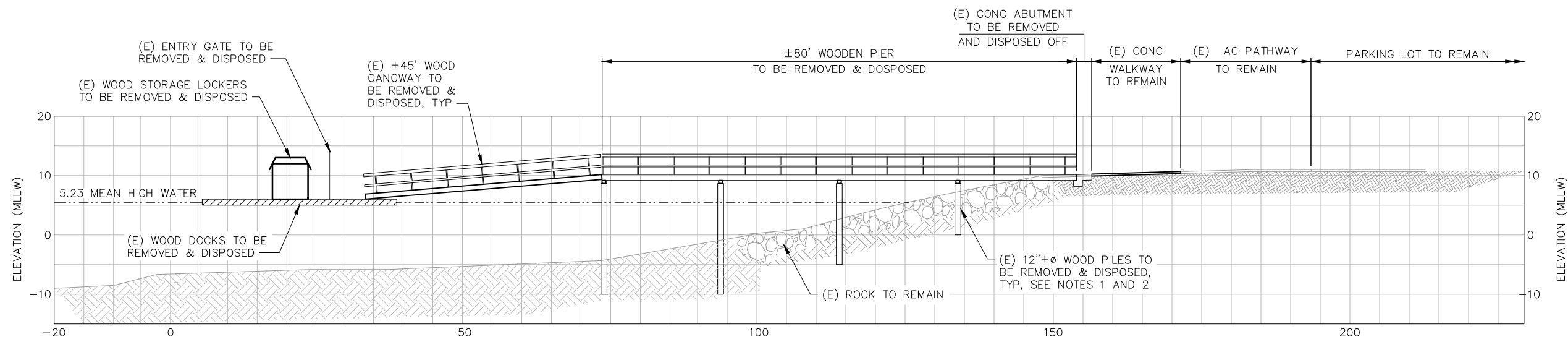

PIER AND GANGWAY DEMOLITION SECTION A
SCALE: 1" = 10'-0" D-100 D-102

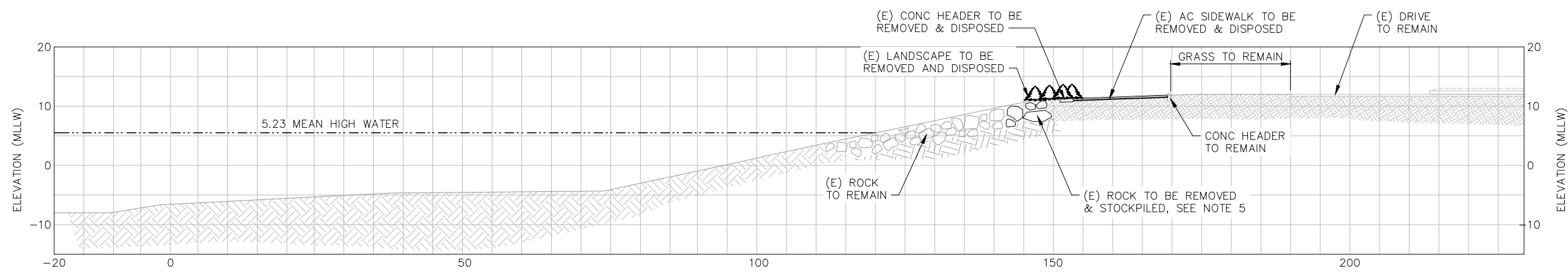

EXISTING SLOPE DEMOLITION SECTION B
SCALE: 1" = 10'-0" D-100 D-102

- NOTES:**
- EXISTING PILE EMBEDMENT UNKNOWN.
 - IF PIER AND GANGWAY PILES ARE TO BE CUT-OFF, NOTIFY THE CITY OF THE LOCATION OF THE PILES TO BE CUT-OFF. CUT-OFF LEVEL TO BE A MINIMUM OF 2' BELOW PROPOSED SURFACE AND AUTHORIZED DREDGE DEPTH.
 - FILL VOID AT REMOVED PILES WITH 3/4" AB BELOW (E) ROCK REVETMENT AND WITH ROCK FROM STOCKPILE TO DEPTH OF (E) ROCK.
 - COORDINATE DISCONNECTION OF UTILITIES AS NEEDED PRIOR TO DEMOLITION.
 - ROCK TO BE REMOVED AND STOCK PILE PRIOR TO REMOVAL AND RELOCATION OF BACK FLOW PREVENTER.

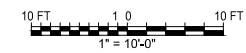
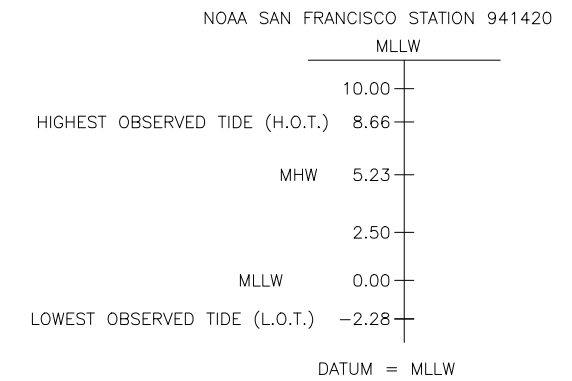

PROJECT MANAGER: _____ DATE _____	DEPICTION OF MONUMENTS: _____ DATE _____	SUBMITTED: _____ DATE _____	DESIGN: <u>JRVS</u>	HORIZ.: <u>AS SHOWN</u>
SURVEY PARTY CHIEF: _____	SURVEY PARTY CHIEF: _____	SUPERVISING CIVIL ENGINEER: _____	DRAWN: <u>NIF</u>	VERT.: _____
WATERSHED REVIEW: _____ DATE _____	APPROVED: _____ DATE _____	CITY ENGINEER: _____	CHECK: <u>JMC</u>	BOOK: _____
			AS BUILT: _____	DATE: <u>6/3/22</u>



BERKELEY MARINA DOCK REPLACEMENT (D-E)
CITY OF BERKELEY, ALAMEDA COUNTY, CALIFORNIA
DEMOLITION SECTIONS

PLAN _____
FILE _____
D-102
SHEET 8 OF 51

REVISION	MARK	DATE	DESCRIPTION	APPROVAL
A		03-27-2023	30% PROGRESS SUBMITTAL	JMC

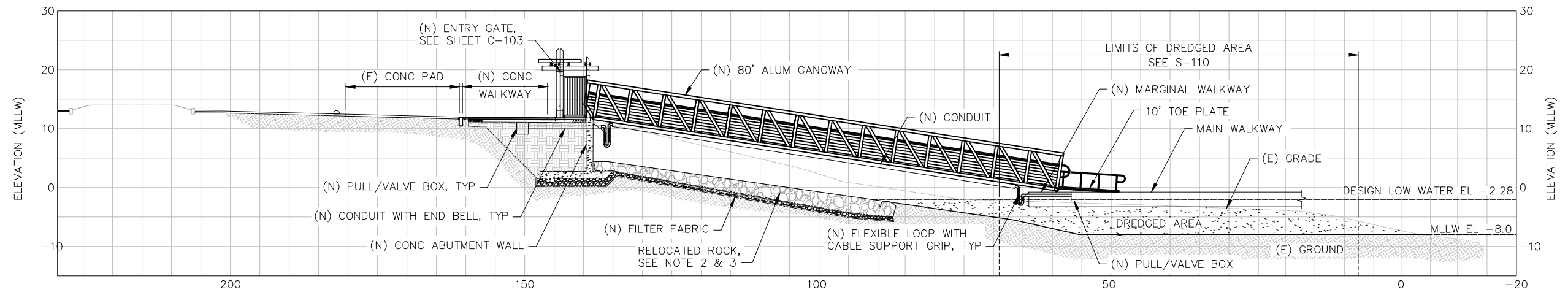

GANGWAY SECTION A
SCALE: 1" = 10'-0"

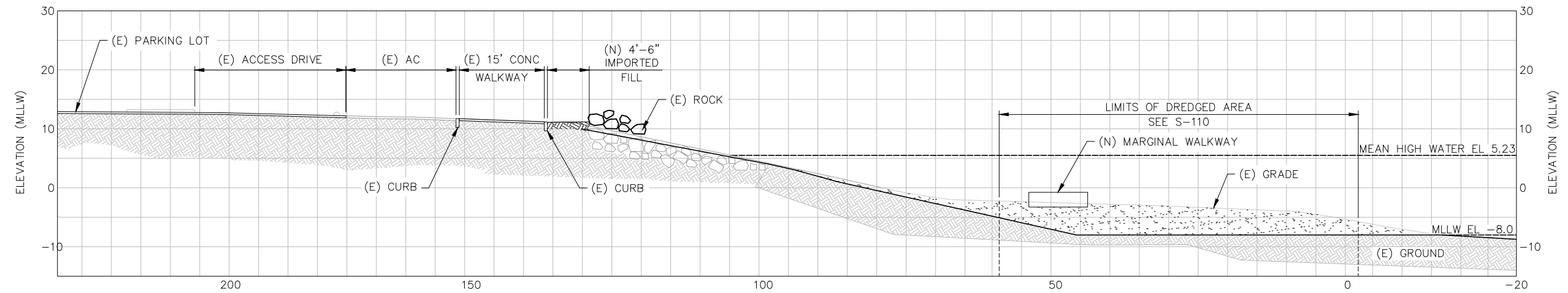

SLOPE SECTION B
SCALE: 1" = 10'-0"

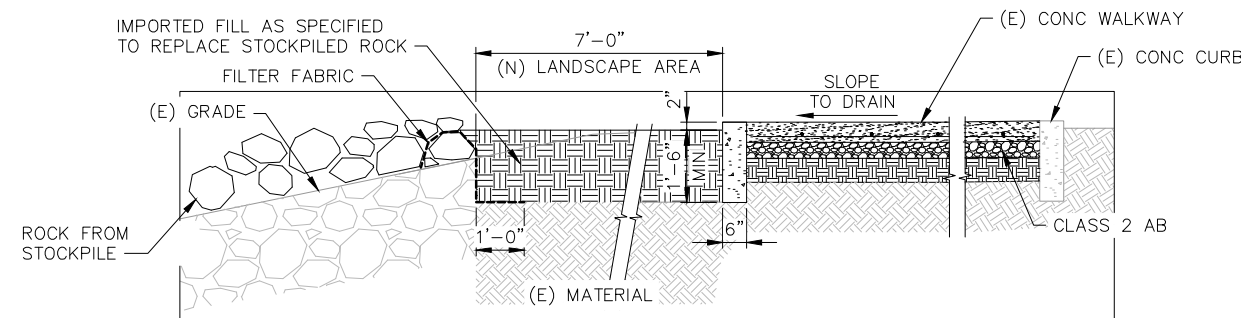

- NOTES:
1. NEW FILL TO MATCH EXISTING FILL
 2. KEY FILTER FABRIC INTO ROCK SO THAT IT IS NOT EXPOSED AND EXTEND 2' BENEATH IMPORTED FILL.

DETAIL - CURB AND FILL 1
SCALE: 1" = 10'-0"

NOAA SAN FRANCISCO STATION 941420

	MLLW
HIGHEST OBSERVED TIDE (H.O.T.)	8.66
MHW	5.23
MLLW	0.00
LOWEST OBSERVED TIDE (L.O.T.)	-2.28

DATUM = MLLW

- NOTES:
1. CONTRACTOR TO FIELD STAKE CONCRETE AREAS FOR CITY APPROVAL PRIOR TO PLACING CONCRETE. ADJUST AREAS AS NEEDED TO SATISFY CITY.
 2. SLOPE PAVED AREAS BETWEEN 1% AND 2% TO DRAIN TO LANDSCAPE AREAS AS SHOWN. FIELD VERIFY APPROPRIATE SLOPES AND MODIFY AS NEEDED TO ENSURE PROPER DRAINAGE. OBTAIN CITY APPROVAL OF FIELD MODIFICATIONS.
 3. EXISTING RIPRAP TO BE REMOVED, STOCKED PILED AND REINSTALLED ONCE FILTER FABRIC HAS BEEN INSTALLED.

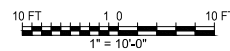

PROJECT MANAGER:	DATE	DEPICTION OF MONUMENTS:	DATE
SURVEY PARTY CHIEF:		WATERSHED REVIEW:	DATE

FOR REDUCED PLANS - ORIGINAL SCALE IS IN INCHES

SUBMITTED:	DATE	DESIGN:	DATE
SUPERVISING CIVIL ENGINEER:		DRAWN:	
APPROVED:	DATE	CHECK:	DATE
CITY ENGINEER:		AS BUILT:	DATE

HORIZ.:	AS SHOWN
VERT.:	
BOOK:	
DATE:	6/3/22

DESIGN:	JRVS
DRAWN:	NIF
CHECK:	JMC
AS BUILT:	



BERKELEY MARINA DOCK REPLACEMENT (D-E)
CITY OF BERKELEY, ALAMEDA COUNTY, CALIFORNIA
SECTIONS

PLAN
FILE
C-101
SHEET 10 OF 51

DRAFT 90% Submittal

DATE	DESCRIPTION	MARK	REVISION
05-12-2023	90% PROGRESS SUBMITTAL	JMC	
03-27-2023	60% PROGRESS SUBMITTAL	JMC	

PLOTTED BY: NIEL FORREZ PLOT DATE: 5/12/2023 11:08:23 AM

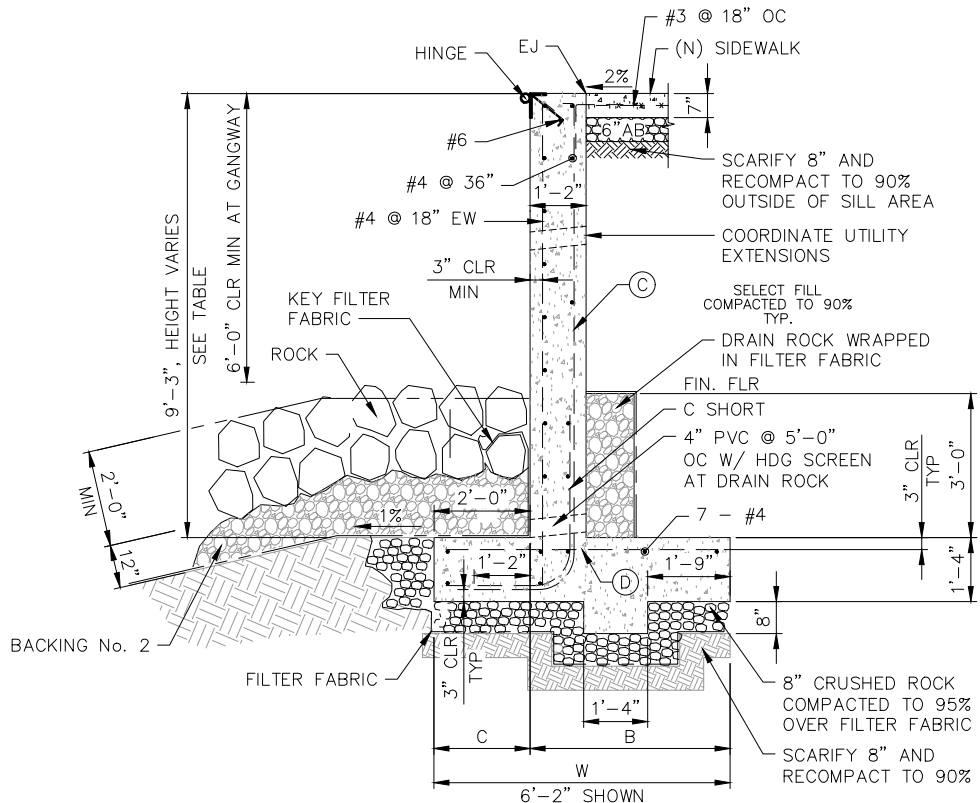

NOTES:

1. WALL HEIGHTS EXCEEDING 12' WILL REQUIRE APPROVED RE-DESIGN.
2. FIELD VERIFY WALL LOCATION TO ENSURE MINIMUM CLEARANCE BETWEEN ROCK AND BOTTOM OF GANGWAY.
3. PLACE FILTER FABRIC & CRUSHED ROCK BEDDING PRIOR ROCK. KEY FILTER FABRIC AT ALL EDGES.
4. TOP OF FOOTING TO BE FOUNDED 12" BELOW THE BOTTOM OF THE EXISTING ROCK.
5. COORDINATE LOCATION OF UTILITY CONDUITS THROUGH WALL & MAINTAIN 3" CONCRETE COVER AROUND CONDUITS.

TABLE OF DIMENSIONS				
HEIGHT, H	6'	8'	10'	12'
W	4'-2"	5'-2"	6'-2"	7'-2"
C	1'-4"	1'-8"	2'-0"	2'-4"
B	2'-10"	3'-6"	4'-2"	4'-10"
⊙ BARS	#5@18"	#5@11"	#6@9"	#7@7 1/2"
⊙ BARS	#5@18"	#5@22"	#7@18"	#7@15"

DESIGN H MAY BE EXCEEDED BY 6" BEFORE GOING TO THE NEXT SIZE. SEE CALTRANS RETAINING WALL TYPE 1A FOR ADDITIONAL INFORMATION.

SECTION - ABUTMENT WALL
SCALE: 1/2" = 1'-0"
A
C-102

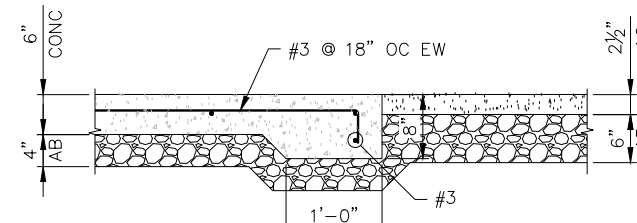

NOTE: SEE DETAILS 3 AND 4 FOR SUBGRADE AND COMPACTION REQUIREMENTS. PLACE THICKENED CONCRETE AROUND ALL EDGES AND AT JOINTS.

CONCRETE EDGE DETAIL
SCALE: 1" = 1'-0"
1
C-102

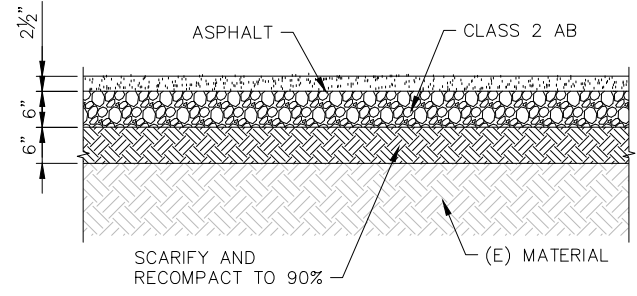

NOTES: AB TO BE COMPACTED TO 95% * 95% IN VEHICULAR TRAFFIC AREAS

TYPICAL AC PAVEMENT
SCALE: 1/16" = 1'-0"
3
C-102

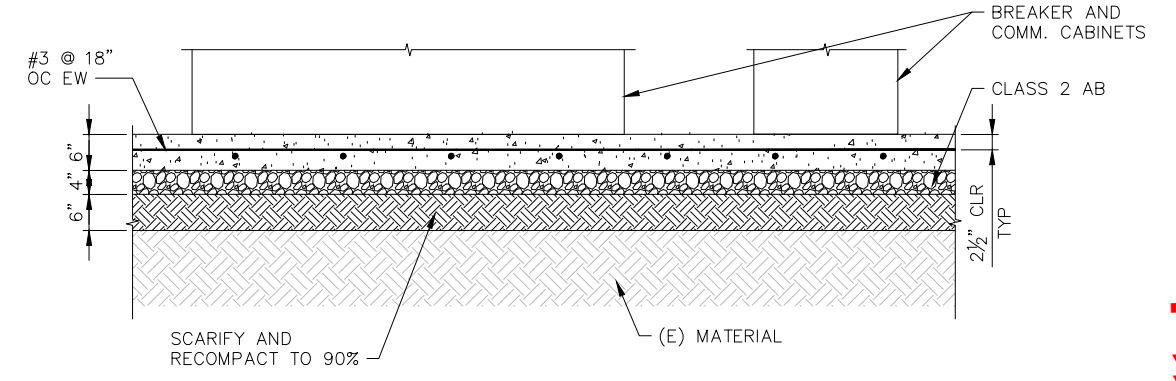

NOTE: REBAR TO BE CENTERED IN CONCRETE AB TO BE COMPACTED TO 95%. SEE DETAIL 1 FOR EDGE DETAIL.

TYPICAL CONCRETE PAVEMENT
SCALE: 1/16" = 1'-0"
2
C-102

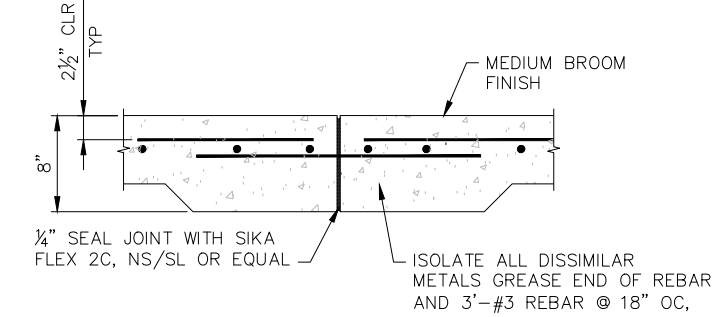

EXPANSION JOINT DETAIL
SCALE: 1" = 1'-0"
4
C-102

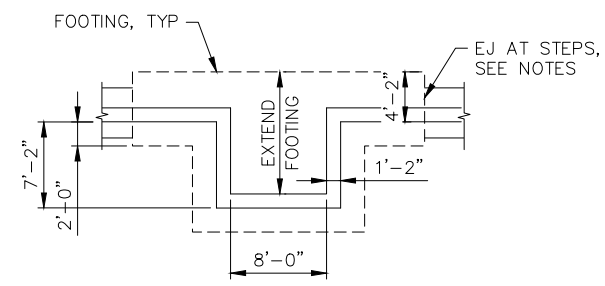

NOTE: USE 3" LONG STAINLESS STEEL SLIP DOWELS AT 12" OC TO MATCH ⊙ BARS WITHIN WALL AND FOOTING AT EXPANSION JOINTS.

ABUTMENT WALL PLAN
SCALE: 1/8" = 1'-0"
5
C-102

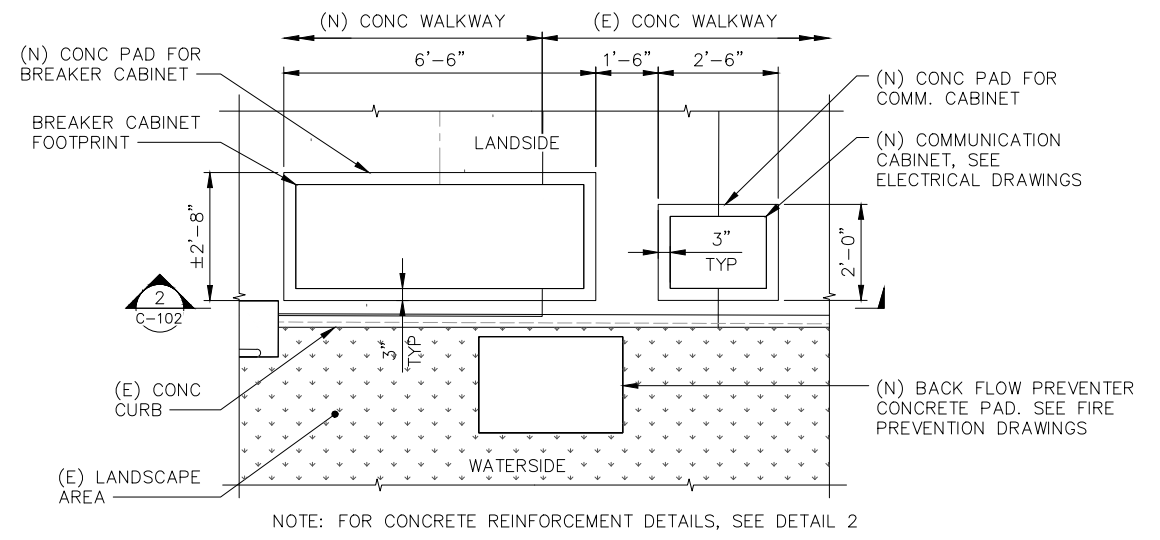

NOTE: FOR CONCRETE REINFORCEMENT DETAILS, SEE DETAIL 2

UTILITY SLAB ON GRADE
SCALE: 1/2" = 1'-0"
6
C-102

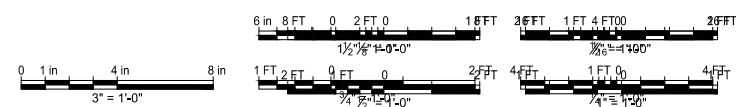

PROJECT MANAGER: _____ DATE _____	DEPICTION OF MONUMENTS: _____ DATE _____	SUBMITTED: _____ DATE _____	DESIGN: _____ DATE _____	HORIZ.: AS SHOWN		BERKELEY MARINA DOCK REPLACEMENT (D-E) CITY OF BERKELEY, ALAMEDA COUNTY, CALIFORNIA	PLAN _____
SURVEY PARTY CHIEF: _____ DATE _____	WATERSHED REVIEW: _____ DATE _____	SUPERVISING CIVIL ENGINEER: _____ DATE _____	DRAWN: _____ DATE _____	VERT.: _____		FILE _____	
APPROVED: _____ DATE _____	CITY ENGINEER: _____ DATE _____	CHECK: _____ DATE _____	BOOK: _____ DATE _____	AS BUILT: _____ DATE _____		REVISION _____	
			DATE: 8/XX/22	DATE: 8/XX/22		MARK _____	SHEET 11 OF 51

PLOTTED BY: NIEL FORTEZ PLOT DATE: 05/10/2023 11:06:26 AM

DRAFT 90% Submittal

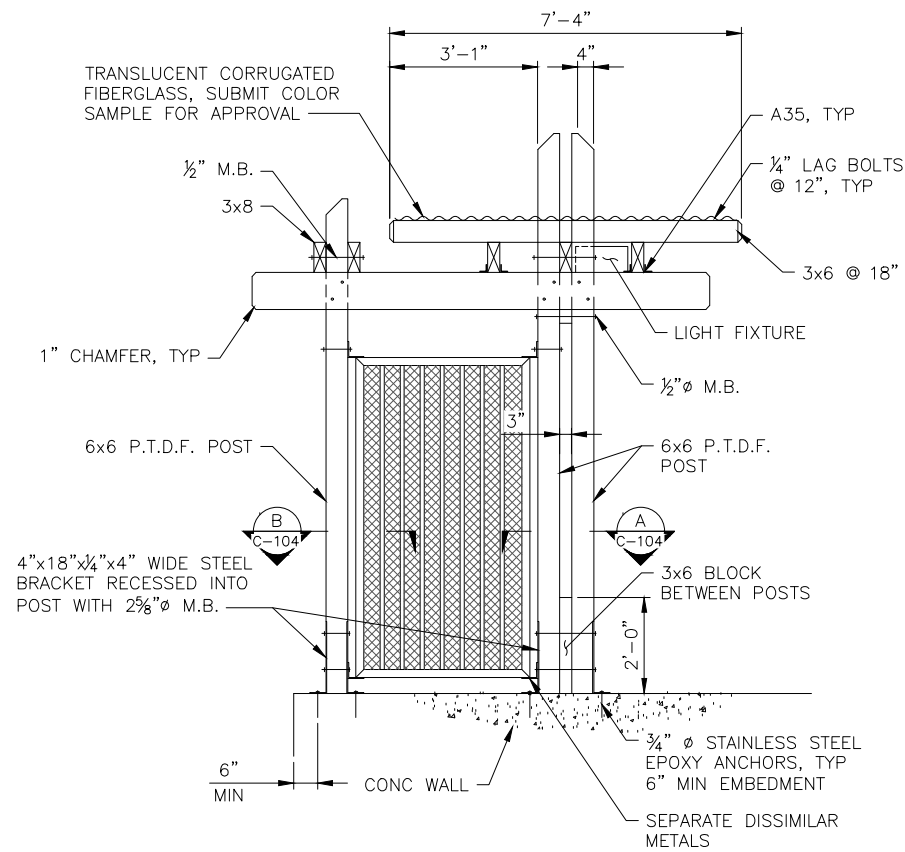
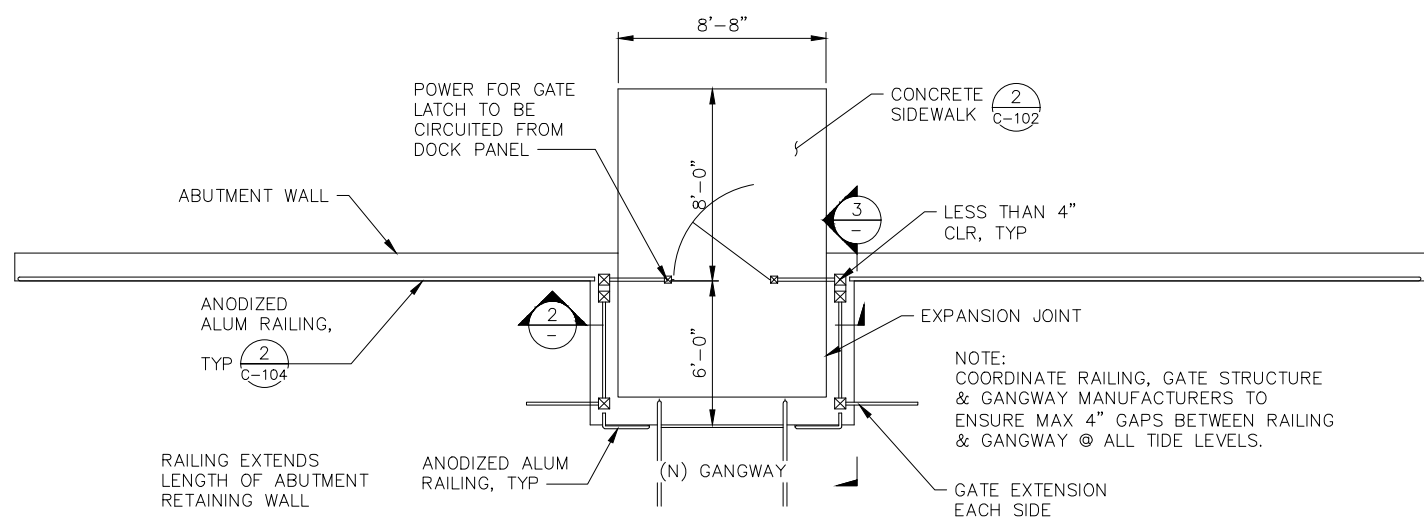

- GENERAL NOTES:**
1. ALL STEEL BRACKETS AND FASTENERS TO BE HOT DIPPED GALVANIZED.
 2. ALL BOLTS AND LAG SCREWS TO BE COUNTERSUNK & TO RECEIVE LOCK WASHERS.
 3. ALL BOLTS, LAG SCREWS AND NAILS TO BE STAINLESS STEEL.
 4. USE STAINLESS STEEL AT ALL EPOXY GROUTED ANCHORS AND AT ALUMINUM GATES AND DOORS, SEPARATE DISSIMILAR METALS
 5. ELECTRONIC STRIKE AND GATE CONTROLS TO BE FURNISHED AND INSTALLED BY ALX TECHNOLOGY (510.535.2294) OR CITY APPROVED EQUAL. COORDINATE PROPER DESIGN AND LOCATION OF LOCK SET, CONDUITS, WIRING, CONTROLS, AND BOX PRIOR TO CONCRETE AND ENTRY STRUCTURE INSTALLATION.
 6. ALL WOOD TO BE PRESSURE TREATED ACCORDING TO CITY STANDARDS.
 7. SUBMIT RAILING & GATE LAYOUT & DETAIL FOR APPROVAL.
 8. GATE STRUCTURE SIMILAR TO EXISTING GATE AT B-C DOCKS.

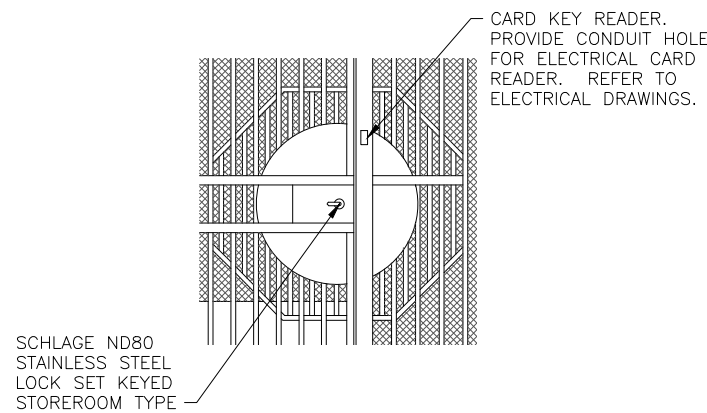
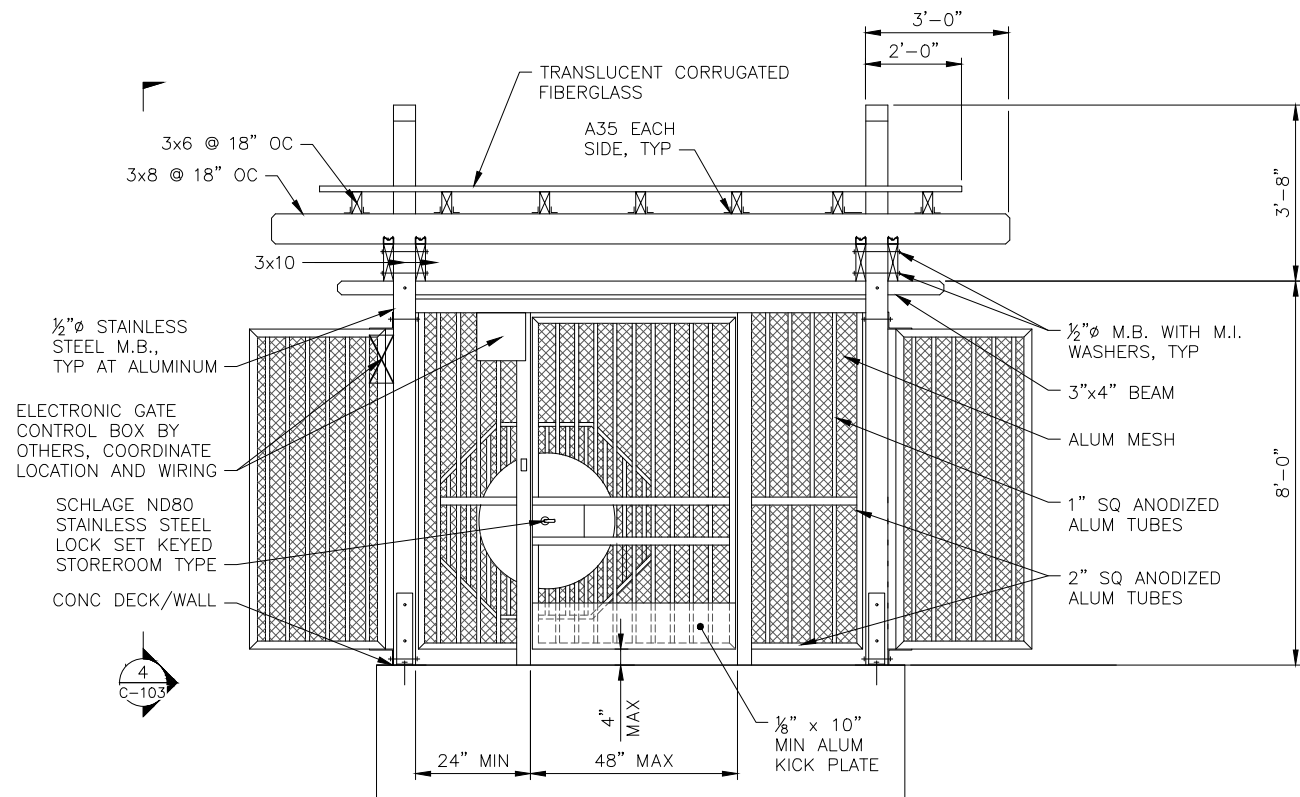

- NOTES:**
1. COORDINATE WITH GATE CARD MANUFACTURER TO ALLOW FOR INSTALLATION OF GATE SYSTEM, FURNISHED & INSTALLED BY OTHERS.
 2. ALL WOOD MEMBERS OF TRELLIS TO BE PRESSURE TREATED ROUGH SAWN DOUGLAS FIR.

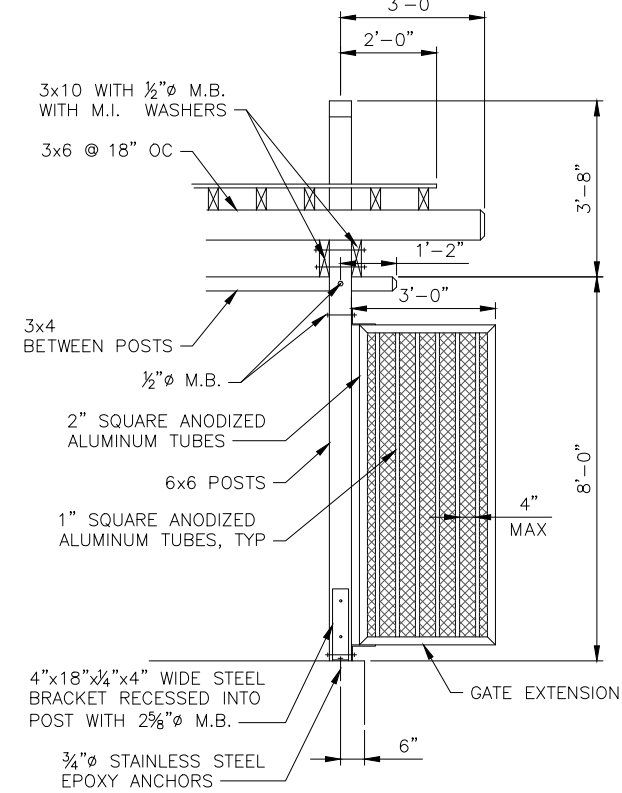

NOTE: FOR GATE EXTENSION, SEE DETAIL 4-C-103. RAILING NOT SHOWN FOR CLARITY.

PROJECT MANAGER: _____ DATE _____	DEPICTION OF MONUMENTS: _____ DATE _____	SUBMITTED: _____ DATE _____	DESIGN: _____	HORIZ.: AS SHOWN			BERKELEY MARINA DOCK REPLACEMENT (D-E) CITY OF BERKELEY, ALAMEDA COUNTY, CALIFORNIA	FILE _____
SURVEY PARTY CHIEF: _____	SUPERVISING CIVIL ENGINEER: _____	DRAWN: _____	VERT.: _____	BOOK _____				REVISION: _____
WATERSHED REVIEW: _____ DATE _____	APPROVED: _____ DATE _____	CHECK: _____	BOOK _____	DATE: 5/XX/22				MARK _____
FOR REDUCED PLANS - ORIGINAL SCALE IS IN INCHES	CITY ENGINEER: _____	AS BUILT _____	DATE: 5/XX/22	DATE: 5/XX/22				DATE: 5/XX/22

DATE	DESCRIPTION	APPROVAL
05-12-2023	90% PROGRESS SUBMITTAL	JMC
05-27-2023	60% PROGRESS SUBMITTAL	JMC

DRAFT 90% Submittal

GENERAL NOTES:

1. ALL STEEL BRACKETS AND FASTENERS TO BE HOT DIPPED GALVANIZED.
2. ALL BOLTS AND LAG SCREWS TO BE COUNTERSUNK & TO RECEIVE LOCK WASHERS.
3. ALL BOLTS, LAG SCREWS AND NAILS TO BE STAINLESS STEEL.
4. USE STAINLESS STEEL AT ALL EPOXY GROUTED ANCHORS AND AT ALUMINUM GATES AND DOORS, SEPARATE DISSIMILAR METALS
5. ELECTRONIC STRIKE AND GATE CONTROLS TO BE FURNISHED AND INSTALLED BY ALX TECHNOLOGY (510.535.2294). COORDINATE PROPER DESIGN AND LOCATION OF LOCK SET, CONDUITS, WIRING, CONTROLS, AND BOX PRIOR TO CONCRETE AND ENTRY STRUCTURE INSTALLATION.
6. ALL WOOD TO BE PRESSURE TREATED ACCORDING TO CITY STANDARDS.
7. SUBMIT RAILING & GATE LAYOUT & DETAIL FOR APPROVAL.
8. GATE STRUCTURE SIMILAR TO EXISTING GATE AT B-C DOCKS.

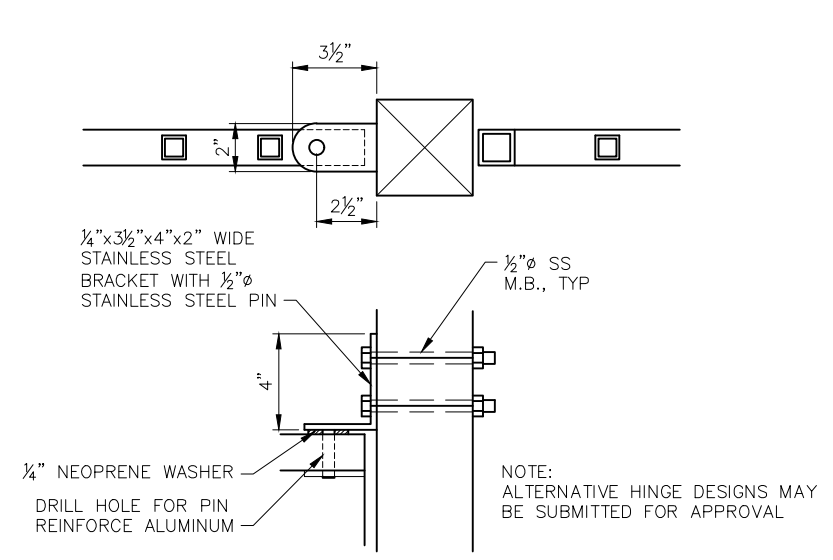

DOOR HINGE DETAIL (1)
SCALE: 3" = 1'-0"
C-104

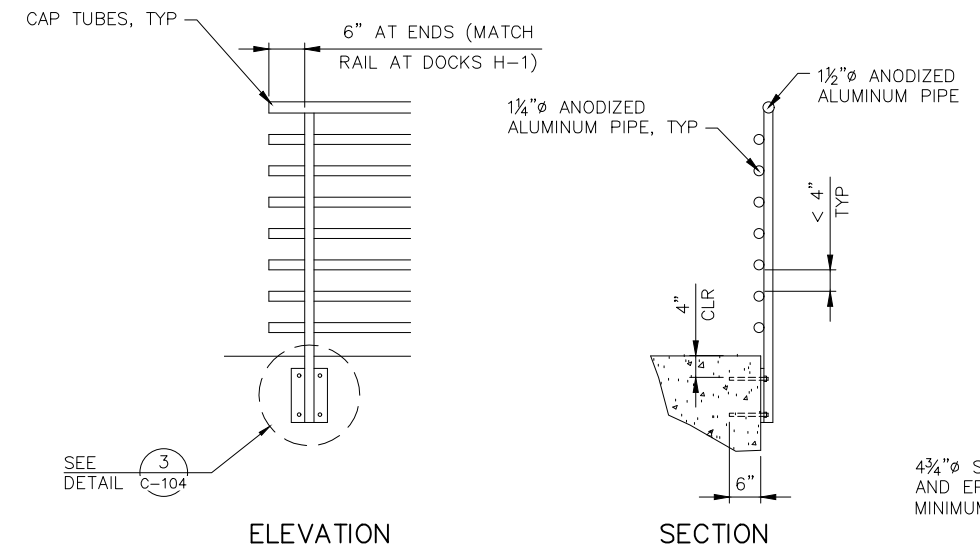

RAILING DETAIL (2)
SCALE: 3/4" = 1'-0"
C-104

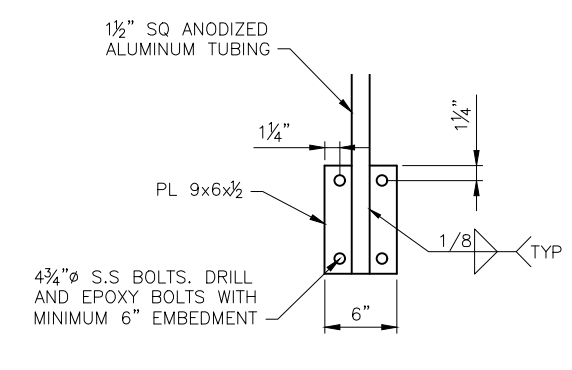

RAILING DETAIL (3)
SCALE: 1 1/2" = 1'-0"
C-104

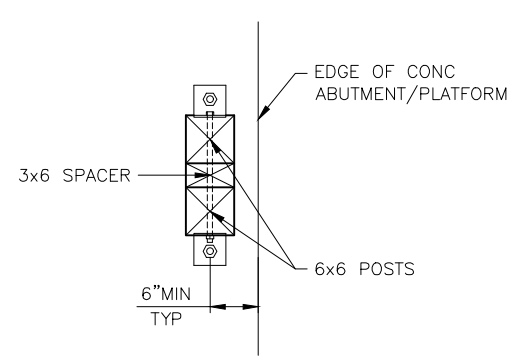

POST CONNECTION DETAIL (A)
SCALE: 1" = 1'-0"
C-104

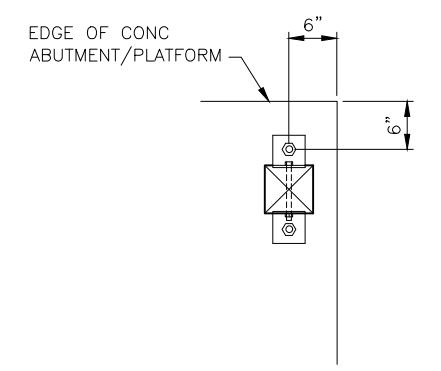

POST CONNECTION DETAIL (B)
SCALE: 1" = 1'-0"
C-104

PROJECT MANAGER: _____ DATE: _____	DEPICTION OF MONUMENTS: _____ DATE: _____	SUBMITTED: _____ DATE: _____	DESIGN: <u>JRVS</u> HORIZ.: <u>AS SHOWN</u>
_____	_____	_____	VERT.: _____
SURVEY PARTY CHIEF: _____	WATERSHED REVIEW: _____ DATE: _____	SUPERVISING CIVIL ENGINEER: _____	CHECK: <u>JMC</u> BOOK: _____
_____	_____	APPROVED: _____ DATE: _____	AS BUILT: _____ DATE: <u>8/XX/22</u>
PROJECT: BERKELEY MARINA DOCK REPLACEMENT (D-E) CITY OF BERKELEY, ALAMEDA COUNTY, CALIFORNIA			PLAN: _____ FILE: _____ SHEET: C-104 OF 51

REVISION	MARK	DATE	DESCRIPTION	APPROVAL
B		05-12-2023	90% PROGRESS SUBMITTAL	JMC
A		03-27-2023	60% PROGRESS SUBMITTAL	JMC

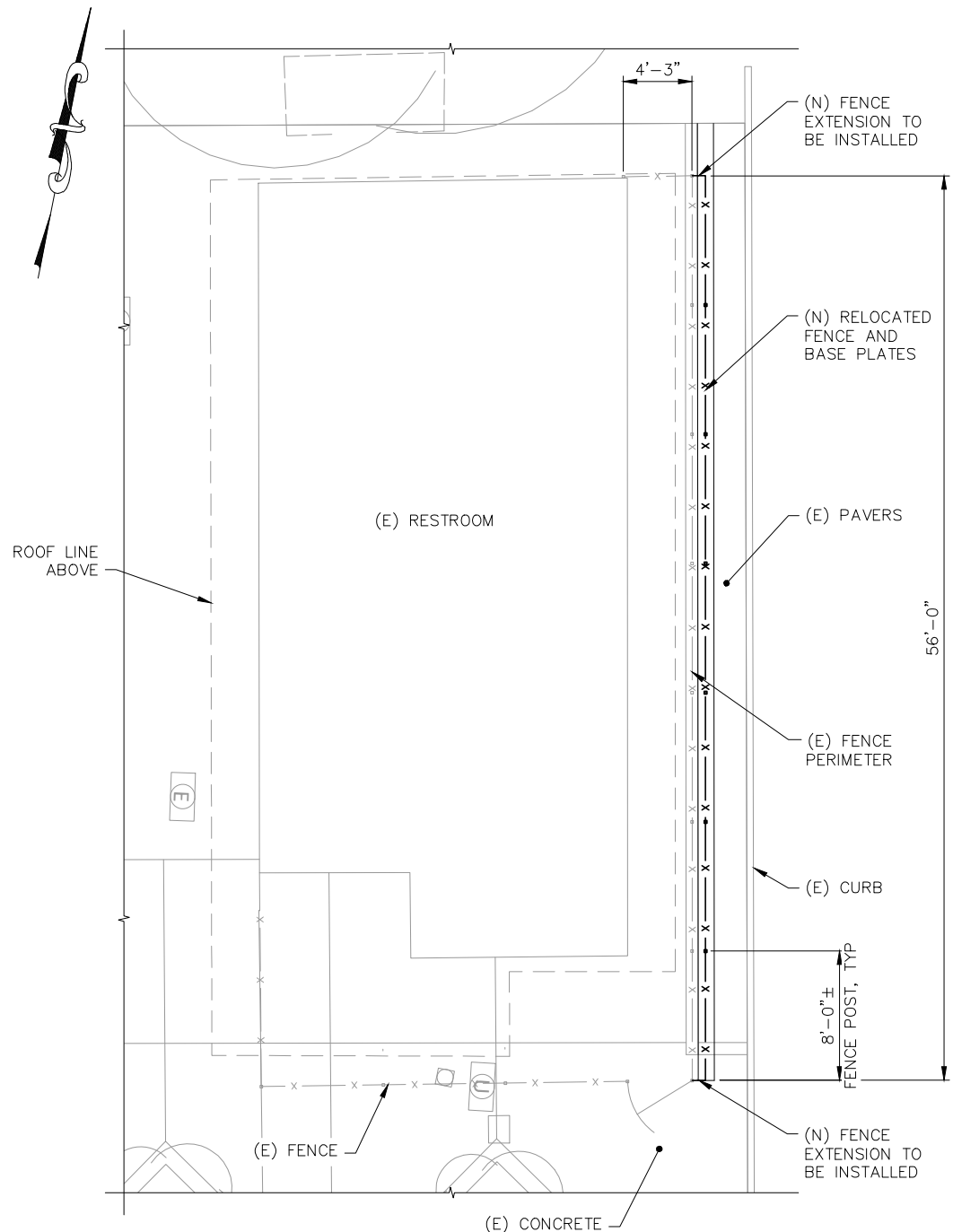

EXISTING FENCE RELOCATION PLAN 1
SCALE: 3/16" = 1'-0"
C-100

LEGEND:
- x - x - (E) RESTROOM FENCE

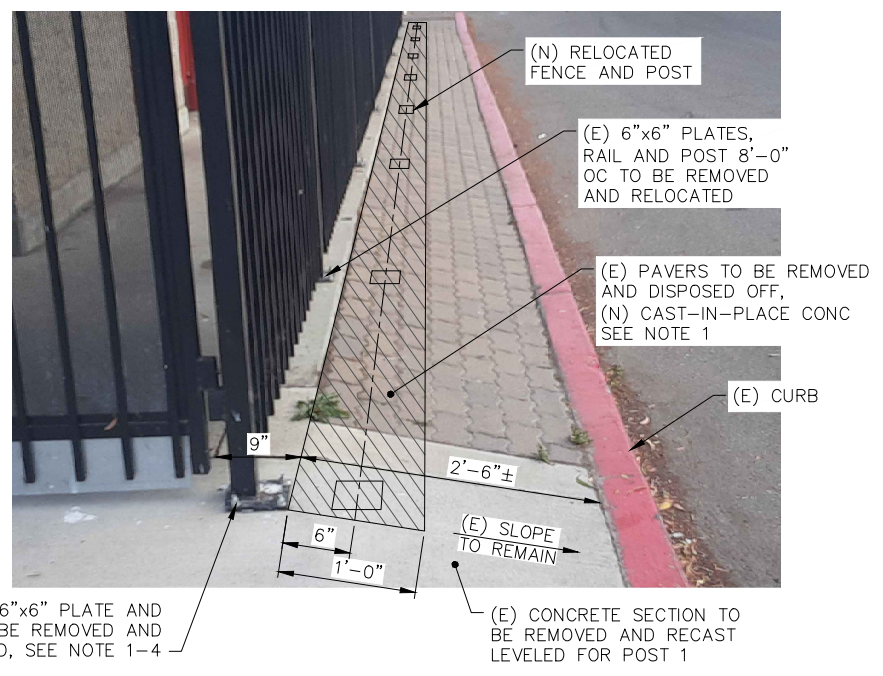

EXISTING EAST END FENCE AND PATHWAY LOOKING WEST 2
SCALE: NTS
C-100

- GENERAL NOTES**
1. REMOVE AND DISPOSE OFF SLOPPED PAVERS AND CONCRETE AS NOTED.
 2. LEVEL EXISTING SOIL PRIOR TO CONCRETE POUR.
 3. NEW CAST-IN-PLACE CONCRETE TO BE FLUSHED WITH EXISTING ADA PATH WAY ON WEST END OF NEW FENCE.
 4. EXISTING PAVERS TO FOLLOW EXISTING SLOPE GRADE.
 5. ADA DOMES TO BE INSTALLED ON LEVEL SURFACE.
 6. ANCHOR BOLTS FOR RELOCATED FENCE AND TRUNCATED DOME PADS TO BE INSTALLED PER MANUFACTURERS RECOMMENDATIONS.
 7. FOR SOUTH END PAD, PROVIDE OPENING TO ACCOMMODATE EXISTING BOLLARD AND SHIFT ANCHOR BOLT HOLE AS NEEDED.

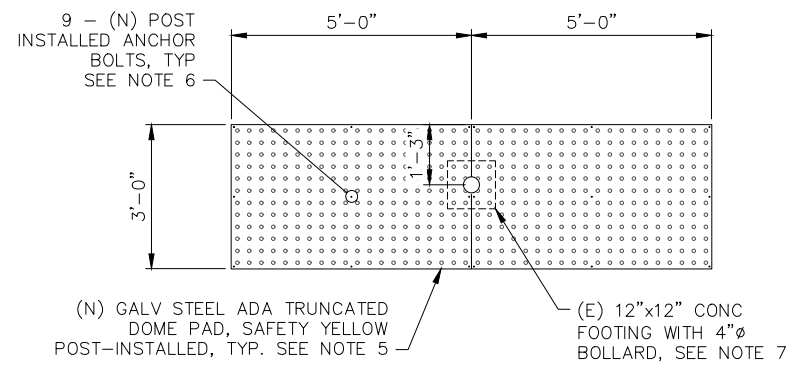

ADA TRUNCATED DOMES 4
SCALE: 1/2" = 1'-0"
C-100



EXISTING NORTH END FENCE LOOKING WEST 3
SCALE: NTS
C-100

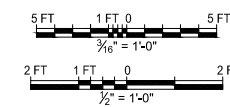

PROJECT MANAGER: _____ DATE _____	DEPICTION OF MONUMENTS: _____ DATE _____	SUBMITTED: _____ DATE _____	DESIGN: <u>JRVS</u>	HORIZ.: <u>AS SHOWN</u>	 COWI <small>1212 15th Street, 15th Floor, Berkeley, CA 94712</small> <small>TEL: 510.863.8977 FAX: 510.863.9755</small> <small>PHOTOS RECREATION & WATERWORKS</small> <small>1847 CENTER ST., 9th FL, BERKELEY, CA 94704</small>	BERKELEY MARINA DOCK REPLACEMENT (D-E)	PLAN _____
SURVEY PARTY CHIEF _____	WATERSHED REVIEW: _____ DATE _____	SUPERVISING CIVIL ENGINEER _____	DRAWN: <u>NIF</u>	VERT.: _____		CITY OF BERKELEY, ALAMEDA COUNTY, CALIFORNIA	FILE _____
APPROVED: _____	CITY ENGINEER _____	AS BUILT _____	CHECK: <u>JMC</u>	BOOK _____		RESTROOM FENCE RELOCATION PLAN	C-105
					DATE: <u>5/XX/22</u>	REVISION: _____	SHEET 14 OF 51

REVISION	MARK	DATE	DESCRIPTION	APPROVAL
B		05-12-2023	90% PROGRESS SUBMITTAL	JMC
A		03-27-2023	60% PROGRESS SUBMITTAL	JMC

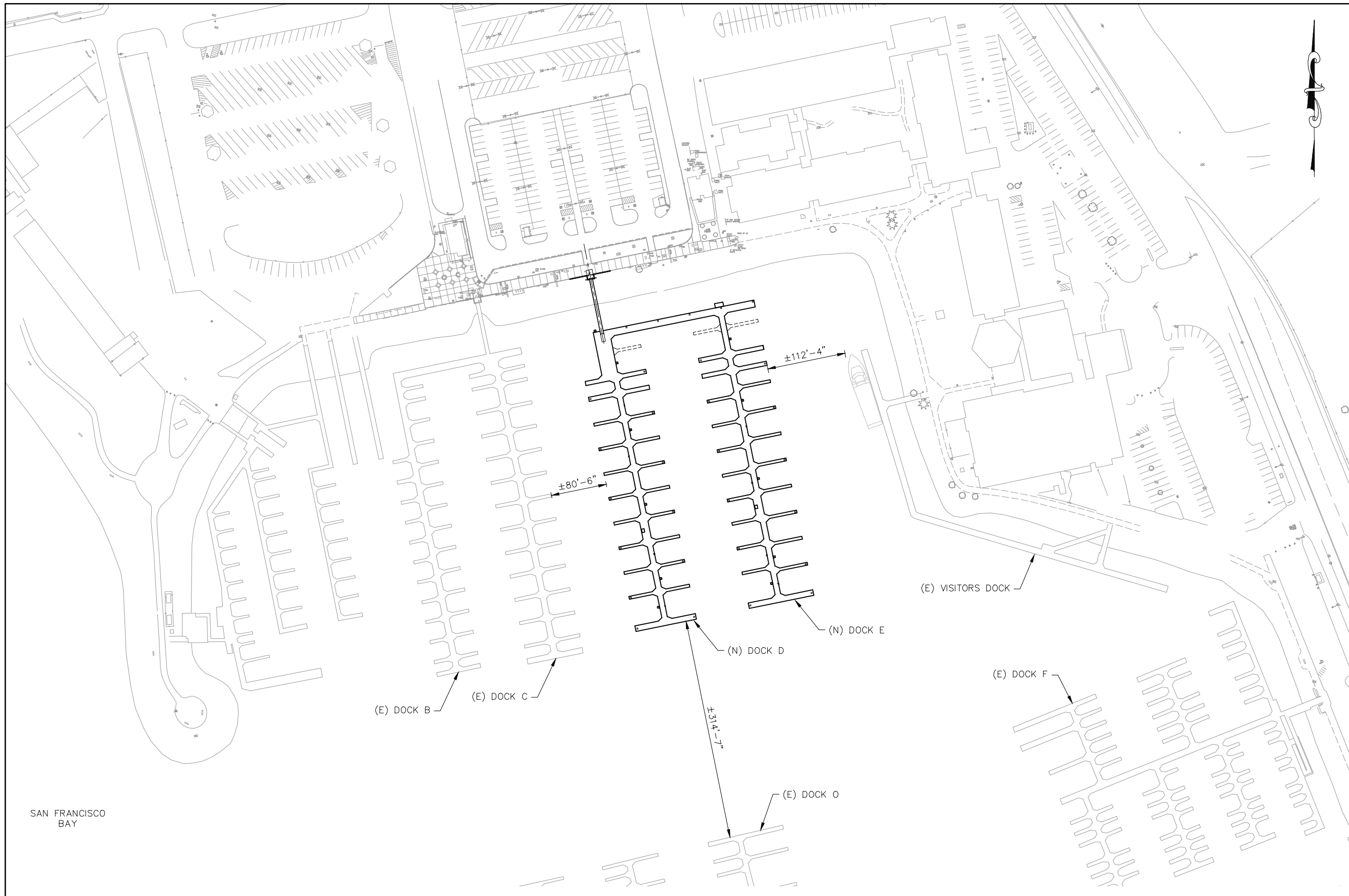

SAN FRANCISCO BAY

SITE PLAN
SCALE: 1" = 70'-0"
1
S-001

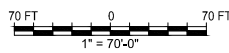

PROJECT MANAGER:	DATE	DEPICTION OF MONUMENTS:	DATE
SURVEY PARTY CHIEF:		WATERSHED REVIEW:	DATE

FOR REDUCED PLANS - ORIGINAL SCALE IS IN INCHES

SUBMITTED:	DATE	DESIGN	URVS	HORIZ.	AS SHOWN
R.C.E.		DRAWN	NIF	VERT.	
SUPERVISING CIVIL ENGINEER	EXP.	CHECK	JMC	BOOK	
APPROVED:	DATE	AS BUILT		DATE	6/3/22
R.C.E.					
CITY ENGINEER	EXP.				

DESIGN	URVS	HORIZ.	AS SHOWN
DRAWN	NIF	VERT.	
CHECK	JMC	BOOK	
AS BUILT		DATE	6/3/22



BERKELEY MARINA DOCK REPLACEMENT (D-E)
CITY OF BERKELEY, ALAMEDA COUNTY, CALIFORNIA
SITE PLAN

REVISION	MARK	DATE	DESCRIPTION	APPROVAL
C		05-12-2023	50% PROGRESS SUBMITTAL	JMC
B		03-27-2023	60% PROGRESS SUBMITTAL	JMC
A		06-03-2022	30% PROGRESS SUBMITTAL	JMC

PLAN FILE S-001 SHEET 15 OF 51

DRAFT 90% Submittal

DRAFT 90% Submittal

GENERAL NOTES FOR ALL FABRICATIONS:

1. THE CONTRACTOR SHALL SUBMIT SHOP DRAWINGS AND CALCULATIONS IN ACCORDANCE WITH THE CONTRACT DOCUMENTS PRIOR TO FABRICATION OF ALL COMPONENTS.
2. ALL ALUMINUM MATERIALS SHALL RECEIVE A LIGHT SAND BLAST FINISH AFTER FABRICATION.
3. ALL MATERIAL SIZES, SCHEDULES, AND DIMENSIONS SHOWN ON THESE PLANS ARE TO BE CONSIDERED MINIMUM REQUIRED. CALCULATIONS AND SHOP DRAWINGS MAY REQUIRE ADDITIONAL/LARGER/STRONGER MATERIALS.
4. GANGWAY SHALL BE SIMILAR IN APPEARANCE AS B & C GANGWAY.
5. ALTERNATIVE HINGE DETAIL MAY BE SUBMITTED FOR CONSIDERATION.

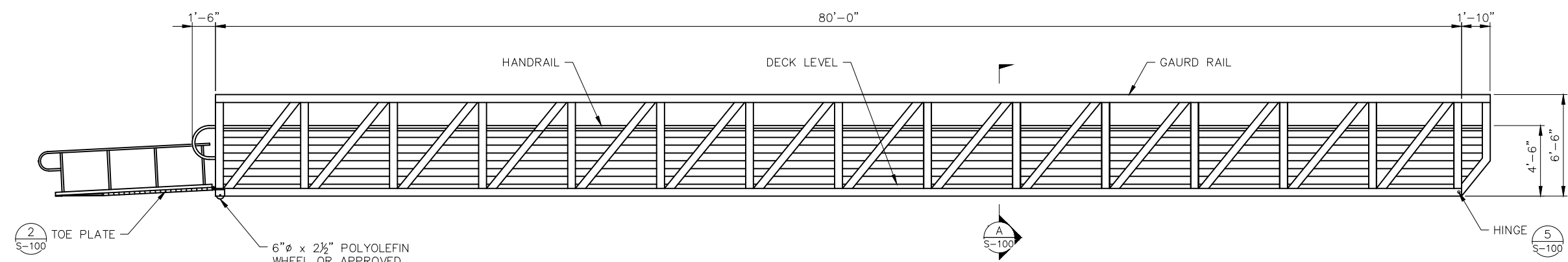

ACCESSIBLE GANGWAY (1)
SCALE: 1/4" = 1'-0"

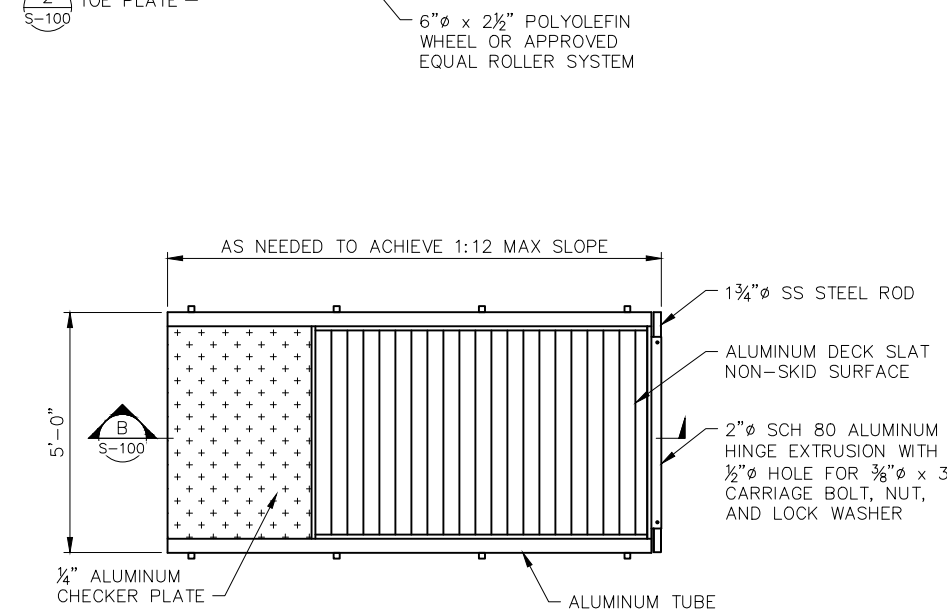

TOE PLATE (2)
SCALE: 3/4" = 1'-0"

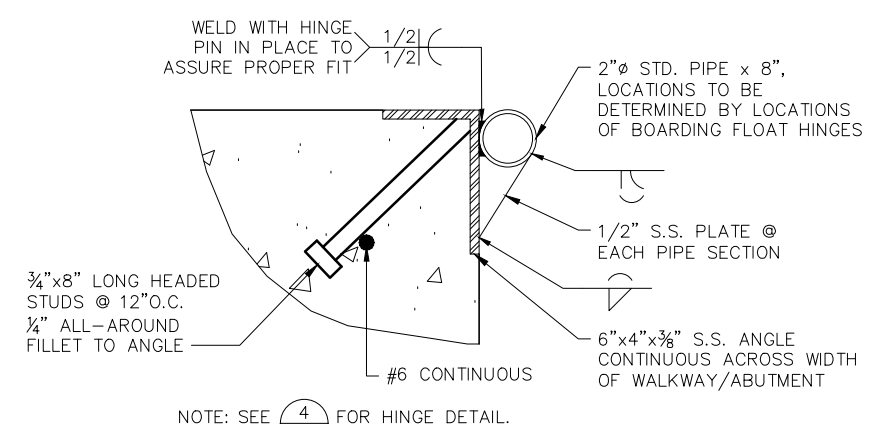

HINGE DETAIL (3)
SCALE: 3" = 1'-0"

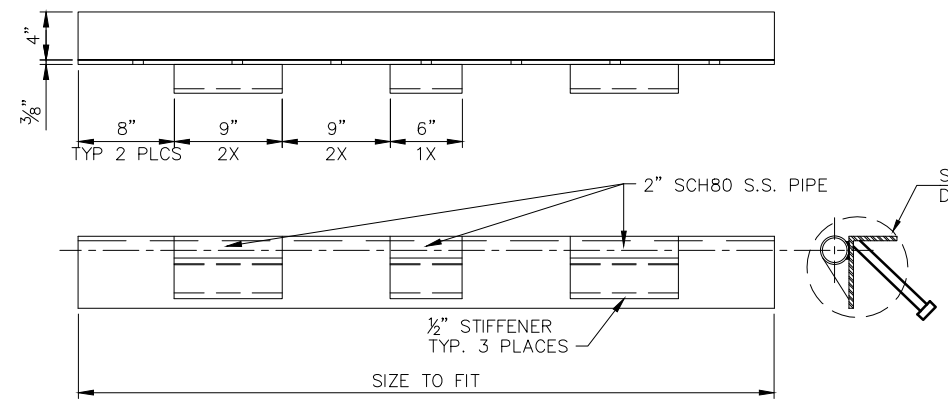

ABUTMENT HINGE DETAIL (4)
SCALE: 1 1/2" = 1'-0"

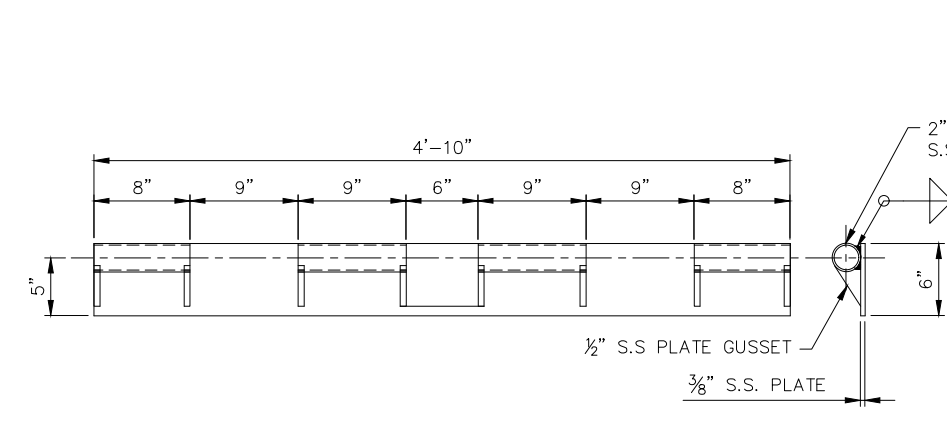

GANGWAY HINGE DETAIL (5)
SCALE: 1 1/2" = 1'-0"

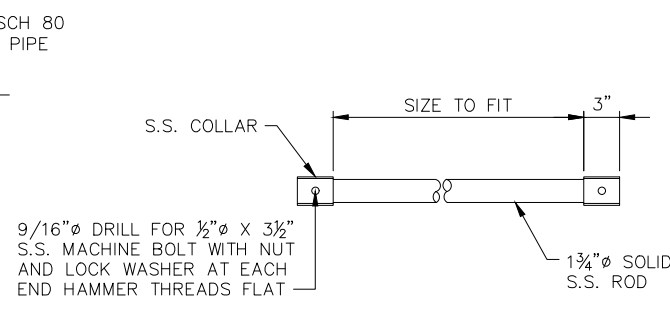

ABUTMENT HINGE PIN DETAIL (6)
SCALE: 1 1/2" = 1'-0"

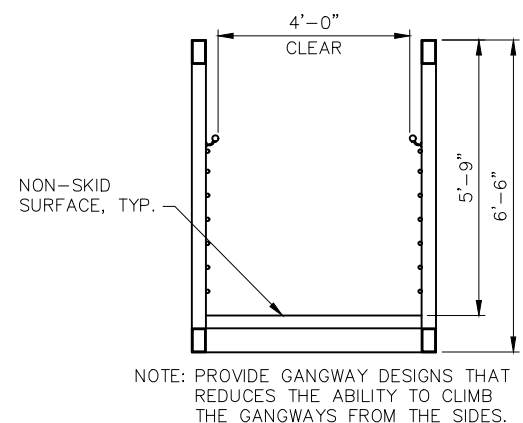

GANGWAY SECTION (A)
SCALE: 1/2" = 1'-0"

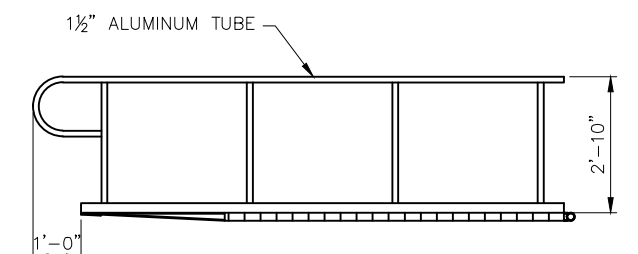

TOE PLATE SECTION (B)
SCALE: 1" = 1'-0"

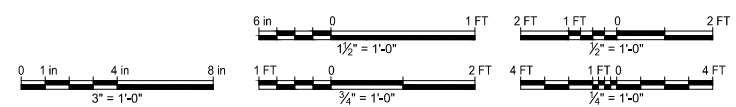

PROJECT MANAGER: _____ DATE _____	DEPICTION OF MONUMENTS: _____ DATE _____	SUBMITTED: _____ DATE _____	DESIGN: JRVS	HORIZ.: AS SHOWN			BERKELEY MARINA DOCK REPLACEMENT (D-E) CITY OF BERKELEY, ALAMEDA COUNTY, CALIFORNIA GANGWAY DETAILS SHEET 1 OF 2	PLAN _____
SURVEY PARTY CHIEF: _____ DATE _____	SURVEY PARTY CHIEF: _____ DATE _____	SUPERVISING CIVIL ENGINEER: _____ DATE _____	DRAWN: NIF	VERT.: _____				FILE _____
WATERSHED REVIEW: _____ DATE _____	WATERSHED REVIEW: _____ DATE _____	APPROVED: _____ DATE _____	CHECK: JMC	BOOK: _____				REVISION _____
FOR REDUCED PLANS - ORIGINAL SCALE IS IN INCHES	CITY ENGINEER: _____ DATE _____	CITY ENGINEER: _____ DATE _____	AS BUILT	DATE: 6/3/22				MARK _____

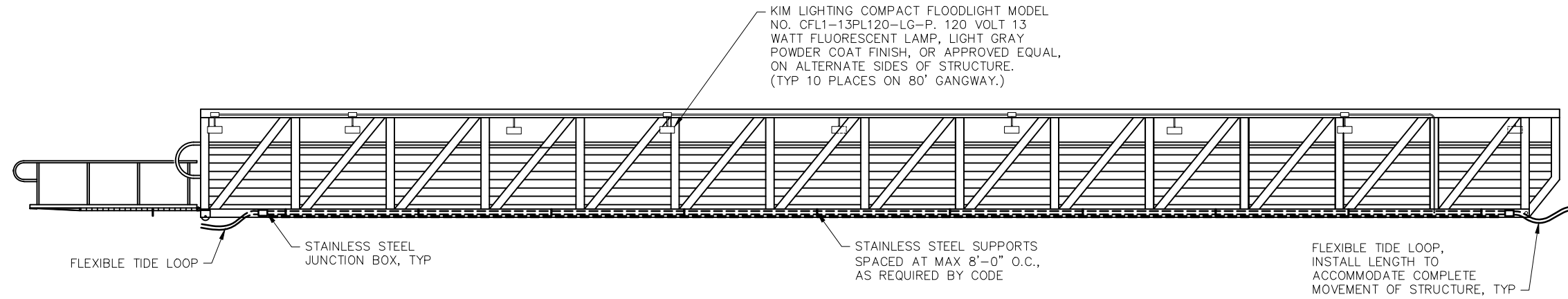

TYPICAL LIGHTING ON 80' GANGWAY
SCALE: 1/4" = 1'-0" 1
S-101

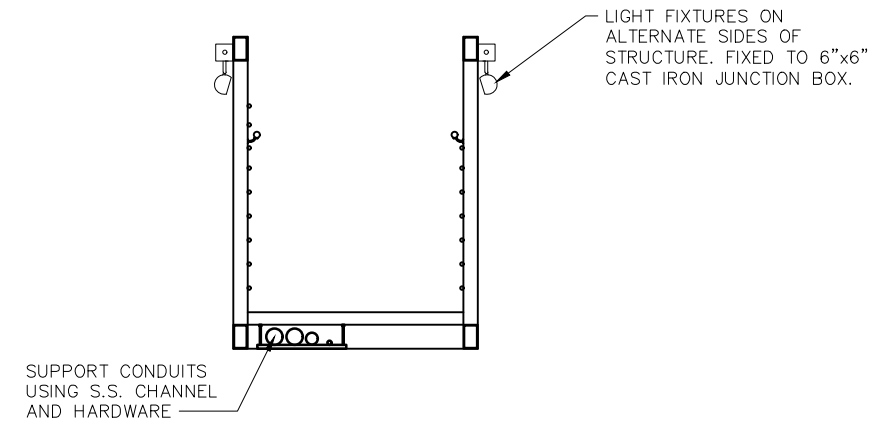

NOTE: ACTUAL GANGWAY AND UTILITY LINES DETAILS MAY VARY FROM SHOWN. PROVIDE GANGWAY DESIGN THAT REDUCES ABILITY TO CLIMB ONTO GANGWAY FROM SIDES

TYPICAL GANGWAY SECTION
SCALE: 1/2" = 1'-0" A
S-101

- GENERAL NOTES FOR ALL FABRICATIONS:
1. THE CONTRACTOR SHALL SUBMIT SHOP DRAWINGS AND CALCULATIONS IN ACCORDANCE WITH THE CONTRACT DOCUMENTS PRIOR TO FABRICATION OF ALL COMPONENTS.
 2. ALL ALUMINUM MATERIALS SHALL RECEIVE A LIGHT SAND BLAST FINISH AFTER FABRICATION.
 3. ALL MATERIAL SIZES, SCHEDULES, AND DIMENSIONS SHOWN ON THESE PLANS ARE TO BE CONSIDERED MINIMUM REQUIRED. CALCULATIONS AND SHOP DRAWINGS MAY REQUIRE ADDITIONAL/LARGER/STRONGER MATERIALS.
 4. SEE E-SHEETS FOR ADDITIONAL GANGWAY LIGHTING DETAILS.
 5. GANGWAY SHALL BE SIMILAR IN APPEARANCE AS & C GANGWAY.

DRAFT 90% Submittal

REVISION	MARK	DATE	DESCRIPTION	APPROVAL
C		05-12-2023	50% PROGRESS SUBMITTAL	JMC
B		03-27-2023	60% PROGRESS SUBMITTAL	JMC
A		06-03-2022	30% PROGRESS SUBMITTAL	JMC

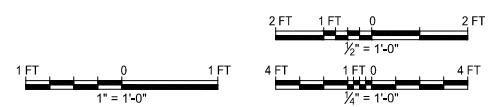

PROJECT MANAGER: _____ DATE _____	DEPICTION OF MONUMENTS: _____ DATE _____	SUBMITTED: _____ DATE _____	DESIGN: <u>JRVS</u>	HORIZ.: <u>AS SHOWN</u>	 COWI <small>1311 15th Street, 19th Floor, Berkeley, CA 94702 Tel: 510.868.8972 Fax: 510.868.9752</small>	BERKELEY MARINA DOCK REPLACEMENT (D-E) CITY OF BERKELEY, ALAMEDA COUNTY, CALIFORNIA GANGWAY DETAILS SHEET 2 OF 2	PLAN _____ FILE _____ S-101 SHEET 17 OF 51
SURVEY PARTY CHIEF: _____	WATERSHED REVIEW: _____ DATE _____	SUPERVISING CIVIL ENGINEER: _____	DRAWN: <u>NIF</u>	VERT.: _____			
APPROVED: _____	CITY ENGINEER: _____	CHECK: <u>JMC</u>	BOOK: _____	DATE: <u>6/3/22</u>			
FOR REDUCED PLANS - ORIGINAL SCALE IS IN INCHES		AS BUILT: _____					

DRAFT 90% Submittal

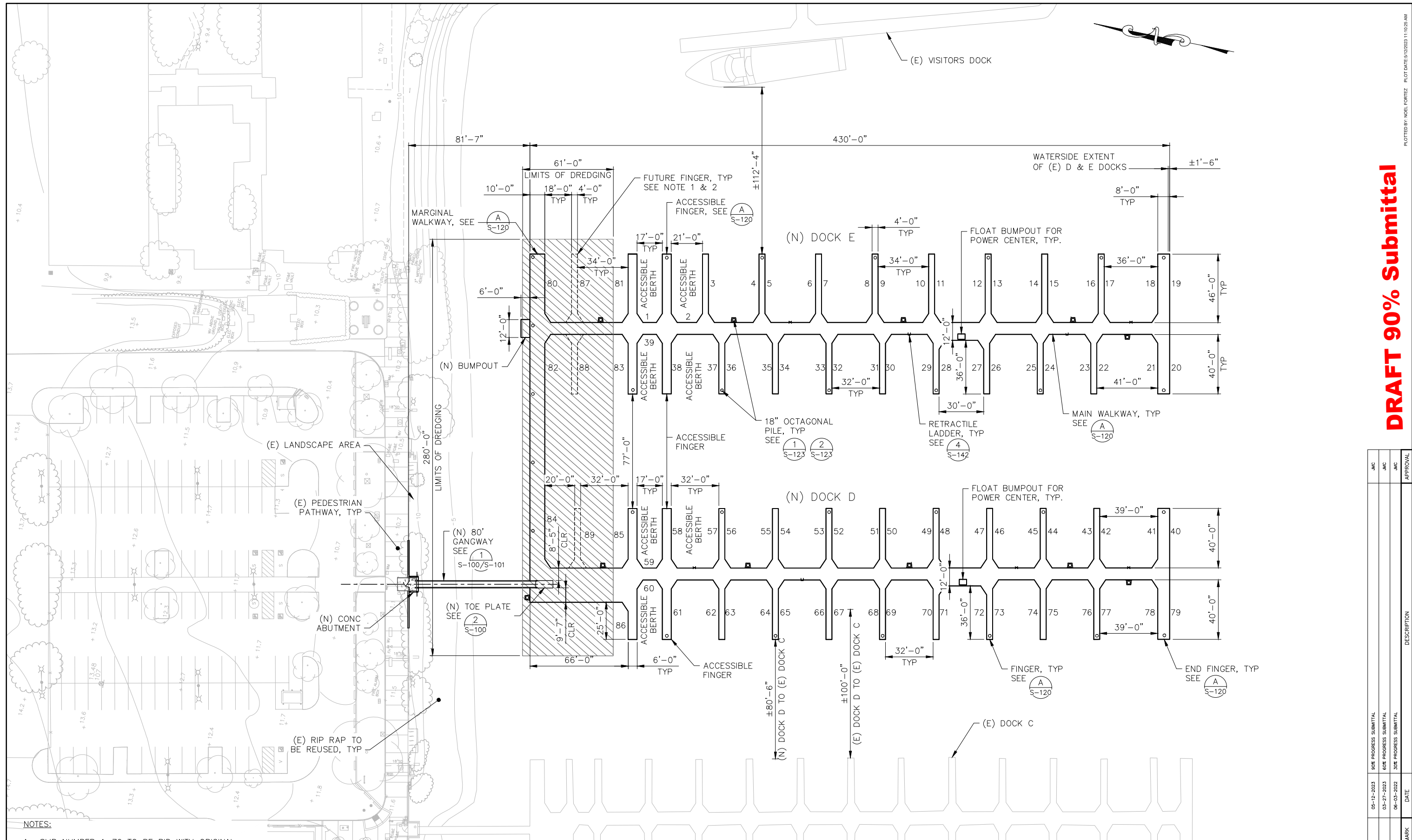

- NOTES:**
1. SLIP NUMBER 1-79 TO BE BID WITH ORIGINAL DESIGN. SLIPS 80-89 TO BE BUILT AT FUTURE STAGE.
 2. STRUCTURAL INSERTS AND CONDUITS FOR ELECTRICAL, MECHANICAL, PLUMBING ITEMS TO BE INCORPORATED IN DESIGN FOR FUTURE SLIPS 80-89.
 3. PILE LOCATIONS SHOWN ARE PRELIMINARY. FINAL PILE LOCATION TO BE DETERMINED BY DESIGN BUILD TEAM.

NEW DOCK PLAN
SCALE: 1" = 30'-0"

1
S-110

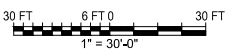

PROJECT MANAGER:	DATE:	DEPICTION OF MONUMENTS:	DATE:	SUBMITTED:	DATE:	DESIGN:	DATE:	HORIZ.:	AS SHOWN
		SURVEY PARTY CHIEF:		DRAWN:	R.C.E.:	DRAWN:	R.C.E.:	VERT.:	
		WATERSHED REVIEW:	DATE:	SUPERVISING CIVIL ENGINEER:	EXP.:	CHECK:	R.C.E.:	BOOK:	
				APPROVED:	DATE:	CHECK:	R.C.E.:	BOOK:	
				CITY ENGINEER:	EXP.:	AS BUILT:	EXP.:	DATE:	6/3/22

DESIGN:	JRVS	HORIZ.:	AS SHOWN
DRAWN:	NIF	VERT.:	
CHECK:	JMC	BOOK:	
AS BUILT:		DATE:	6/3/22



BERKELEY MARINA DOCK REPLACEMENT (D-E)
CITY OF BERKELEY, ALAMEDA COUNTY, CALIFORNIA
NEW DOCK PLAN
79 SLIP LAYOUT

REVISION	MARK	DATE	DESCRIPTION	APPROVAL
C		05-12-2023	60% PROGRESS SUBMITTAL	JMC
B		03-27-2023	60% PROGRESS SUBMITTAL	JMC
A		06-03-2022	30% PROGRESS SUBMITTAL	JMC

FILE: S-110
SHEET 18 OF 51

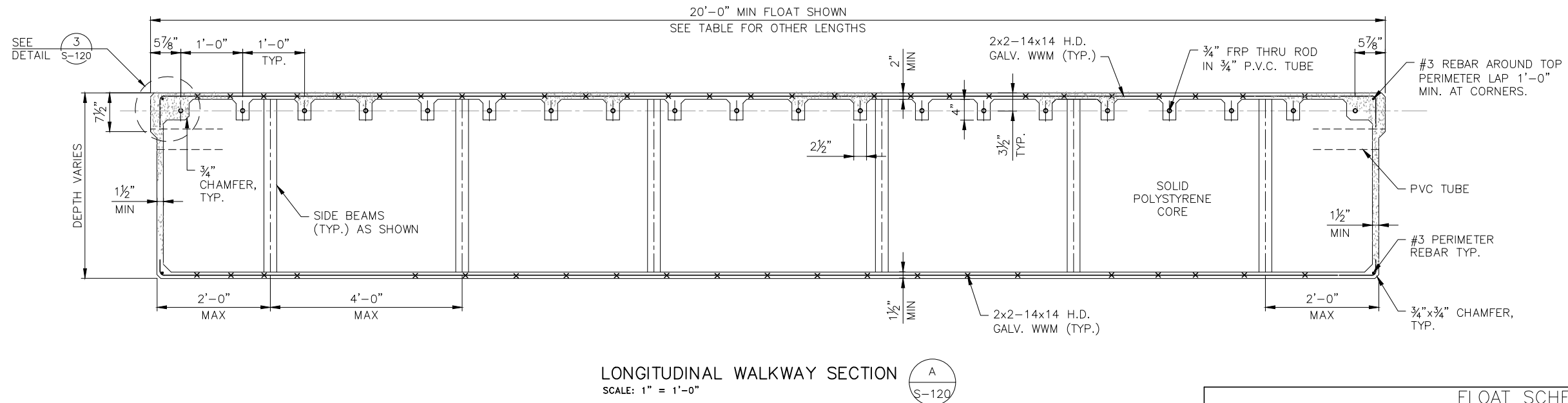

LONGITUDINAL WALKWAY SECTION A
SCALE: 1" = 1'-0"

FLOAT SCHEDULE					
FLOAT TYPE	FINGER	ACCESSIBLE FINGER	END FINGER	MARGINAL WALKWAY	MAIN WALKWAY
CONCRETE FLOAT LENGTH	25'-46'	25'-46'	VARIES	20'-0"	20'-0"
NOMINAL FINGER WIDTH	4'	6'	8'	10'	8'
MINIMUM CONCRETE FLOAT WIDTH	3'-7"	5'-7"	7'-2"	9'-2"	7'-2"
MINIMUM WALKER SIZES	3"x6" IN 3"x6" OUT	3"x6" IN 3"x6" OUT	3"x8" IN 3"x8" OUT	3"x10" IN 3"x10" OUT	3"x10" IN 3"x10" OUT
WOODEN RUB STRIP	2"x8"	2"x10"	2"x10"	2"x12"	2"x12"

- NOTES:
- GENERAL CONCEPT DETAILS SHOWN.
 - CONTRACTOR TO SUBMIT SHOP DRAWING AND FLOATATION CALCULATIONS FOR RECTANGLE FLOATS. ALTERNATE TO RECTANGLE FLOAT MAY BE CONSIDERED AS AN ALTERNATE DESIGN WHICH IS TO BE SUBMITTED FOR APPROVAL.
 - SEE TECHNICAL SPECIFICATIONS AND BASIS OF DESIGN FOR STABLE FREEBOARD UNDER LIVE LOADING.
 - MINIMUM FLOAT LENGTH 20 FEET SHALL HAVE A MINIMUM OF 6 SIDE BEAMS.
 - SIDE BEAMS ARE TO BE PLACED ON ALL 4 SIDES OF FLOAT. LAYOUT TO BE SHOWN ON SHOP DRAWINGS AND IS SUBJECT TO ENGINEERS APPROVAL.
 - PROVIDE DOUBLE STAINLESS STEEL STRAP WITH WATER LINES ON SAME SIDE WHEN SEWER LINE IS PRESENT. OTHERWISE, USE ONLY SINGLE STRAPS POSITION 3" LINE TO ALLOW REMOVAL OF 2" LINE WITHOUT REMOVING 3".
 - WALERS AND RUB STRIPS TO BE COMPOSED OF TIMBER OR APPROVED EQUIVALENT MATERIAL.

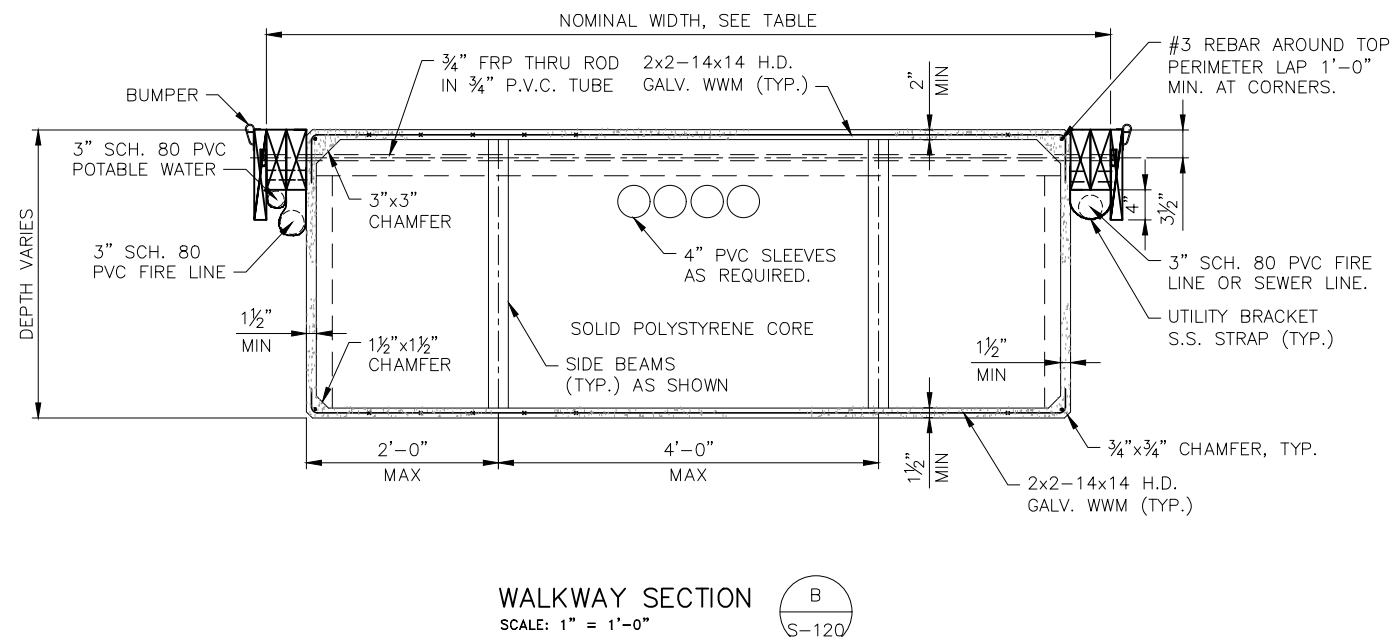

WALKWAY SECTION B
SCALE: 1" = 1'-0"

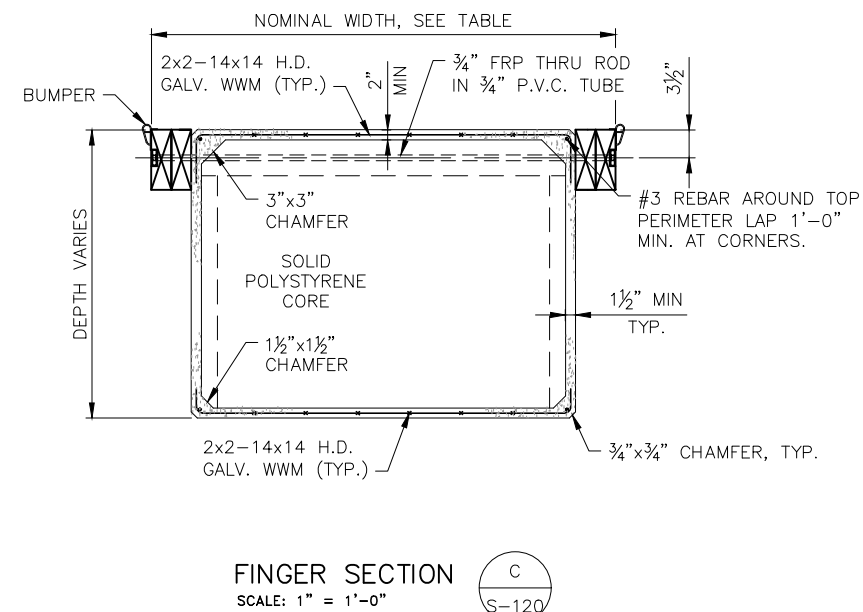

FINGER SECTION C
SCALE: 1" = 1'-0"

PLOTTED BY: NIEL FORTEZ PLOT DATE: 05/10/2023 11:02:28 AM

DRAFT 90% Submittal

DATE	DESCRIPTION	MARK	REVISION	APPROVAL
05-12-2023	50% PROGRESS SUBMITTAL	JMC		
03-27-2023	60% PROGRESS SUBMITTAL	JMC		
06-03-2022	30% PROGRESS SUBMITTAL	JMC		

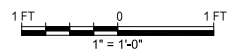

PROJECT MANAGER: _____ DATE _____	DEPICTION OF MONUMENTS: _____ DATE _____	SUBMITTED: _____ DATE _____	DESIGN: JRVS	HORIZ.: AS SHOWN
SURVEY PARTY CHIEF: _____ DATE _____	WATERSHED REVIEW: _____ DATE _____	SUPERVISING CIVIL ENGINEER: _____ DATE _____	DRAWN: NIF	VERT.: _____
		APPROVED: _____ DATE _____	CHECK: JMC	BOOK: _____
		CITY ENGINEER: _____ DATE _____	AS BUILT: _____	DATE: 6/3/22



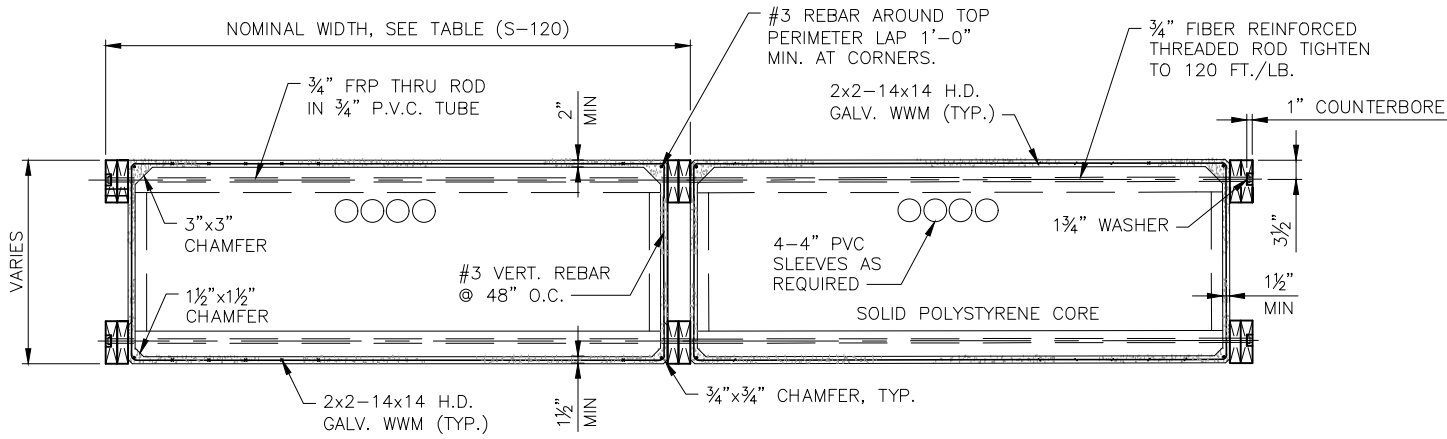

DOUBLE FLOAT SECTION A
SCALE: 3/4" = 1'-0"

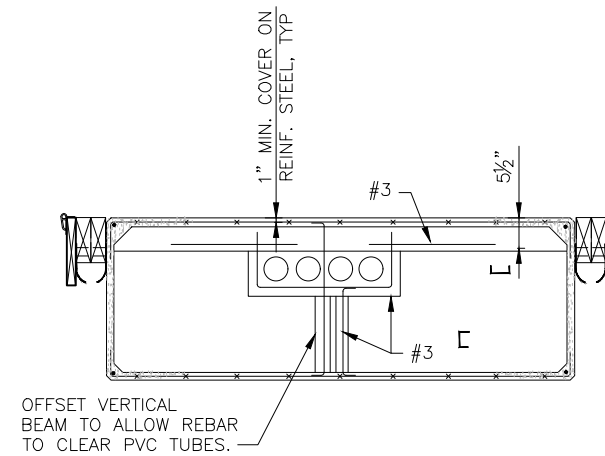

NOTE: SEE WALKWAY SECTION FOR ADDITIONAL INFORMATION

WALKWAY END SECTION B
SCALE: 3/4" = 1'-0"

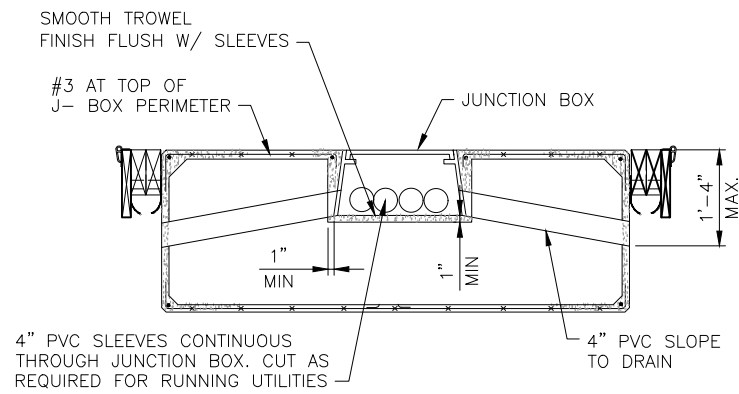

NOTE: STOP BEAMS AT EDGE OF JUNCTION BOX WHERE CONFLICT OCCURS, RODS TO CONTINUE THROUGH

SPLICE BOX SECTION C
SCALE: 3/4" = 1'-0"

NOTES:



1. GENERAL CONCEPT DETAILS SHOWN.
2. CONTRACTOR TO SUBMIT SHOP DRAWING AND FLOATATION CALCULATIONS FOR RECTANGLE FLOATS. ALTERNATE TO RECTANGLE FLOAT MAY BE CONSIDERED AS AN ALTERNATE DESIGN WHICH IS TO BE SUBMITTED FOR APPROVAL.
3. SEE TECHNICAL SPECIFICATIONS AND BASIS OF DESIGN FOR STABLE FREEBOARD UNDER LIVE LOADING.
4. WALERS AND RUB STRIPS TO BE COMPOSED OF TIMBER OR APPROVED EQUIVALENT MATERIAL.

PLOTTED BY: NIEL FORTEZ PLOT DATE: 05/10/2023 11:10:31 AM

DRAFT 90% Submittal

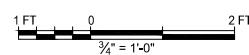
REVISION	MARK	DATE	DESCRIPTION	APPROVAL
C		05-12-2023	50% PROGRESS SUBMITTAL	JMC
B		03-27-2023	60% PROGRESS SUBMITTAL	JMC
A		06-03-2022	30% PROGRESS SUBMITTAL	JMC



PROJECT MANAGER: _____ DATE _____	DEPICTION OF MONUMENTS: _____ DATE _____	SUBMITTED: _____ DATE _____	DESIGN: JRVS	HORIZ.: AS SHOWN	 PHONIC RECREATION & WATERFRONT 1847 CENTER ST., 9TH FL., BERKELEY, CALIFORNIA	 122 22th Street, 12th Floor, Oakland, CA 94612 Tel: 510.808.8972 Fax: 510.808.9752	BERKELEY MARINA DOCK REPLACEMENT (D-E) CITY OF BERKELEY, ALAMEDA COUNTY, CALIFORNIA	PLAN _____
SURVEY PARTY CHIEF _____	WATERSHED REVIEW: _____ DATE _____	SUPERVISING CIVIL ENGINEER _____	DRAWN: NIF	VERT. _____				FILE _____
CITY ENGINEER _____		APPROVED: _____	CHECK: JMC	BOOK _____			FLOAT DETAILS SHEET 2 OF 6	S-121 SHEET 20 OF 51

REVISION	MARK	DATE	DESCRIPTION	APPROVAL
B		05-12-2023	90% PROGRESS SUBMITTAL	JMC
A		03-27-2023	60% PROGRESS SUBMITTAL	JMC

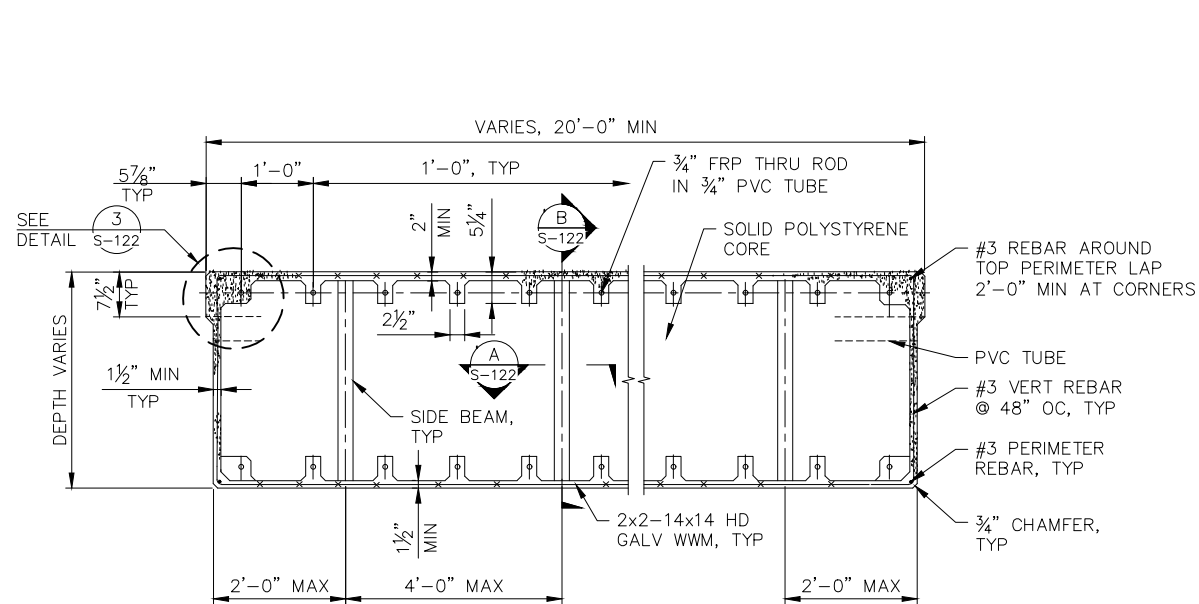

NOTE: INTERNAL CONCRETE SIDE BEAMS ARE TO BE PLACED ON ALL 4 SIDES OF FLOAT. LAYOUT TO BE SHOWN ON SHOP DRAWINGS AND IS SUBJECT TO ENGINEER'S APPROVAL.

FLOAT SECTION
 SCALE: 3/4" = 1'-0"
 S-122 (1)

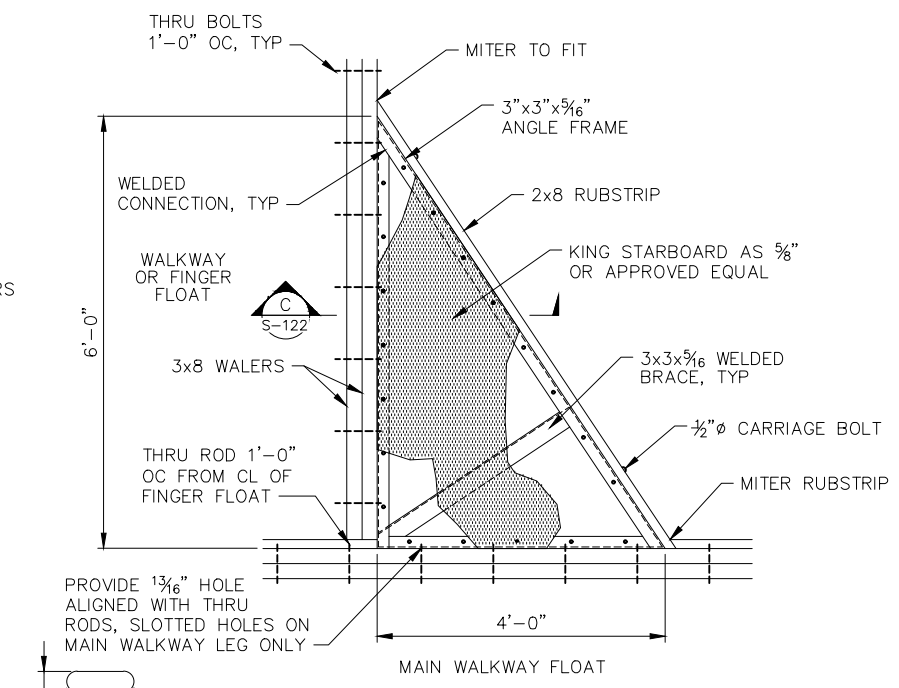
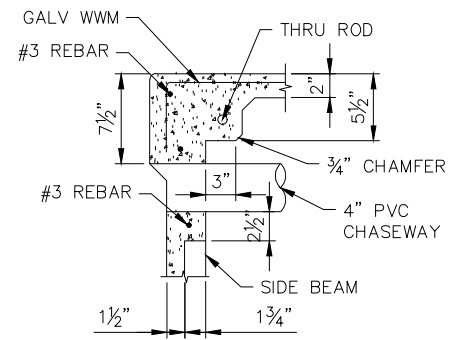
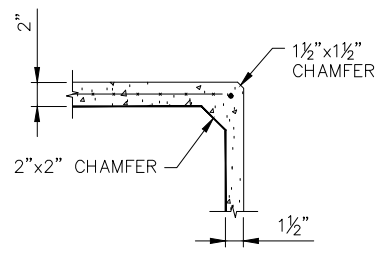

NOTE:
 1. WALERS AND RUB STRIPS TO BE COMPOSED OF TIMBER OR APPROVED EQUIVALENT MATERIAL.

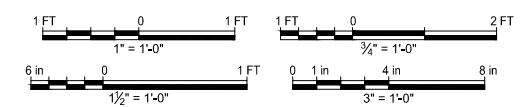
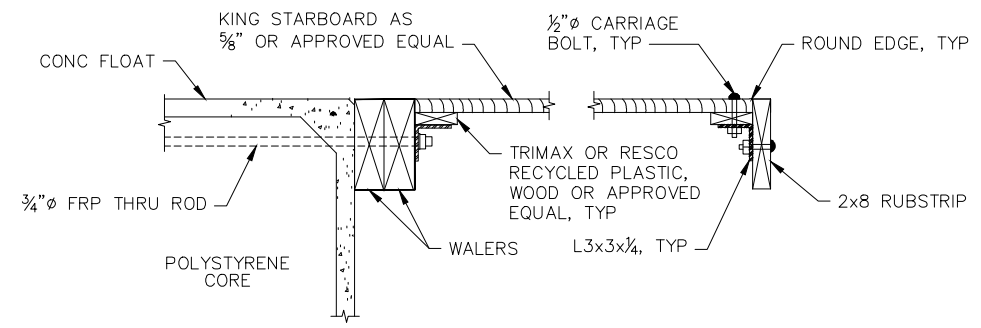
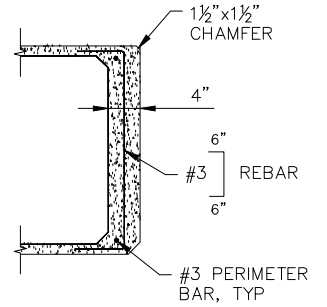
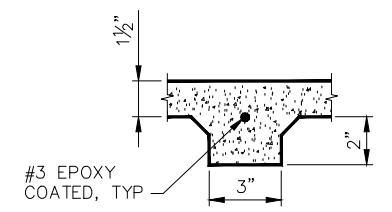

PROJECT MANAGER: _____ DATE _____	DEPICTION OF MONUMENTS: _____ DATE _____	SUBMITTED: _____ DATE _____	DESIGN: JRVS	HORIZ.: AS SHOWN		BERKELEY MARINA DOCK REPLACEMENT (D-E) CITY OF BERKELEY, ALAMEDA COUNTY, CALIFORNIA	PLAN _____
SURVEY PARTY CHIEF: _____ DATE _____	WATERSHED REVIEW: _____ DATE _____	SUPERVISING CIVIL ENGINEER: _____ DATE _____	DRAWN: NIF	VERT.: _____			FILE _____
CITY ENGINEER: _____ DATE _____	APPROVED: _____ DATE _____	CHECK: JMC	BOOK _____	DATE: 8/XX/22			AS BUILT _____

- NOTES:
1. ALL WELDED STEEL BRACKETS ARE TO BE HOT DIPPED GALVANIZED AFTER FABRICATION.
 2. WALERS AND RUB STRIPS TO BE COMPOSED OF TIMBER OR APPROVED EQUIVALENT MATERIAL.
 3. ALTERNATE DESIGN TO SQUARE END OF FINGERS MAY BE CONSIDERED. SUBMIT ALTERNATE DESIGN FOR APPROVAL.

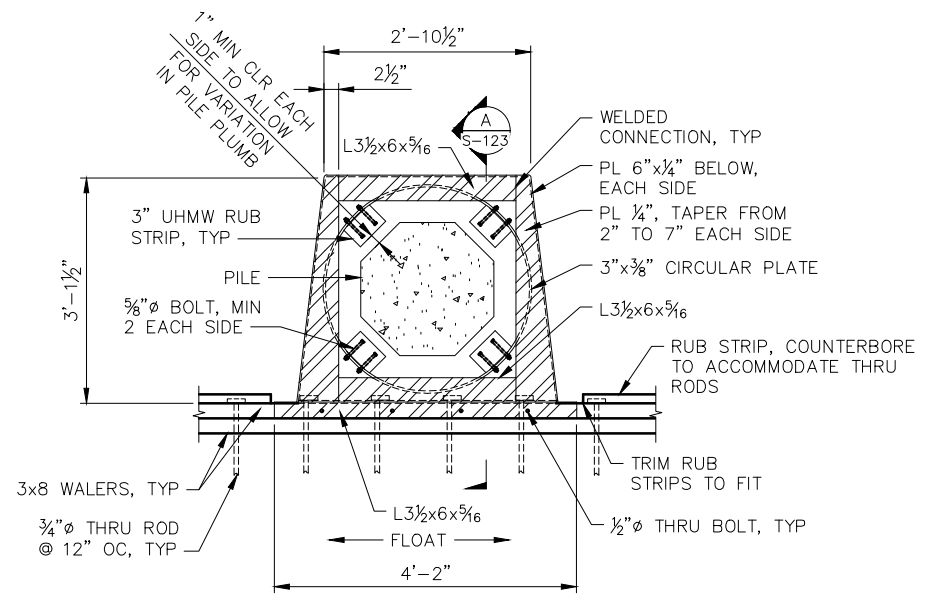

DETAIL - SIDE PILE BRACKET (1)
SCALE: 3/4" = 1'-0"

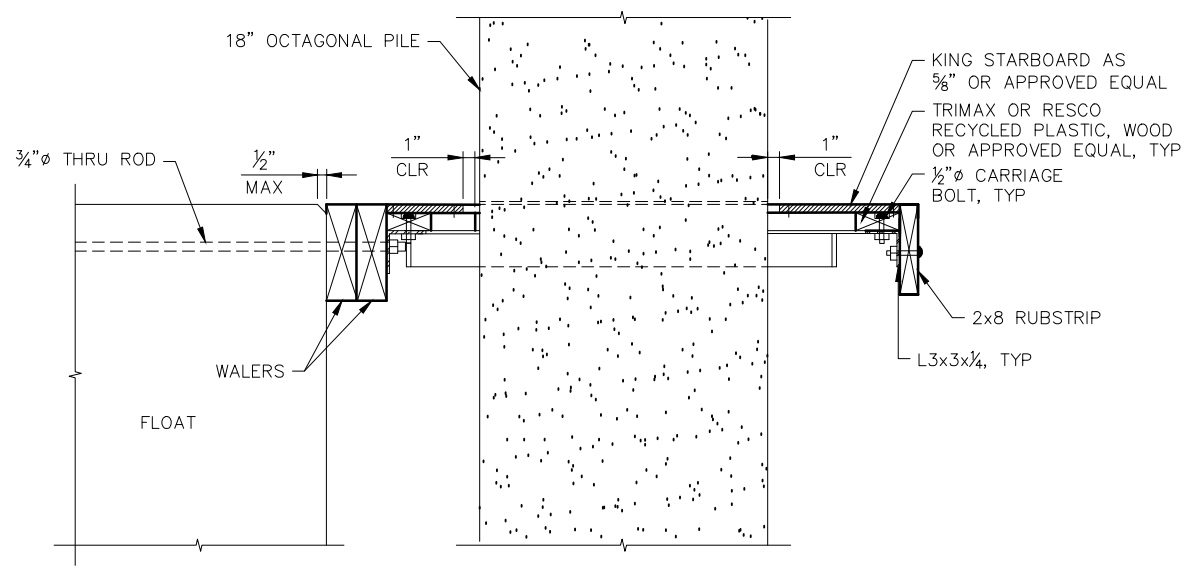

SECTION - SIDE PILE BRACKET (A)
SCALE: 1 1/2" = 1'-0"

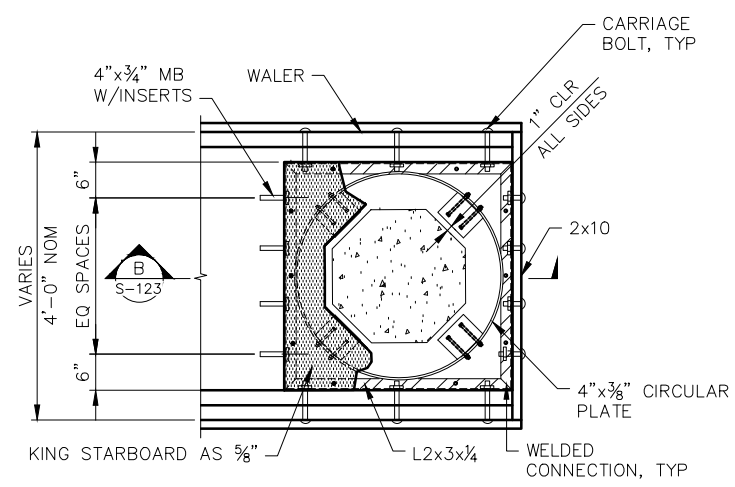

DETAIL - END PILE BRACKET (2)
SCALE: 3/4" = 1'-0"
NOTE: SEE NOTE 3

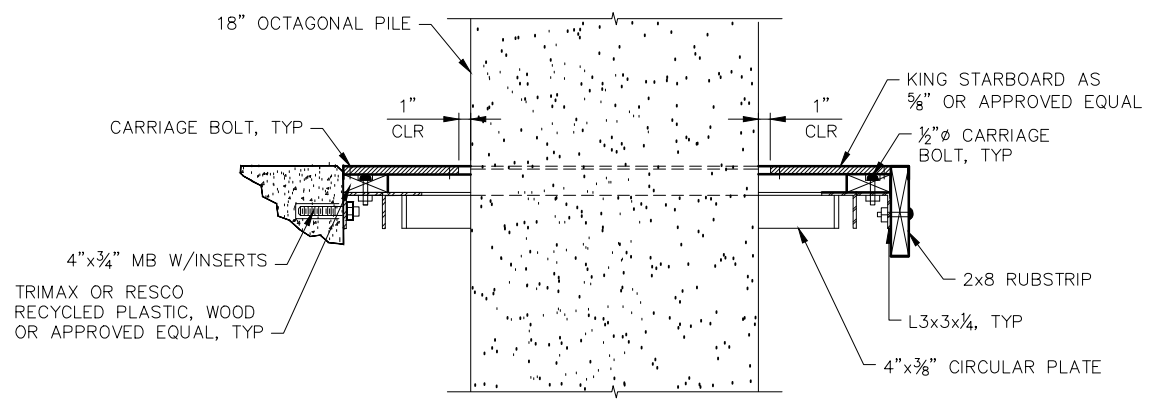

SECTION - END PILE BRACKET (B)
SCALE: 1 1/2" = 1'-0"

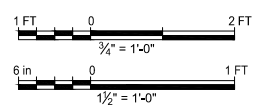

PROJECT MANAGER: _____ DATE _____	DEPICTION OF MONUMENTS: _____ DATE _____	SUBMITTED: _____ DATE _____	DESIGN: <u>JRVS</u>	HORIZ.: <u>AS SHOWN</u>	 PHURS RECREATION & WATERFRONT 1847 CENTER ST., 9TH FL., BERKELEY, CA 94704	 BERKELEY MARINA DOCK REPLACEMENT (D-E) CITY OF BERKELEY, ALAMEDA COUNTY, CALIFORNIA	PLAN _____
SURVEY PARTY CHIEF _____ DATE _____	WATERSHED REVIEW: _____ DATE _____	SUPERVISING CIVIL ENGINEER _____ DATE _____	DRAWN: <u>JMC</u>	VERT.: _____			FILE _____
CITY ENGINEER _____ DATE _____	APPROVED: _____ DATE _____	CHECK: <u>JMC</u>	BOOK _____	DATE: <u>5/XX/22</u>			SHEET 22 OF 51

DRAFT 90% Submittal

REVISION	MARK	DATE	DESCRIPTION	APPROVAL
B		05-12-2023	90% PROGRESS SUBMITTAL	JMC
A		03-27-2023	60% PROGRESS SUBMITTAL	JMC

- NOTES:
1. ALL WELDED STEEL BRACKETS ARE TO BE HOT DIPPED GALVANIZED AFTER FABRICATION.
 2. WALERS AND RUB STRIPS TO BE COMPOSED OF TIMBER OR APPROVED EQUIVALENT MATERIAL.
 3. ALTERNATE DESIGN TO SQUARE END OF FINGERS MAY BE CONSIDERED. SUBMIT ALTERNATE DESIGN FOR APPROVAL.

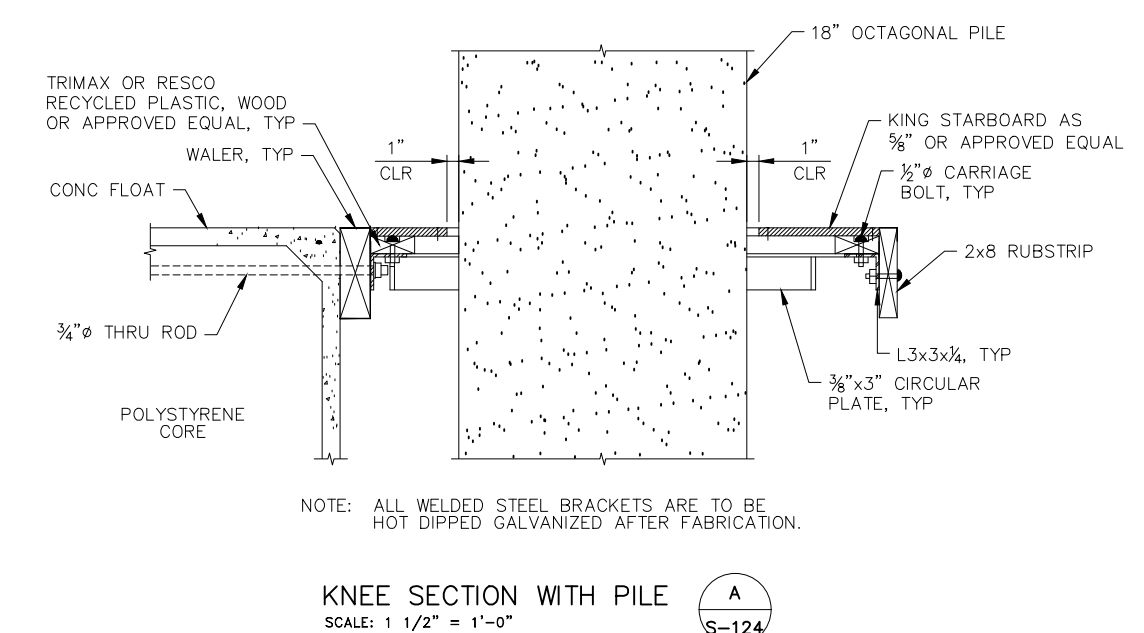
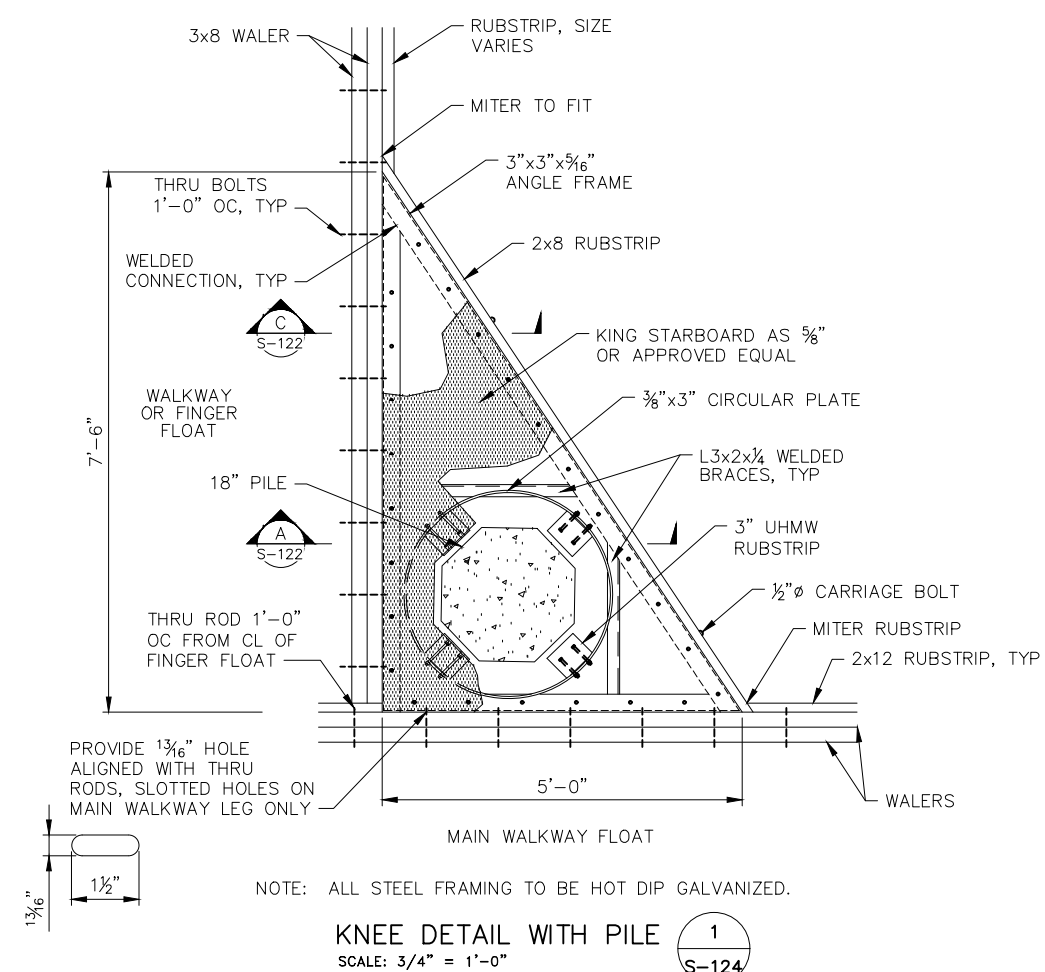

DRAFT 90% Submittal

REVISION	MARK	DATE	DESCRIPTION	JMC	JMC	APPROVAL
B		05-12-2023	90% PROGRESS SUBMITTAL			
A		03-27-2023	60% PROGRESS SUBMITTAL			

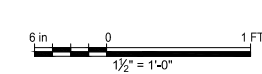

PROJECT MANAGER: _____ DATE _____	DEPICTION OF MONUMENTS: _____ DATE _____	SUBMITTED: _____ DATE _____	DESIGN: JRVS _____	HORIZ.: AS SHOWN			BERKELEY MARINA DOCK REPLACEMENT (D-E) CITY OF BERKELEY, ALAMEDA COUNTY, CALIFORNIA	PLAN _____
SURVEY PARTY CHIEF _____	WATERSHED REVIEW: _____ DATE _____	SUPERVISING CIVIL ENGINEER _____	DRAWN: NIF _____	VERT.: _____				FILE _____
APPROVED: _____ DATE _____	CITY ENGINEER _____	AS BUILT _____	CHECK: JMC _____	BOOK _____				SHEET 23 OF 51

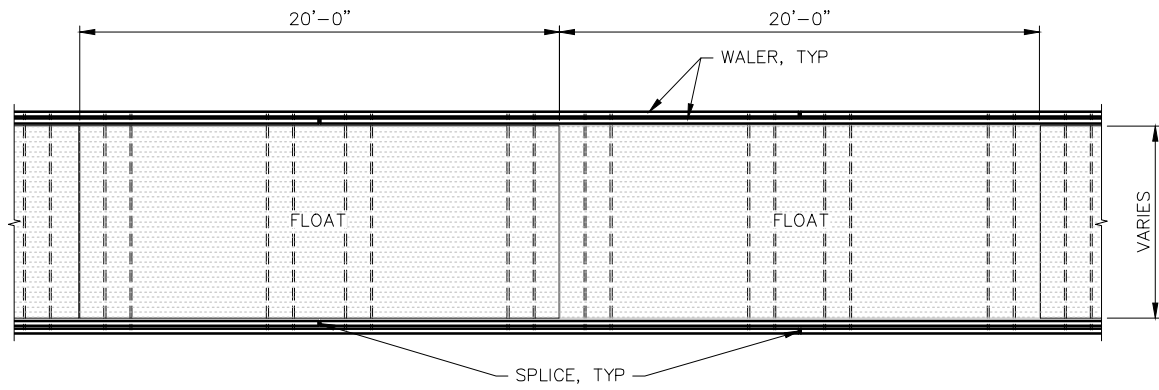

- NOTES:
1. WALER SPLICE AT 1/2 FLOAT LENGTH.
 2. NO TWO WALERS SPLICED AT SAME POINT.
 3. NO SPLICES AT FLOAT JOINTS.
 4. TWO THRU ROD MIN. EACH SIDE OF WALER SPLICE AND FLOAT JOINT.

WALER SPLICE & THRU-ROD DETAIL 1
SCALE: 1/4" = 1'-0"

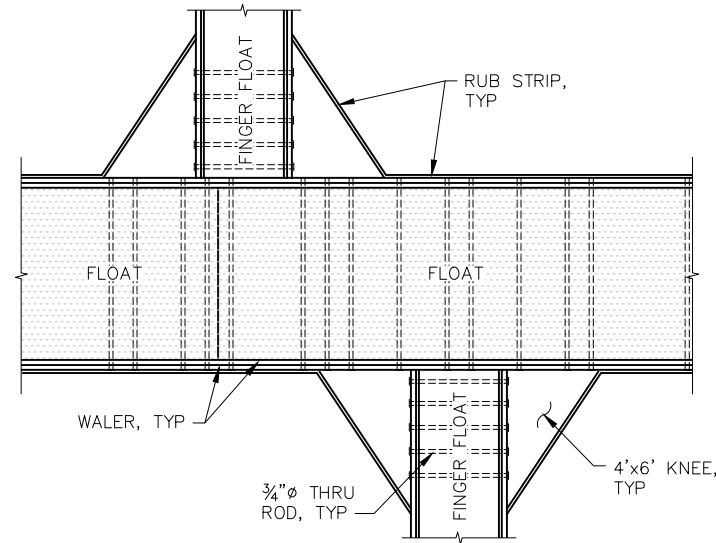

WALKWAY/FINGER CONNECTION 2
SCALE: 1/4" = 1'-0"

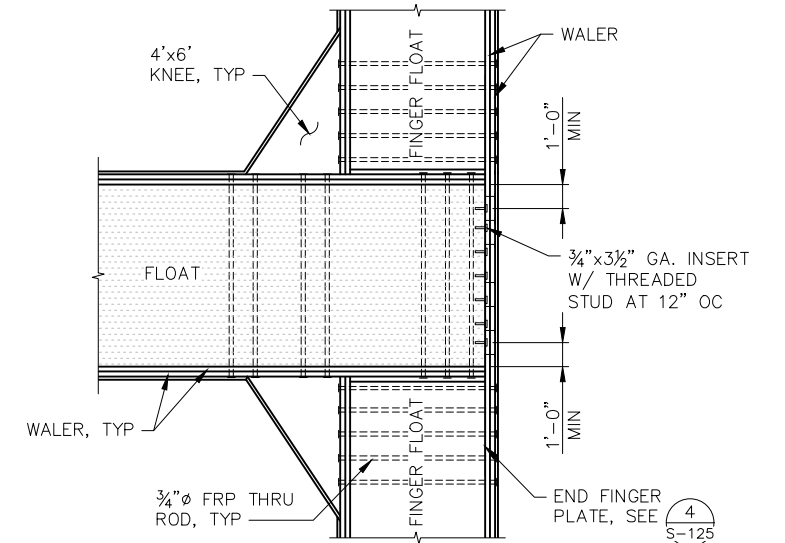

WALKWAY/END FINGER CONNECTION 3
SCALE: 1/4" = 1'-0"

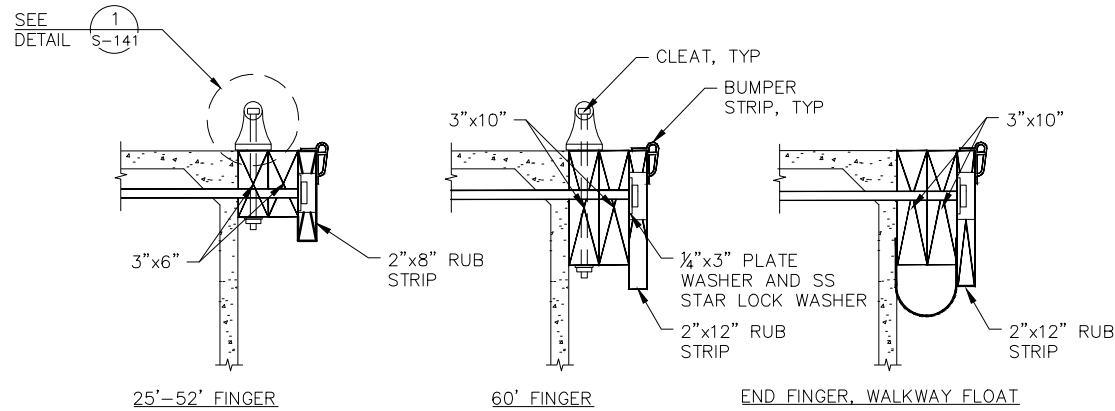

WALER CONNECTION DETAIL 4
SCALE: 1 1/2" = 1'-0"

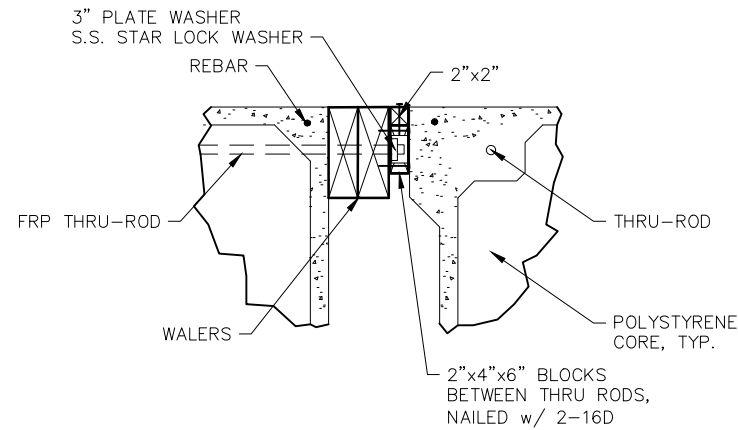

WALKWAY FLOAT CONNECTION DETAIL 5
SCALE: 3" = 1'-0"

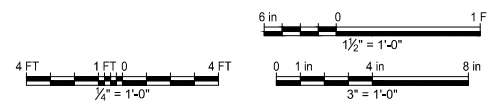

PROJECT MANAGER: _____ DATE _____	DEPICTION OF MONUMENTS: _____ DATE _____	SUBMITTED: _____ DATE _____	DESIGN: <u>JRVS</u>	HORIZ.: <u>AS SHOWN</u>	 COWI <small>300 20th Street, 12th Floor, Berkeley, CA 94712</small> <small>Tel: 510.868.8072 Fax: 510.868.8112</small>	BERKELEY MARINA DOCK REPLACEMENT (D-E)	PLAN _____	
SURVEY PARTY CHIEF _____	WATERSHED REVIEW: _____ DATE _____	SUPERVISING CIVIL ENGINEER _____	DRAWN: <u>NIF</u>	VERT.: _____		CITY OF BERKELEY, ALAMEDA COUNTY, CALIFORNIA	FILE _____	
CITY ENGINEER _____	APPROVED: _____ DATE _____	CHECK: <u>JMC</u>	AS BUILT _____	BOOK _____		DATE: <u>6/3/22</u>	REVISION: _____	
FOR REDUCED PLANS - ORIGINAL SCALE IS IN INCHES						 COWI <small>300 20th Street, 12th Floor, Berkeley, CA 94712</small> <small>Tel: 510.868.8072 Fax: 510.868.8112</small>	BERKELEY MARINA DOCK REPLACEMENT (D-E) CITY OF BERKELEY, ALAMEDA COUNTY, CALIFORNIA FLOAT DETAILS SHEET 6 OF 6	S-125 SHEET 24 OF 51

DRAFT 90% Submittal

PLOTTED BY: NIEL FORTEZ PLOT DATE: 5/12/2023 11:10:40 AM

REVISION	MARK	DATE	DESCRIPTION	APPROVAL
C		05-12-2023	50% PROGRESS SUBMITTAL	JMC
B		03-27-2023	60% PROGRESS SUBMITTAL	JMC
A		06-03-2022	30% PROGRESS SUBMITTAL	JMC

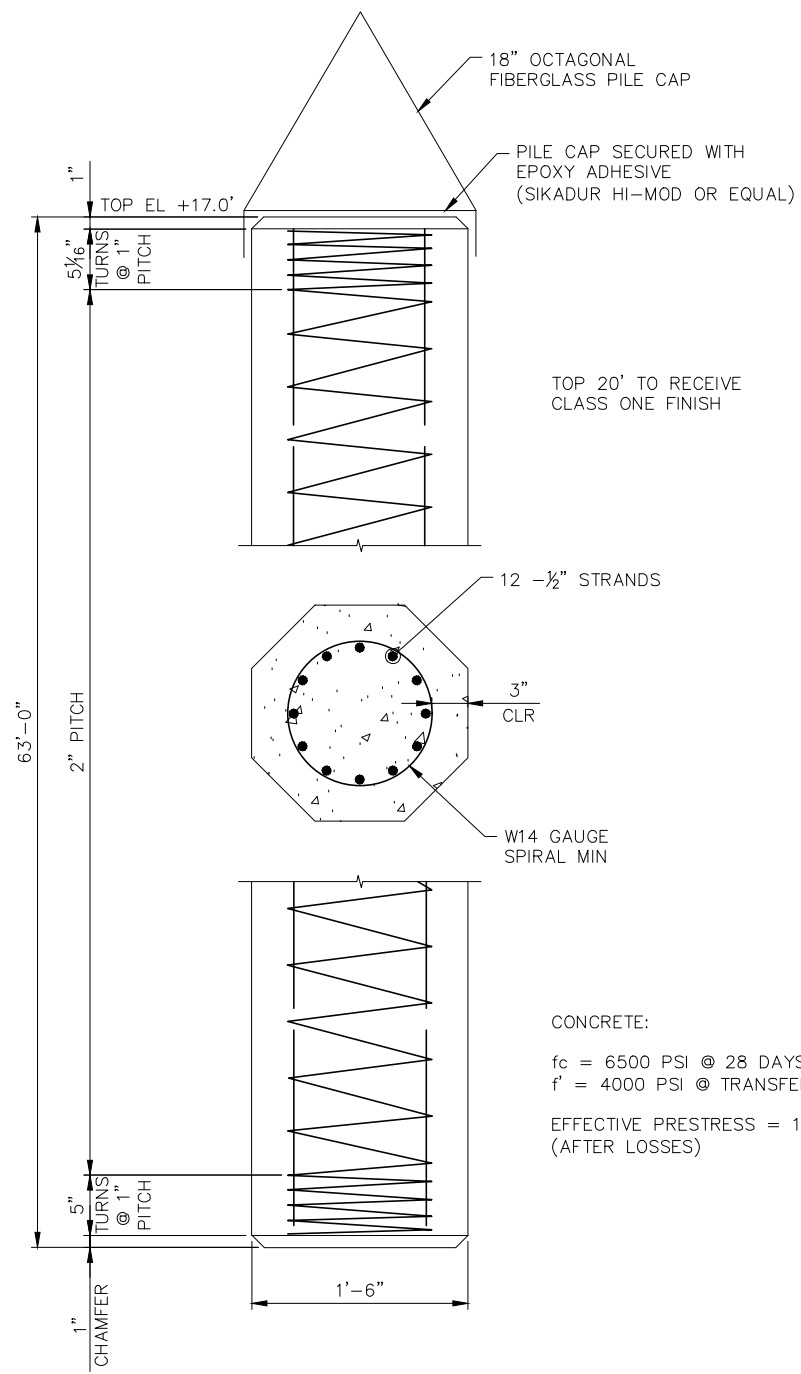

CONCRETE:
 $f_c = 6500 \text{ PSI @ 28 DAYS}$
 $f'_t = 4000 \text{ PSI @ TRANSFER}$
 EFFECTIVE PRESTRESS = 1055 PSI
 (AFTER LOSSES)

GUIDE PILE 18"
 SCALE: 1 1/2" = 1'-0"



NOTES:

1. CONTRACTOR TO SUBMIT PILE CALCULATIONS AND SHOP DRAWINGS FOR REVIEW AND APPROVAL.
2. SEE TECHNICAL SPECIFICATIONS AND BASIS OF DESIGN FOR ADDITIONAL INFORMATION.
3. CONTRACTOR TO DETERMINE FINAL PILE LOCATIONS ON PLAN.

DRAFT 90% Submittal

REVISION	MARK	DATE	DESCRIPTION	APPROVAL
C		05-12-2023	50% PROGRESS SUBMITTAL	JMC
B		03-27-2023	60% PROGRESS SUBMITTAL	JMC
A		06-03-2022	30% PROGRESS SUBMITTAL	JMC

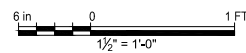

PROJECT MANAGER:	DATE	DEPICTION OF MONUMENTS:	DATE
SURVEY PARTY CHIEF:		WATERSHED REVIEW:	DATE

SUBMITTED:	DATE	DESIGN	JRVS	HORIZ.	AS SHOWN
SUPERVISING CIVIL ENGINEER	R.C.E.	DRAWN	NIF	VERT.	
APPROVED:	DATE	CHECK	JMC	BOOK	
CITY ENGINEER	R.C.E.	AS BUILT		DATE	6/3/22

PHONS RECREATION & WATERFRONT	1847 CENTER ST., 9TH FL., BERKELEY, CALIFORNIA
-------------------------------	--

PHONS RECREATION & WATERFRONT	1847 CENTER ST., 9TH FL., BERKELEY, CALIFORNIA
-------------------------------	--



BERKELEY MARINA DOCK REPLACEMENT (D-E)
 CITY OF BERKELEY, ALAMEDA COUNTY, CALIFORNIA
GUIDE PILE DETAILS

PLAN
 FILE
S-130
 SHEET 25 OF 51

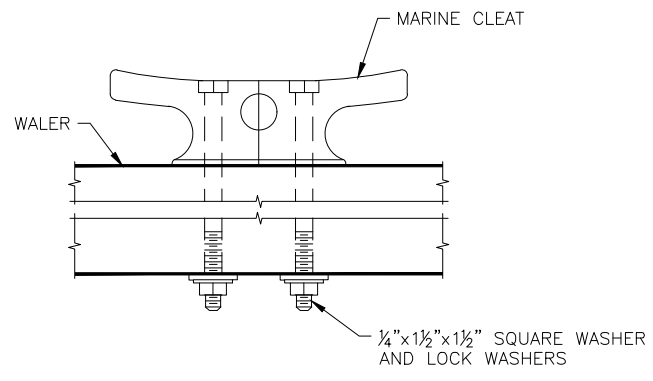

NOTE: FOR TABLE SIZE, LOCATION AND BOLT DIAMETER, SEE TABLE I

CLEAT DETAIL (1)
SCALE: 3" = 1'-0"
S-141

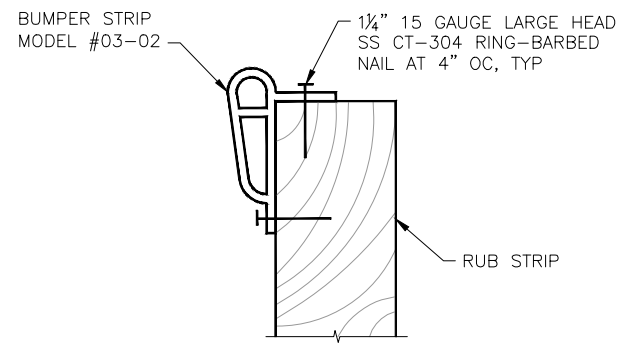

BUMPER STRIP (2)
SCALE: 6" = 1'-0"
S-141

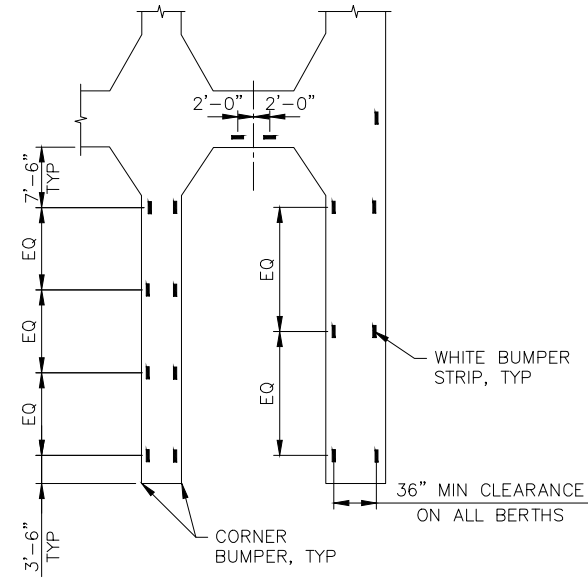

BERTH SIZE	CLEAT SIZE	CLEAT TYPE	BOLT SIZE	TOTAL PER SLIDE
UP TO 40 FT	10"	HEAVY SHIP 504H	1/2"	3
41 FT - 60 FT	12"	HEAVY SHIP 504H	5/8"	4

NOTE: PROVIDE REINFORCED MOORING ATTACHMENTS AT FLOATING HOME LOCATIONS AS NEEDED TO ACCOMMODATE SPECIFIED LOAD.

CLEAT LAYOUT (3)
NOT TO SCALE
S-141

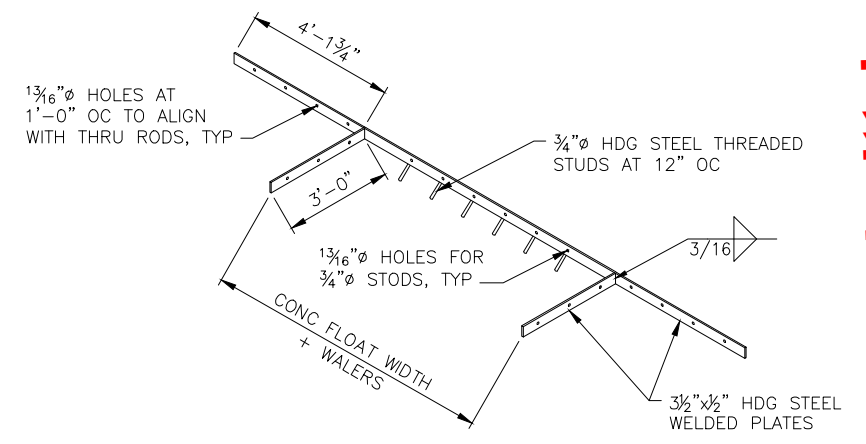

NOTE: PROVIDE REINFORCED CONNECTIONS AT FLOATING HOME LOCATIONS AS NEEDED TO ACCOMMODATE SPECIFIED LOADS HOT DIP GALVANIZE AFTER WELDING.

END FINGER PLATE (4)
SCALE: 3/8" = 1'-0"
S-141

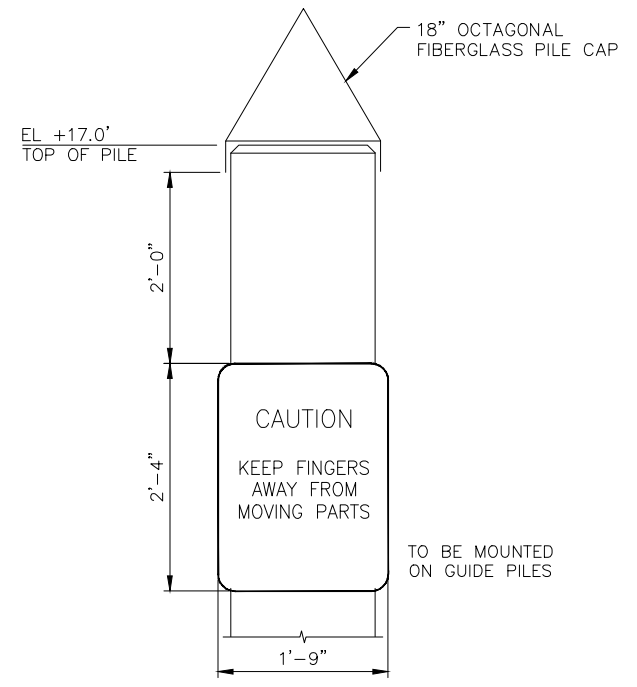

WARNING SIGN (6)
SCALE: 1" = 1'-0"
S-141



20955HM
SIZE: 6" x 6"

NOTE: PROVIDE SYMBOL ON DOCK BOX AT ACCESSIBLE BERTHS.

ACCESSIBLE SYMBOL (5)
SCALE: 3" = 1'-0"
S-141

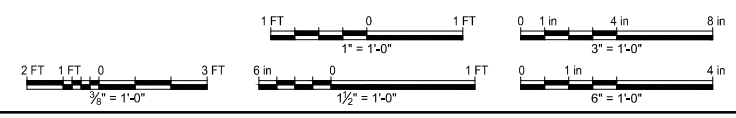

PROJECT MANAGER: _____ DATE _____	DEPICTION OF MONUMENTS: _____ DATE _____	SUBMITTED: _____ DATE _____	DESIGN: <u>JRVS</u>	HORIZ.: <u>AS SHOWN</u>			BERKELEY MARINA DOCK REPLACEMENT (D-E) CITY OF BERKELEY, ALAMEDA COUNTY, CALIFORNIA ACCESSORY DETAILS SHEET 1 OF 2	PLAN _____	
SURVEY PARTY CHIEF: _____ DATE _____	WATERSHED REVIEW: _____ DATE _____	SUPERVISING CIVIL ENGINEER: _____ DATE _____	DRAWN: <u>NIF</u>	VERT.: _____				FILE _____	
CITY ENGINEER: _____ DATE _____	APPROVED: _____ DATE _____	CHECK: <u>JMC</u>	BOOK _____	DATE: <u>6/3/22</u>				AS BUILT _____	REVISION: _____
FOR REDUCED PLANS - ORIGINAL SCALE IS IN INCHES						SHEET 26 OF 51 S-141		90% PROGRESS SUBMITTAL 60% PROGRESS SUBMITTAL 05-12-2023 03-27-2023	APPROVAL JMC JMC

DRAFT 90% Submittal

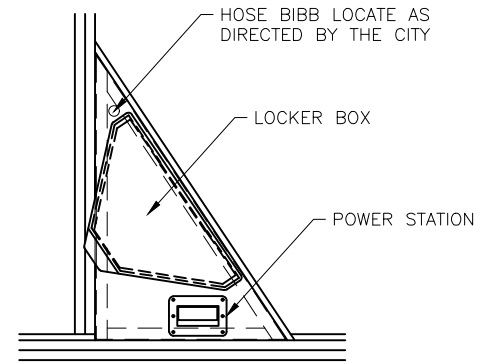

4'x6' KNEE WITH LOCKER BOX

KNEE LAYOUT PLAN
SCALE: 1/2" = 1'-0"

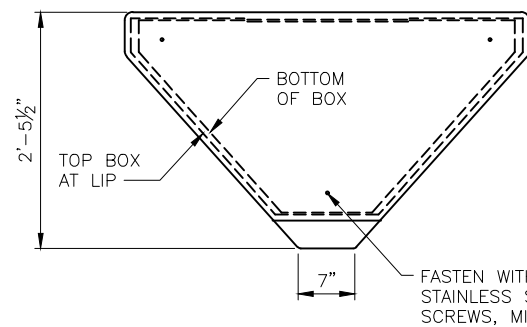
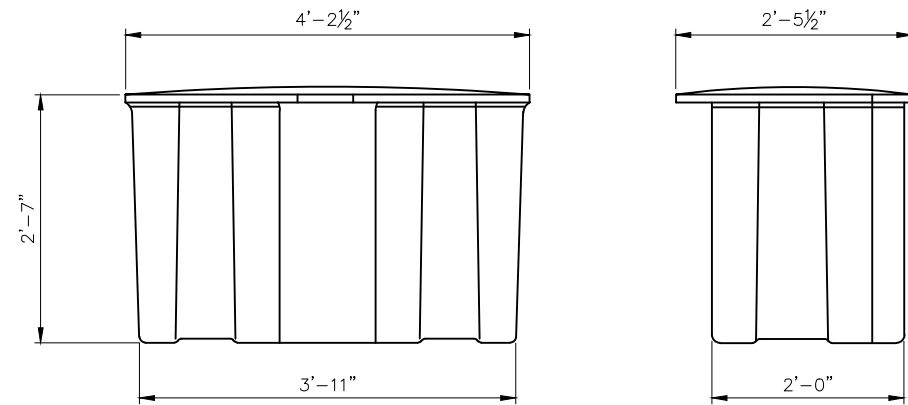

FIBERGLASS LOCKER BOX WITHOUT POWER CENTER (AS SPECIFIED)

#14 X 2" F.H. S.S. SCREW @ S.S. FENDER WASHER

NO DRAIN HOLES IN LOCKER BOXES

FASTEN WITH (3)-3/8" STAINLESS STEEL LAG SCREWS, MINIMUM

LOCKER BOX
SCALE: 1" = 1'-0"

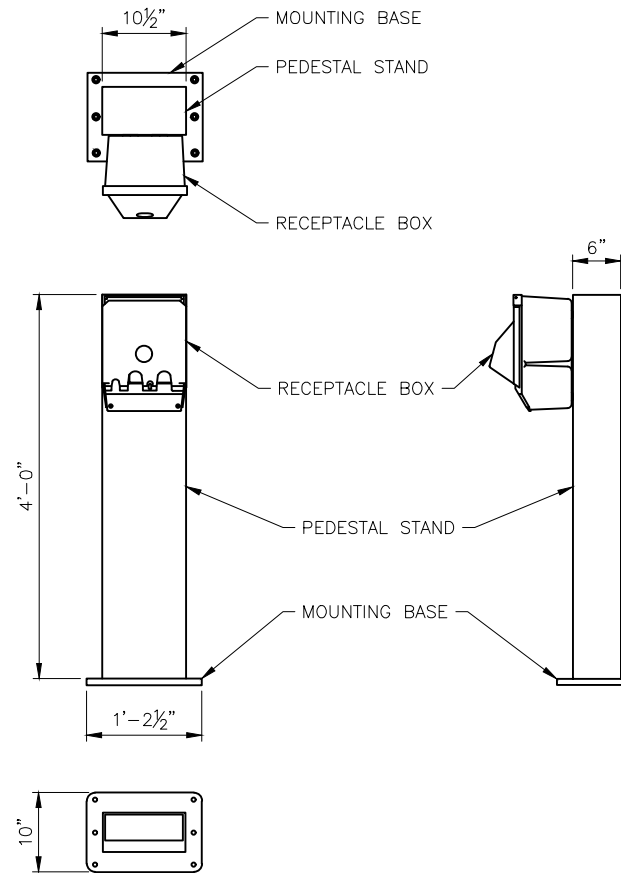

NOTE: NEWPORT TYPE POWER PEDESTAL: ALL LIGHTS AT PEDESTAL SHALL BE CONTROLLED BY PHOTOCELL AT POWER CENTER.
FOR ADDITIONAL INFORMATION, SEE E201 TO E203.

NEWPORT TYPE PEDESTAL
SCALE: 1" = 1'-0"

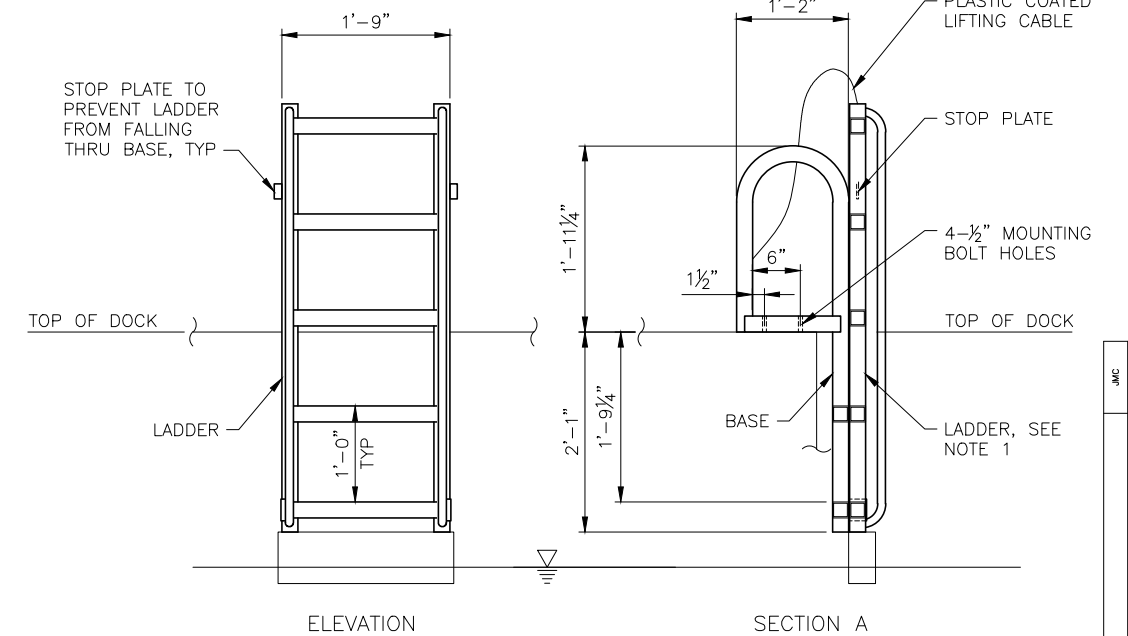
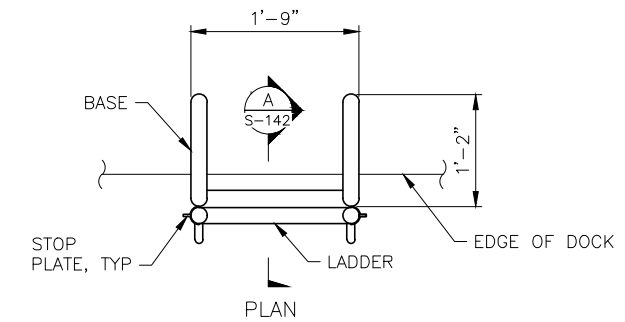

FLOAT FOOT STEP LADDER
SCALE: 1" = 1'-0"

NOTE:
1. FLOAT FOOT STEP LADDER TO BE PROVIDED BY ATLANTIC ALUMINUM & MARINE PRODUCTS OR APPROVED EQUAL BY CITY PROJECT MANAGER

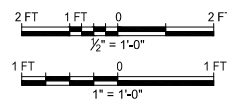

PROJECT MANAGER: _____ DATE _____	DEPICTION OF MONUMENTS: _____ DATE _____	SUBMITTED: _____ DATE _____	DESIGN: <u>JRVS</u>	HORIZ.: <u>AS SHOWN</u>	 COWI 111 12th Street, 11th Floor, Berkeley, CA 94712 Tel: 510.868.8972 Fax: 510.868.9755 www.cowi.com	BERKELEY MARINA DOCK REPLACEMENT (D-E) CITY OF BERKELEY, ALAMEDA COUNTY, CALIFORNIA	PLAN _____
SURVEY PARTY CHIEF _____	SUPERVISING CIVIL ENGINEER _____	DATE _____	DRAWN: <u>NIF</u>	VERT.: _____		FILE _____	
WATERSHED REVIEW: _____ DATE _____	APPROVED: _____ DATE _____	DATE _____	CHECK: <u>JMC</u>	BOOK _____		REVISION _____	
FOR REDUCED PLANS - ORIGINAL SCALE IS IN INCHES		CITY ENGINEER _____	AS BUILT _____	DATE: <u>6/3/22</u>		ACCESSORY DETAILS SHEET 2 OF 2	S-142 SHEET 27 OF 51

DRAFT 90% Submittal

REVISION	MARK	DATE	DESCRIPTION	APPROVAL
C		05-12-2023	50% PROGRESS SUBMITTAL	JMC
B		03-27-2023	60% PROGRESS SUBMITTAL	JMC
A		06-03-2022	30% PROGRESS SUBMITTAL	JMC

PLOTTED BY: NIEL FOREZ PLOT DATE: 5/10/2023 11:10:47 AM

GENERAL NOTES

- ALL WORK SHALL BE IN ACCORDANCE WITH THE CURRENT NATIONAL ELECTRICAL CODE (NEC), CALIFORNIA BUILDING CODE (CBC).
- EXAMINE ALL DRAWINGS AND FIELD VERIFY (E) ELECTRICAL CONDITIONS INCLUDING VOLTAGES, EXISTING CIRCUITS, AND EXACT ROUTING OF ALL CONDUITS AND CONDITIONS IN AND AROUND CONDUIT RUNS.
- COORDINATE ALL WORK WITH OTHER TRADES TO AVOID INTERFERENCE INCLUDING OTHER ONGOING CONSTRUCTION.
- REPORT ANY DISCREPANCY TO ARCHITECT/ENGINEER PRIOR TO ANY WORK.
- CONTRACTOR SHALL BE RESPONSIBLE FOR PROTECTION AND PROVIDE REPAIR OF ADJACENT EXISTING SURFACES, AREAS AND PROPERTY THAT MAY BE DAMAGED AS A RESULT OF NEW WORK.
- COORDINATE ALL SHUTDOWNS WITH THE OWNER REPRESENTATIVE AND PG&E SERVICES.
- THE DRAWINGS ARE DIAGRAMMATIC AND SHALL NOT BE SCALED TO DETERMINE EXACT LOCATION OF ELECTRICAL EQUIPMENT. THE CONTRACTOR SHALL BE RESPONSIBLE FOR INSTALLING CONDUITS, FITTINGS AND JUNCTION BOXES TO CONFORM WITH FIELD CONDITIONS.
- UNLESS OTHERWISE NOTED, USE 3/4" MINIMUM CONDUIT.
- UNLESS OTHERWISE NOTED, USE MINIMUM #12 AWG WIRE.
- CONTRACTOR SHALL TEST ALL ELECTRICAL EQUIPMENT PER LATEST VERSION OF NETA AND NETA CERTIFIED 3RD PARTY.
- KEEP JOBSITE IN AN ORDERLY CONDITION AND AT PROJECT COMPLETION, REMOVE ALL WASTE, AND LEAVE THE JOBSITE IN A CONDITION ACCEPTABLE TO THE CONSTRUCTION INSPECTOR.
- COORDINATE WITH THE CITY OF BERKELEY FOR ALLOWING ACCESS TO CHARTERED VESSELS AT DOCK "K" DURING CONSTRUCTION.
- EQUIPMENT DIMENSIONS SHOWN ARE APPROXIMATE AND MAY VARY DEPENDING ON MANUFACTURER AND FINAL APPROVED SHOP DRAWINGS CONTRACTOR SHALL VERIFY NEW EQUIPMENT DIMENSIONS AND SIZES FOR PROPER INSTALLATION.
- PROVIDE PORTABLE GENERATOR POWER SERVING UNAFFECTED DOCKS AND RESTROOM AMID THE POWER SHUTDOWN BY PG&E SERVICE.
- ALL WIRE SPLICING ON THE DOCK AND UNDERNEATH THE GANGWAY SHALL BE SUBMERSIBLE TYPE.
- ALL SUPPORT HARDWARE SHALL BE STAINLESS STEEL UNLESS OTHERWISE NOTED.

ABBREVIATIONS

ABBREV.	DESCRIPTION	ABBREV.	DESCRIPTION
&	AND	JBOX	JUNCTION BOX
A, AMP	AMPERES	(N)	NEW
ABB'S	ABBREVIATIONS	N	NEUTRAL
AFF	ABOVE FINISHED FLOOR	NTS	NOT TO SCALE
AF	AMP FRAME	N/A	NOT APPLICABLE
AT	AMP TRIP		
C	CONDUIT	PC	POWER CENTER
CB	CIRCUIT BREAKER	PNL	PANELBOARD
CKT	CIRCUIT	PH, ∅	PHASE
DEMO	DEMOLISH	(R)	RELOCATE
DWG(S)	DRAWING(S)	RCPT	RECEPTACLE
(E)	EXISTING	RUM	REMOTE UTILITY METER (MARINESYNC OR APPROVED EQUAL)
EA	EACH	SS	STAINLESS STEEL
ELEC	ELECTRICAL	TELE	TELECOMMUNICATION
EM	EMERGENCY	(TYP)	TYPICAL
EQPT	EQUIPMENT	UON	UNLESS OTHERWISE NOTED
FIXTURE	FIXTURE	V	VOLT
FUT	FUTURE	W	WATT(S)
G/GND	GROUND	WP	WATERPROOF
GFI	GROUND FAULT INTERRUPTER		
GRS	GALVANIZED RIGID STEEL		

ELECTRICAL LEGEND

SYMBOL	DESCRIPTION
	BOLLARD LIGHTING FIXTURE
	RAIL LIGHTING FIXTURE
	KEYNOTE NUMBER
	DISCONNECT SWITCH, 30A NEMA 3R UON
	STEP DOWN TRANSFORMER
	POWER CENTER SUBSTATION WITH INTEGRATED TRANSFORMER AND PANEL
	EQUIPMENT TO BE DEMOLISH
	CONTINUATION BREAK LINE
	RACEWAY EXPOSED
	RACEWAY (POWER) CONCEALED/UNDERGROUND ROUTING
	RACEWAY (COMM) CONCEALED/UNDERGROUND ROUTING
	NEWPORT POWER PEDESTAL WITH RUM AND PHONE CABLE TV & INTERNET RECEPTACLE CONFIGURATION AS DESCRIBED BELOW: (1) 30A(NEMA L5-30R) + (1) 50A(CS6365)
	LIGHTHOUSE POWER PEDESTAL WITH RUM AND PHONE CABLE TV & INTERNET RECEPTACLE CONFIGURATION AS DESCRIBED BELOW: (1) 30A(NEMA L5-30R) + (1) 50A(CS6365)
	GATE CONTROLLER/CARD READER
	LIGHT FIXTURE TAG (REFER TO LIGHT FIXTURE SCHEDULE) WATTAGE

ELECTRICAL LEGEND (CONTINUED)

SYMBOL	DESCRIPTION
	SWITCHBOARD
	RADIO BASE STATION FOR RUM
	PG&E METER
	GROUND FAULT TRIP PROTECTION
	BREAKER
	TRANSFORMER DELTA-WYE TYPE
	PHOTOCELL SENSOR

DRAFT 90% Submittal

PLOTTED BY: MINH TRAN PLOT DATE: 05/20/23 4:25:18 PM

DATE	DESCRIPTION	REVISION	MARK	APPROVAL
05-12-2023	30% PROGRESS SUBMITTAL	C		
03-23-2023	60% PROGRESS SUBMITTAL	B		
08-03-2022	30% PROGRESS SUBMITTAL	A		



PROJECT MANAGER: _____ DATE _____
 DEPICTION OF MONUMENTS: _____ DATE _____
 SURVEY PARTY CHIEF _____
 WATERSHED REVIEW: _____ DATE _____
 FOR REDUCED PLANS - ORIGINAL SCALE IS IN INCHES

SUBMITTED: _____ DATE _____
 SUPERVISING CIVIL ENGINEER _____
 APPROVED: _____ DATE _____
 CITY ENGINEER _____

DESIGN: _____
 DRAWN: _____
 CHECK: _____
 AS BUILT: _____

HORIZ. NO SCALE _____
 VERT. _____
 BOOK _____
 DATE 05/12/23



BERKELEY MARINA DOCK REPLACEMENT (D-E)
 CITY OF BERKELEY, ALAMEDA COUNTY, CALIFORNIA
 ELECTRICAL LEGEND, ABBREVIATIONS
 AND GENERAL NOTES

PLAN _____
 FILE _____
 E-001
 SHEET 28 OF 51



SHEET NOTES

- REFER TO SHEET E-001 FOR ELECTRICAL LEGEND, ABBREVIATIONS, AND GENERAL NOTES.

PLOTTED BY: MINH TRAN PLOT DATE: 5/20/23 4:25:41 PM

DRAFT 90% Submittal

PROJECT SITE PLAN
 SCALE: 1" = 100'-0"



PROJECT MANAGER: _____ DATE _____
 SURVEY PARTY CHIEF _____
 WATERSHED REVIEW: _____ DATE _____
FOR REDUCED PLANS - ORIGINAL SCALE IS IN INCHES

DEPICTION OF MONUMENTS: _____ DATE _____
 SURVEY PARTY CHIEF _____
 WATERSHED REVIEW: _____ DATE _____

SUBMITTED: _____ DATE _____
 R.C.E. _____
 SUPERVISING CIVIL ENGINEER _____
 EXP. _____
 APPROVED: _____ DATE _____
 R.C.E. _____
 CITY ENGINEER _____
 EXP. _____

DESIGN: JH
 DRAWN: MT
 CHECK: GC
 AS BUILT _____
 DATE: 05/12/23

HORIZ.: 1" = 100'-0"
 VERT.: _____
 BOOK: _____



BERKELEY MARINA DOCK REPLACEMENT (D-E)
 CITY OF BERKELEY, ALAMEDA COUNTY, CALIFORNIA
SITE PLAN
DOCK "D" & "E"

REVISION	MARK	DATE	DESCRIPTION	APPROVAL
C		05-12-2023	90% PROGRESS SUBMITTAL	GC
B		03-23-2023	60% PROGRESS SUBMITTAL	GC
A		08-03-2022	30% PROGRESS SUBMITTAL	GC

PLAN _____
 FILE _____
 E-002
 SHEET 29 OF 51

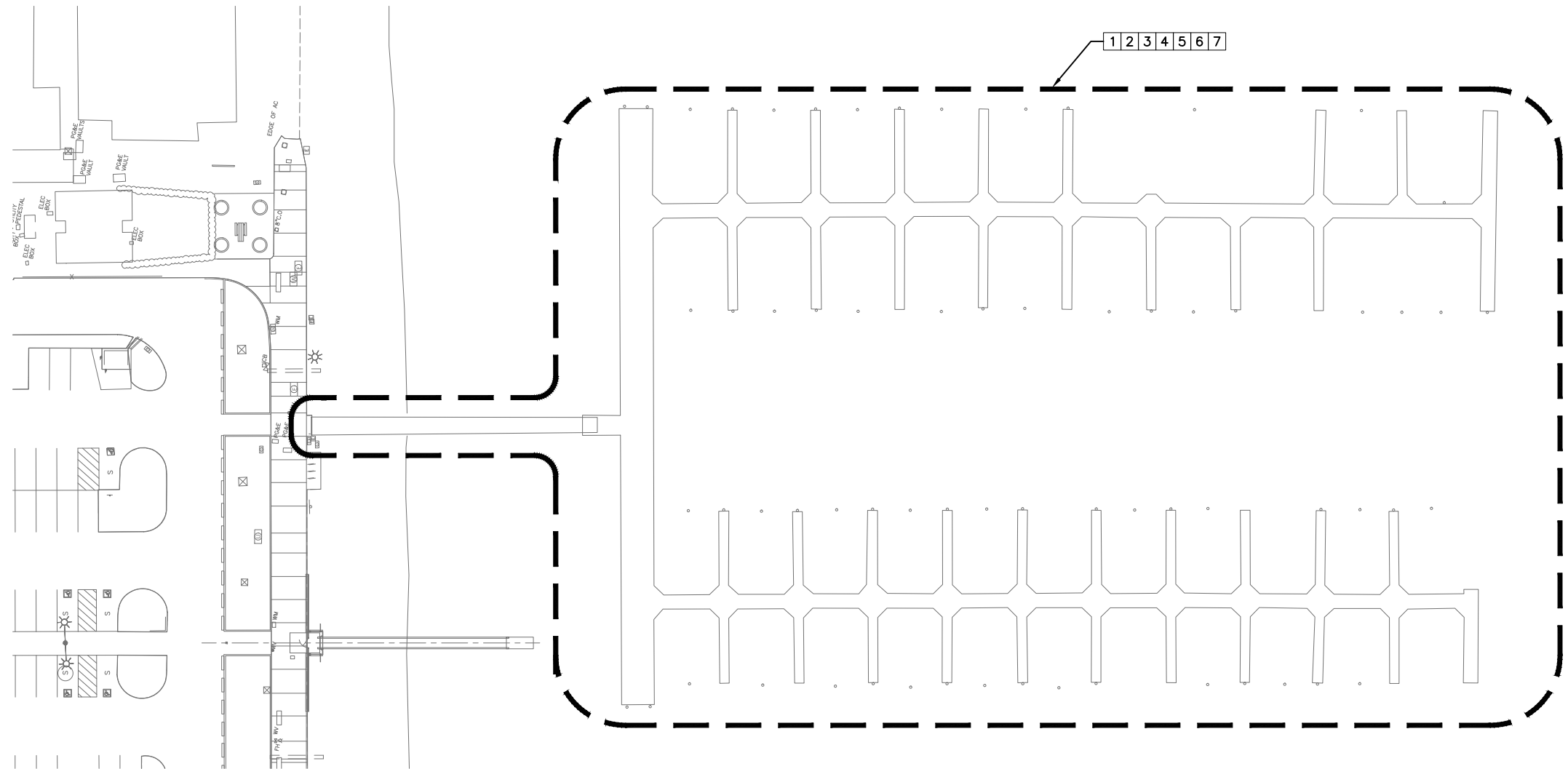

SHEET NOTES

1. REFER TO SHEET E-001 FOR ELECTRICAL LEGEND, ABBREVIATIONS, AND GENERAL NOTES.
2. ALL EQUIPMENT SHOWN ARE (E) UON.
3. MAINTAIN POWER CONTINUITY TO (E) LIGHTING AND OTHER LOADS.
4. CONTRACTOR SHALL BE RESPONSIBLE FOR ALL REPAIRS AND DAMAGED SPACE DUE TO ANY WORK.

KEY NOTES

- 1 DEMOLISH ALL (E) PG&E METERS AND ASSOCIATED RACEWAYS AND CABLES.
- 2 DEMOLISH ALL (E) RECEPTACLE BOXES, ASSOCIATED RACEWAYS AND CABLES, AND THE SUPPORT PLATFORM.
- 3 DEMOLISH ALL (E) DOCK LIGHT FIXTURES AND ASSOCIATED RACEWAYS AND CABLES.
- 4 DEMOLISH ALL (E) POWER PEDESTALS, ASSOCIATED RECEPTACLES, AND PG&E METERS. DEMOLISH ALL ASSOCIATED RACEWAYS AND CABLES.
- 5 DEMOLISH (E) MAIN BREAKER AND ENCLOSURE. DEMOLISH ALL ASSOCIATED RACEWAYS AND CABLES.
- 6 REMOVE AND SALVAGE (E) WIFI ANTENNA.
- 7 DEMOLISH (E) AUTOMATIC GATE OPENER AND ASSOCIATED RACEWAYS AND CABLES.

ELECTRICAL PLAN DEMOLITION WORK – DOCK "D&E"

SCALE: 1" = 30'-0"

1
E-003

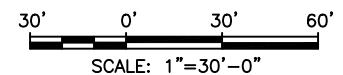

SCALE: 1"=30'-0"

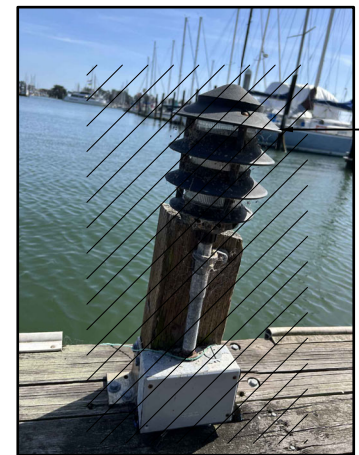

DEMOLITION PHOTO 1

NTS

2
E-003

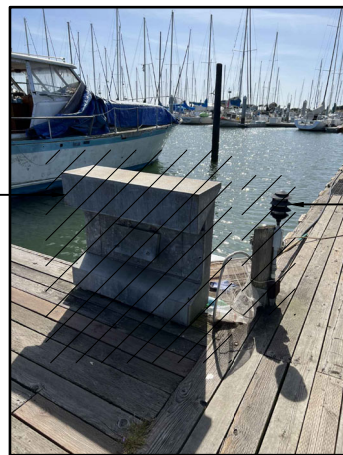

DEMOLITION PHOTO 2

NTS

3
E-003

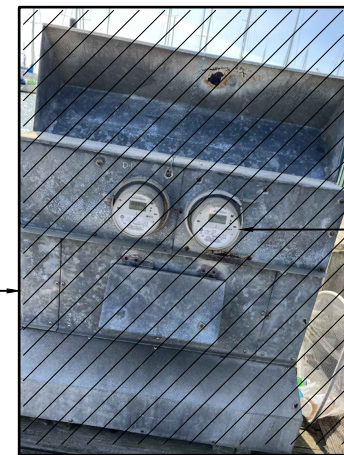

DEMOLITION PHOTO 3

NTS

4
E-003

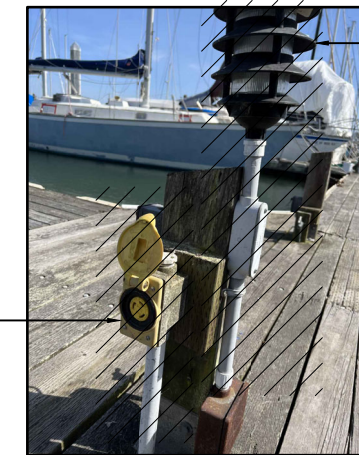

DEMOLITION PHOTO 4

NTS

5
E-003



DEMOLITION PHOTO 5

NTS

6
E-003

DRAFT 90% Submittal

PLOTTED BY: MINH TRAN PLOT DATE: 5/20/23 4:24:01 PM

REVISION	MARK	DATE	DESCRIPTION
C		05-12-2023	90% PROGRESS SUBMITTAL
B		03-23-2023	60% PROGRESS SUBMITTAL
A		08-03-2022	30% PROGRESS SUBMITTAL



PROJECT MANAGER: _____ DATE _____
 SURVEY PARTY CHIEF _____
 WATERSHED REVIEW: _____ DATE _____

DEPICTION OF MONUMENTS: _____ DATE _____
 SURVEY PARTY CHIEF _____
 WATERSHED REVIEW: _____ DATE _____

SUBMITTED: _____ DATE _____
 R.C.E. _____
 EXP. _____
 SUPERVISING CIVIL ENGINEER _____
 APPROVED: _____ DATE _____
 R.C.E. _____
 EXP. _____
 CITY ENGINEER _____

DESIGN: _____
 DRAWN: _____
 CHECK: _____
 AS BUILT: _____
 HORIZ.: AS SHOWN
 VERT.: _____
 BOOK: _____
 DATE: 05/12/23



BERKELEY MARINA DOCK REPLACEMENT (D-E)
 CITY OF BERKELEY, ALAMEDA COUNTY, CALIFORNIA
 ELECTRICAL PLAN DEMOLITION WORK
 DOCK "D & E"

PLAN _____
 FILE _____
 E-003
 SHEET 30 OF 51

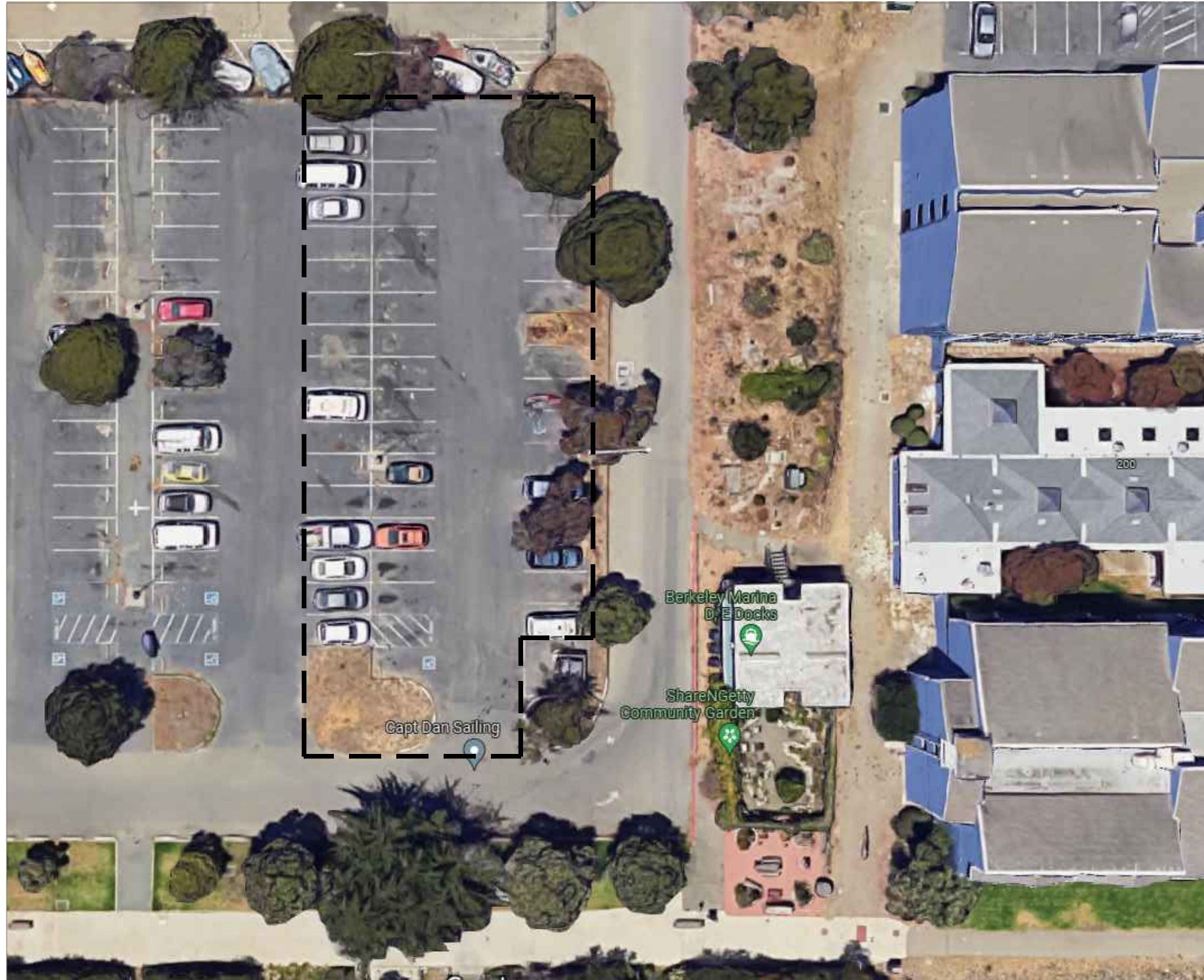

CONSTRUCTION STAGING AREA – DOCK "D & E" 1

SCALE: NTS

E-004

SHEET NOTES

- REFER TO SHEET E-001 FOR ELECTRICAL LEGEND, ABBREVIATIONS, AND GENERAL NOTES.

DRAFT 90% Submittal

PLOTTED BY: MINH TRAN PLOT DATE: 5/20/23 4:26:08 PM

REVISION	MARK	DATE	DESCRIPTION
B		05-12-2023	90% PROGRESS SUBMITTAL
A		03-23-2023	60% PROGRESS SUBMITTAL
			APPROVAL



PROJECT MANAGER: _____ DATE: _____

0 1 2 3
FOR REDUCED PLANS - ORIGINAL SCALE IS IN INCHES

DEPICTION OF MONUMENTS: _____ DATE: _____

SURVEY PARTY CHIEF: _____

WATERSHED REVIEW: _____ DATE: _____

SUBMITTED: _____ DATE: _____

R.C.E. EXP. _____

SUPERVISING CIVIL ENGINEER: _____

APPROVED: _____ DATE: _____

R.C.E. EXP. _____

CITY ENGINEER: _____

DESIGN: _____ DATE: _____

R.C.E. EXP. _____

DRAWN: _____ DATE: _____

MT. EXP. _____

CHECK: _____ DATE: _____

GC. EXP. _____

AS BUILT: _____



BERKELEY MARINA DOCK REPLACEMENT (D-E)
CITY OF BERKELEY, ALAMEDA COUNTY, CALIFORNIA

ELECTRICAL
CONSTRUCTION STAGING AREA

PLAN _____

FILE _____

E-004

SHEET 31 OF 51

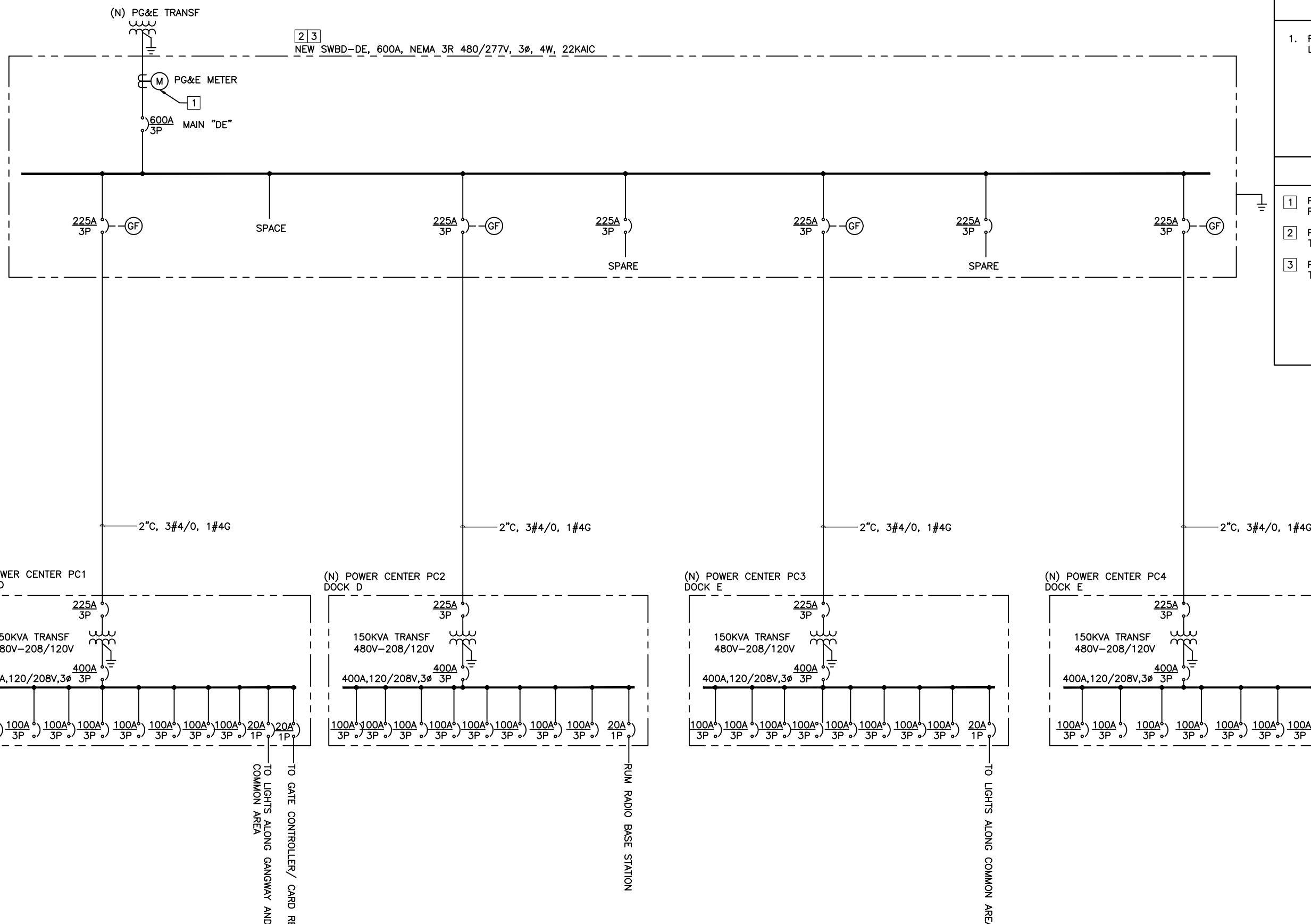

SHEET NOTES

1. REFER TO SHEET E-001 FOR ELECTRICAL LEGEND, ABBREVIATIONS, AND GENERAL NOTES.

KEY NOTES

- 1 PROVIDE METER SOCKET PER PG&E REQUIREMENT. PG&E SHALL PROVIDE METER.
- 2 PROVIDE CAUTION LABEL ON THE SURFACE OF THE SWITCHBOARD DOORS.
- 3 PROVIDE AIC LABEL AND SERVICE DATE ON THE METER SECTION OF THE SWITCHBOARD.

DRAFT 90% Submittal

SINGLE LINE DIAGRAM – DOCK "D&E"

SCALE: NTS

REVISION	MARK	DATE	DESCRIPTION	APPROVAL
C		05-12-2023	90% PROGRESS SUBMITTAL	GC
B		03-23-2023	60% PROGRESS SUBMITTAL	GC
A		08-03-2022	30% PROGRESS SUBMITTAL	GC



PROJECT MANAGER: _____ DATE _____
 SURVEY PARTY CHIEF _____
 WATERSHED REVIEW: _____ DATE _____
 FOR REDUCED PLANS - ORIGINAL SCALE IS IN INCHES

DEPICTION OF MONUMENTS: _____ DATE _____
 SURVEY PARTY CHIEF _____
 WATERSHED REVIEW: _____ DATE _____

SUBMITTED: _____ DATE _____
 SUPERVISING CIVIL ENGINEER _____
 APPROVED: _____ DATE _____
 CITY ENGINEER _____

DESIGN: JH _____
 DRAWN: MT _____
 CHECK: GC _____
 AS BUILT _____
 DATE: 05/12/23



BERKELEY MARINA DOCK REPLACEMENT (D-E)
 CITY OF BERKELEY, ALAMEDA COUNTY, CALIFORNIA
 NEW SINGLE LINE DIAGRAM DOCK "D & E"

PLAN _____
 FILE _____
 E-101
 SHEET 32 OF 51

PLOTTED BY: MINH TRAN PLOT DATE: 05/02/2023 4:24:14 PM



SHEET NOTES

1. REFER TO SHEET E-001 FOR ELECTRICAL LEGEND, ABBREVIATIONS, AND GENERAL NOTES.
2. ALL EQUIPMENT SHOWN ARE NEW, UON.
3. CONTRACTOR SHALL BE RESPONSIBLE FOR ALL REPAIRS AND DAMAGED SPACE DUE TO ANY WORK.
4. ALL (N) POWER CENTERS SHALL BE LOCATED WITHIN THE SPACE WITHOUT PROTRUDING INTO WALKWAY.

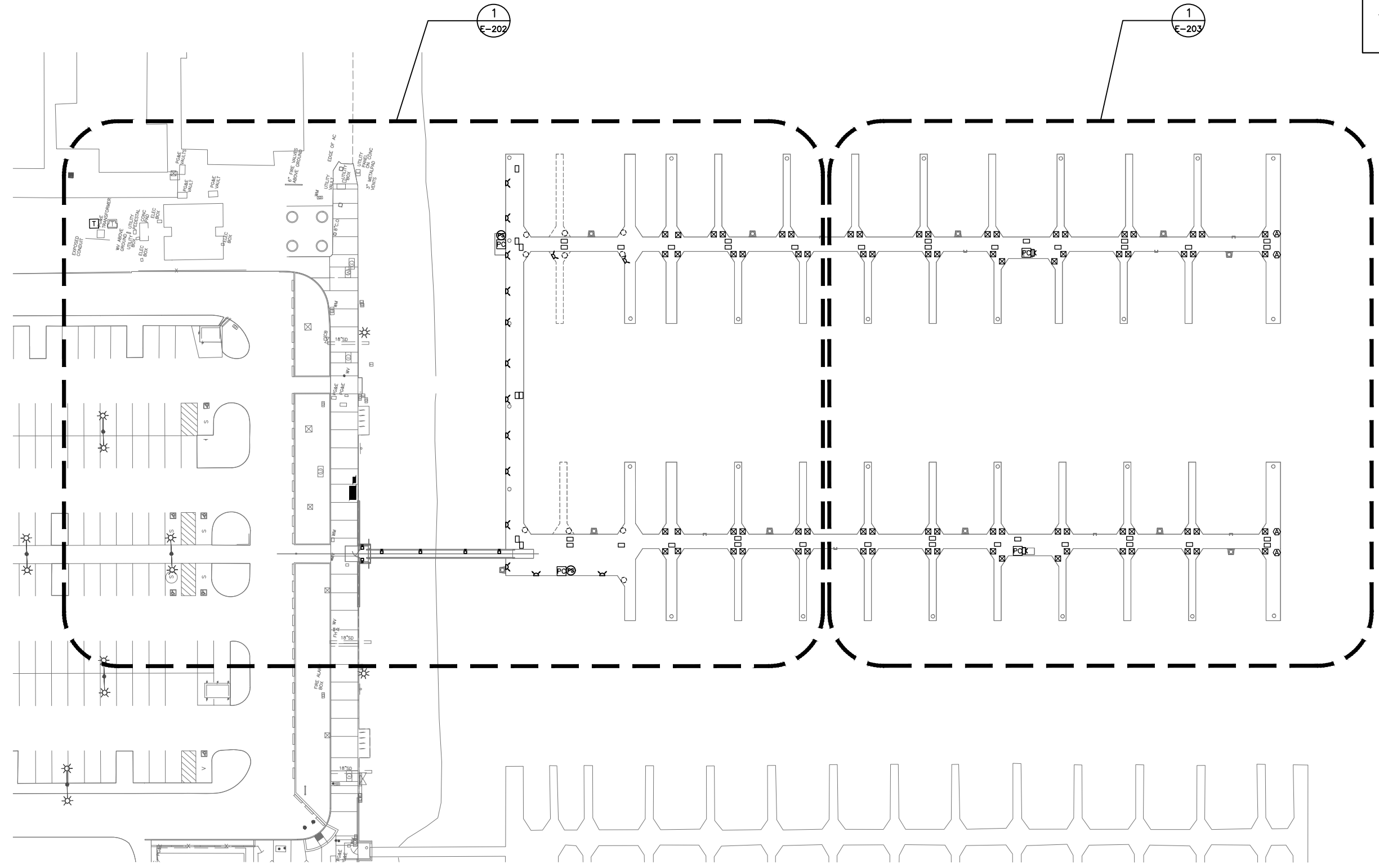

ELECTRICAL SITE PLAN – DOCK "D&E"
 SCALE: 1" = 30'-0"

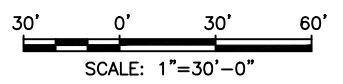

DRAFT 90% Submittal

REVISION	MARK	DATE	DESCRIPTION	APPROVAL
C		05-12-2023	90% PROGRESS SUBMITTAL	GC
B		03-23-2023	60% PROGRESS SUBMITTAL	GC
A		08-03-2022	30% PROGRESS SUBMITTAL	GC



PROJECT MANAGER: _____ DATE _____
 DEPICTION OF MONUMENTS: _____ DATE _____
 SURVEY PARTY CHIEF _____
 WATERSHED REVIEW: _____ DATE _____

SUBMITTED: _____ DATE _____
 R.C.E. _____
 SUPERVISING CIVIL ENGINEER _____
 EXP. _____
 APPROVED: _____ DATE _____
 R.C.E. _____
 CITY ENGINEER _____
 EXP. _____

DESIGN: JH _____
 DRAWN: MT _____
 CHECK: GC _____
 AS BUILT _____
 DATE: 05/12/23

HORIZ. 1" = 30'-0"
 VERT. _____
 BOOK _____
 DATE 05/12/23



BERKELEY MARINA DOCK REPLACEMENT (D-E)
 CITY OF BERKELEY, ALAMEDA COUNTY, CALIFORNIA
ELECTRICAL SITE PLAN
 DOCK "D & E"

PLAN _____
 FILE _____
 E-201
 SHEET 33 OF 51

PLOTTED BY: MINH TRAN PLOT DATE: 5/20/23 4:24:35 PM



LIGHT FIXTURE SCHEDULE

SYMBOL	TYPE	VOLTAGE	WATTAGE	DESCRIPTION AND MANUFACTURER
	L1	120V	9W LED	BOLLARD LIGHTING FIXTURE, 24 INCHES TALL. OUTDOOR RATING, DESIGNED TO WITHSTAND THE HARSH MARINE ENVIRONMENTS. EATON: MARINER LIGHTING BOLLARD 9W OR EQUAL.
	L2	120V	15W LED	RAIL LIGHTING FIXTURE. DESIGNED TO WITHSTAND IF ADE AND ABRASION REISTANT, POLYESTER POWDERCOAT, CUSTOM COLOR FOR MARINE AND CORROSIVE FINISH. KIM LIGHTING: KFL2RGBW-11L-15-RGBW-HF-UNV-Y-LTG-JB1-CC OR EQUAL.

SHEET NOTES

- REFER TO SHEET E-001 FOR ELECTRICAL LEGEND, ABBREVIATIONS, AND GENERAL NOTES.
- CONTRACTOR SHALL BE RESPONSIBLE FOR ALL REPAIRS AND DAMAGED SPACE DUE TO ANY WORK.
- ALL EQUIPMENT SHOWN ARE NEW, UON.
- MAINTAIN POWER CONTINUITY TO CIRCUITS AND LOADS UNAFFECTED AREAS.

KEY NOTES

- COORDINATE WITH PG&E. PROVIDE NEW CONDUIT PER PG&E REQUIREMENT.
- PROVIDE NEW STAINLESS STEEL PULL BOX.
- RUN PVC SCHEDULE 80 UNDERNEATH THE GANGWAY WITH STAINLESS STEEL MOUNT HARDWARE.
- PROVIDE NEW CONDUIT TO THE NEAREST (N) PULL BOX ALONG THE SIDE OF THE EDGE OF THE DOCK.
- PROVIDE NEW WIRES WITH FLEX CONDUIT IN (N) RACEWAY.
- PROVIDE NEW PHOTOCELL SENSOR TO CONTROL (N) DOCK LIGHTS. PROVIDE MOUNTING AND SUPPORT AS NEEDED.
- PROVIDE (N) LED BOLLARD FIXTURE.
- PROVIDE (N) RAIL LED LIGHT FIXTURE. PROVIDE MOUNTING AND SUPPORT AS NEEDED.
- TYPE NEWPORT POWER PEDESTAL.
- 1" FROM COMM PULL BOX TO EACH PEDESTAL.
- PROVIDE POWER AND COMM CONDUIT STUB UPS FOR FUTURE PEDESTAL.
- PROVIDE CONDUIT WITH WIRE AS RECOMMENDED BY MANUFACTURER. PROVIDE RACEWAYS AND WIRING TO ASSOCIATED GATE CONTROLLER HARDWARE. COORDINATE THE LOCATION OF GATE CONTROLLER/CARD READER.

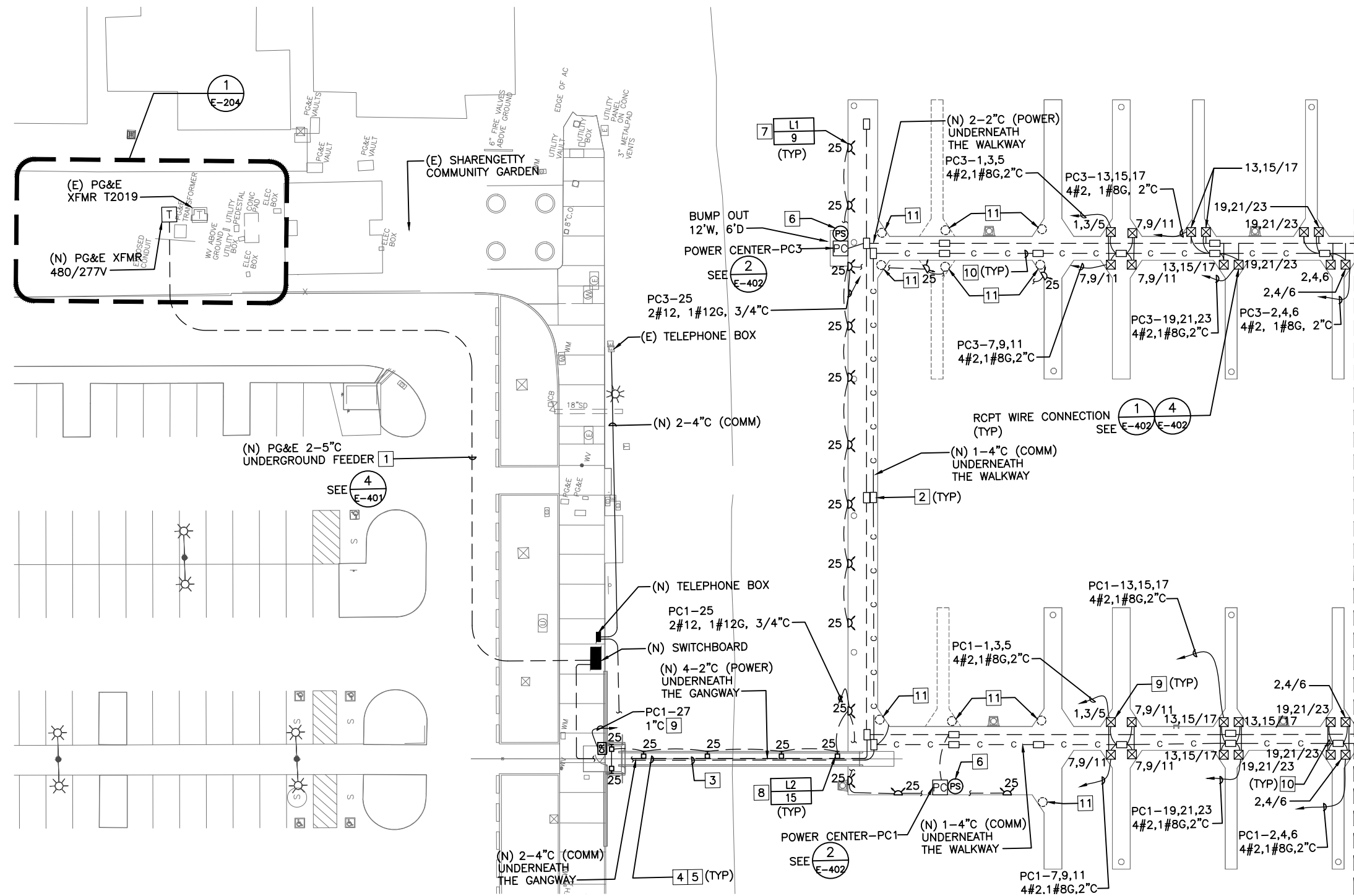

MATCHLINE SEE SHEET E-203

PLAN 1
SCALE: 1" = 20'-0"

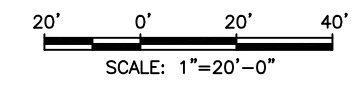

DRAFT 90% Submittal

REVISION	MARK	DATE	DESCRIPTION	APPROVAL
B		05-12-2023	90% PROGRESS SUBMITTAL	OC
A		03-23-2023	60% PROGRESS SUBMITTAL	OC

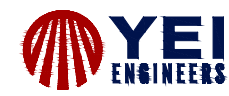

PROJECT MANAGER: _____ DATE _____
 DEPICTION OF MONUMENTS: _____ DATE _____
 SURVEY PARTY CHIEF _____
 WATERSHED REVIEW: _____ DATE _____

SUBMITTED: _____ DATE _____
 R.C.E. _____
 EXP. _____
 SUPERVISING CIVIL ENGINEER _____
 APPROVED: _____ DATE _____
 R.C.E. _____
 EXP. _____
 CITY ENGINEER _____

DESIGN: _____ DATE _____
 HORIZ. 1" = 20'-0"
 VERT. _____
 DRAWN: _____
 CHECK: _____
 AS BUILT _____

HORIZ. 1" = 20'-0"
 VERT. _____
 BOOK _____
 DATE 05/12/23



BERKELEY MARINA DOCK REPLACEMENT (D-E)
 CITY OF BERKELEY, ALAMEDA COUNTY, CALIFORNIA
 PLAN - DOCK "D & E"
 SHEET 1 OF 2

FILE _____
 E-202
 SHEET 34 OF 51

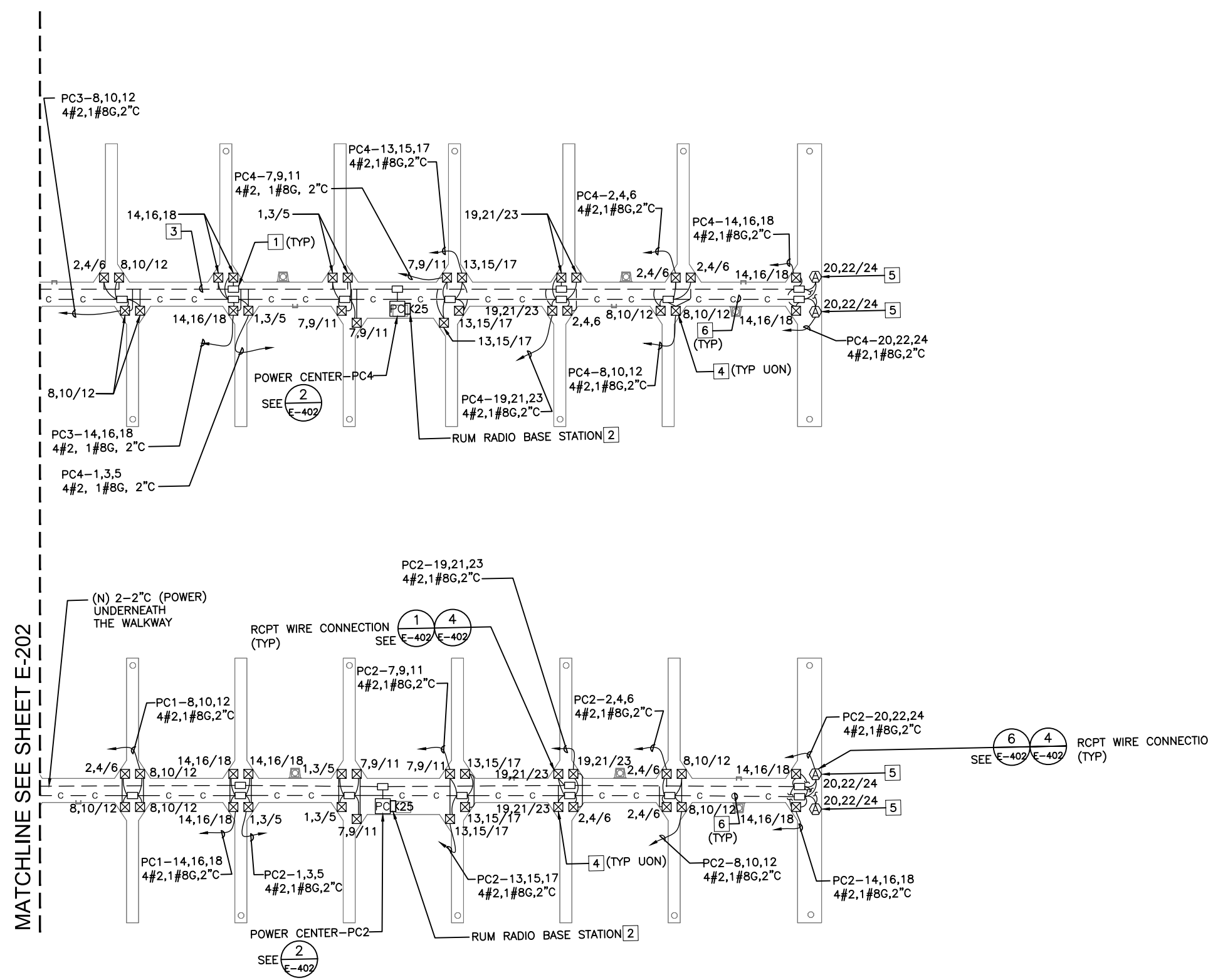

MATCHLINE SEE SHEET E-202

PLAN 2
SCALE: 1" = 20'-0"

1
E-203

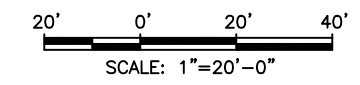

SHEET NOTES

1. REFER TO SHEET E-001 FOR ELECTRICAL LEGEND, ABBREVIATIONS, AND GENERAL NOTES.
2. CONTRACTOR SHALL BE RESPONSIBLE FOR ALL REPAIRS AND DAMAGED SPACE DUE TO ANY WORK.
3. ALL EQUIPMENT SHOWN ARE NEW, UON.
4. MAINTAIN POWER CONTINUITY TO CIRCUITS AND LOADS UNAFFECTED AREAS.

KEY NOTES

- 1 PROVIDE NEW STAINLESS STEEL PULL BOX.
- 2 PROVIDE STANDALONE POLE SUPPORT FOR RUM BASE STATION.
- 3 PROVIDE NEW WIRES WITH FLEX CONDUIT IN (N) RACEWAY.
- 4 TYPE NEWPORT POWER PEDESTAL.
- 5 TYPE LIGHTHOUSE POWER PEDESTAL.
- 6 1" FROM COMM PULL BOX TO EACH PEDESTAL.

DRAFT 90% Submittal

REVISION	MARK	DATE	DESCRIPTION
B		05-12-2023	90% PROGRESS SUBMITTAL
A		03-23-2023	60% PROGRESS SUBMITTAL
			APPROVAL



PROJECT MANAGER:	DATE	DEPICTION OF MONUMENTS:	DATE
SURVEY PARTY CHIEF:		WATERSHED REVIEW:	DATE

SUBMITTED:	DATE	DESIGN:	JH	HORIZ.:	1" = 20'-0"
SUPERVISING CIVIL ENGINEER:	R.C.E.	DRAWN:	MT	VERT.:	
APPROVED:	DATE	CHECK:	GC	BOOK:	
CITY ENGINEER:	R.C.E.	AS BUILT:		DATE:	05/12/23

DATE	EXP.	DATE	EXP.
DATE	EXP.	DATE	EXP.

DATE	EXP.	DATE	EXP.
DATE	EXP.	DATE	EXP.



BERKELEY MARINA DOCK REPLACEMENT (D-E)
CITY OF BERKELEY, ALAMEDA COUNTY, CALIFORNIA
PLAN - DOCK "D & E"
SHEET 2 OF 2

PLAN
FILE
E-203
SHEET 35 OF 51

PLOTTED BY: MINH TRAN PLOT DATE: 5/10/2023 4:26:59 PM

(N) CONCRETE PAD
90"W, 106"L, 6"H 1

(E) PG&E
XFMR T2019

(E) SHARENGETTY
COMMUNITY GARDEN

(N) PG&E XFMR 1 2
480/277V



CONTINUE ON E-202

PLAN 1
SCALE: NTS

1
E-204

SHEET NOTES

1. REFER TO SHEET E-001 FOR ELECTRICAL LEGEND, ABBREVIATIONS, AND GENERAL NOTES.
2. CONTRACTOR SHALL BE RESPONSIBLE FOR ALL REPAIRS AND DAMAGED SPACE DUE TO ANY WORK.
3. ALL EQUIPMENT SHOWN ARE NEW, UON.
4. MAINTAIN POWER CONTINUITY TO CIRCUITS AND LOADS UNAFFECTED AREAS.

KEY NOTES

- 1 COORDINATE WITH PG&E FOR (N) TRANSFORMER SERVICE AND UTILITY METER TO BE PROVIDED BY PG&E. PROVIDE GROUNDING PER PG&E REQUIREMENTS. PROVIDE PG&E APPROVED TRANSFORMER PAD PER PG&E GREENBOOK DETAILS AND LAYOUT.
- 2 (N) PG&E TRANSFORMER NEEDS 4' IN FRONT CLEARANCE. TREES AND BUSHES NEED TO BE CUT AND TRIMMED. COORDINATE WITH CITY OF BERKELEY BEFORE CUT TREE OR TRIM.
- 3 ELECTRICAL HANDHOLE TO BE REMAINED AND PROTECTED IN PLACE.
- 4 DATA BOX TO BE REMAINED AND PROTECTED IN PLACE.
- 5 WATER LINE TO BE REMAINED AND PROTECTED IN PLACE.

DRAFT 90% Submittal

PLOTTED BY: MINH TRAN PLOT DATE: 05/02/2023 4:26:07 PM



1 PHOTO 1
SCALE: NTS



2 PHOTO 2
SCALE: NTS



3 PHOTO 3
SCALE: NTS

REVISION	MARK	DATE	DESCRIPTION	APPROVAL
B		05-12-2023	90% PROGRESS SUBMITTAL	CC
A		03-23-2023	60% PROGRESS SUBMITTAL	CC



PROJECT MANAGER: _____ DATE _____
 SURVEY PARTY CHIEF _____
 WATERSHED REVIEW: _____ DATE _____
 FOR REDUCED PLANS - ORIGINAL SCALE IS IN INCHES

DEPICTION OF MONUMENTS: _____ DATE _____
 SUPERVISING CIVIL ENGINEER _____
 APPROVED: _____ DATE _____
 CITY ENGINEER _____

SUBMITTED: _____ DATE _____
 R.C.E. _____
 EXP. _____
 SUPERVISING CIVIL ENGINEER _____
 APPROVED: _____ DATE _____
 R.C.E. _____
 EXP. _____
 CITY ENGINEER _____

DESIGN: JH _____
 DRAWN: MT _____
 CHECK: GC _____
 AS BUILT _____
 HORIZ.: NTS _____
 VERT.: _____
 BOOK: _____
 DATE: 05/12/23



BERKELEY MARINA DOCK REPLACEMENT (D-E)
 CITY OF BERKELEY, ALAMEDA COUNTY, CALIFORNIA
 PLAN AND LANDSIDE PHOTOS

PLAN _____
 FILE _____
 E-204
 SHEET 36 OF 51

SHEET NOTES

1. REFER TO SHEET E-001 FOR ELECTRICAL LEGEND, ABBREVIATIONS, AND GENERAL NOTES.
2. ALL GANGWAY UNISTRUT & SUPPORT SHALL BE STAINLESS STEEL AND ALL JUNCTION BOXES, FITTINGS, SCREWS, RIVETS OR BOLTS, NUTS SHALL BE 316 STAINLESS STEEL.
3. ALL FLEXIBLE CONDUIT SHALL BE PVC COATED, LIQUID-TIGHT STEEL CONDUIT AND ALL RIGID CONDUIT SHALL BE PVC SCH-80, UNLESS OTHERWISE NOTED.
4. PROVIDED GROUND WIRE #2/0 FROM SWITCHBOARD ENCLOSURE TO (E) GROUND LEG.

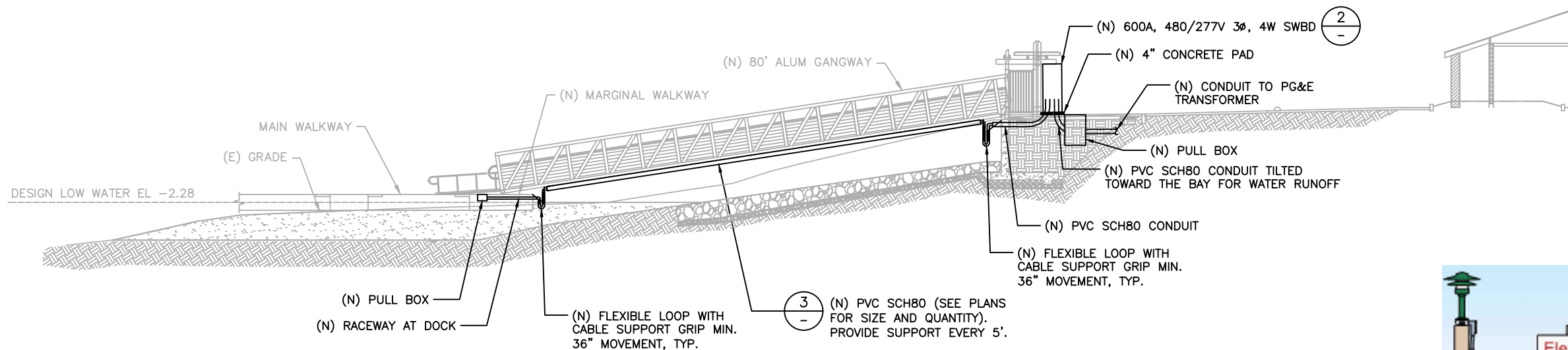

SHORE TO DOCK CONDUIT CROSS SECTION (1)
SCALE: NTS

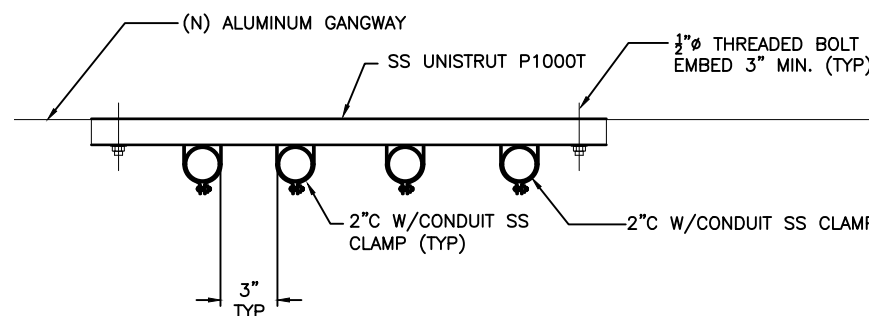

CONDUIT SUPPORT DETAIL (3)
SCALE: NTS

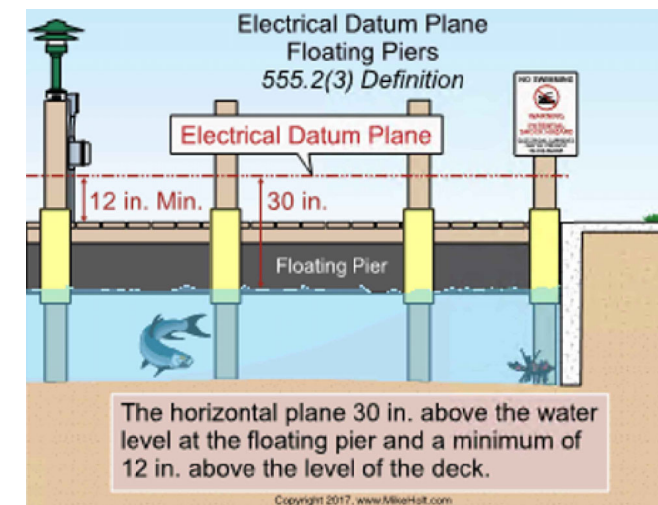

ELECTRICAL DATUM PLANE (5)
SCALE: NTS

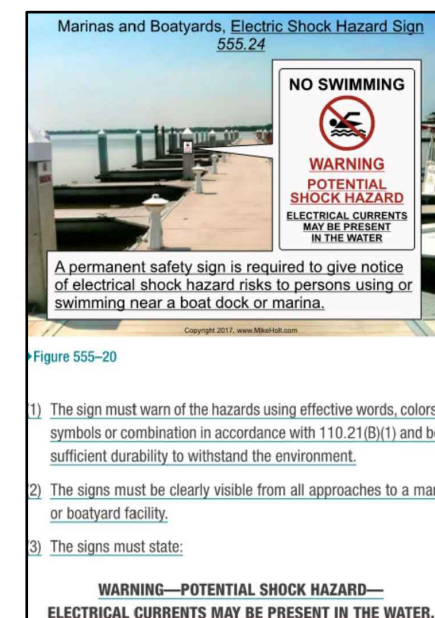

WARNING SIGN DETAIL (6)
SCALE: NTS

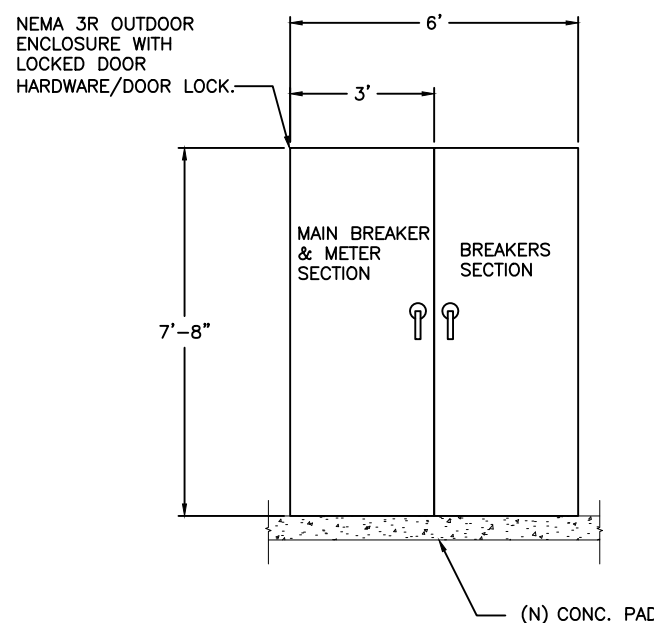

SWITCHBOARD DETAIL (2)
SCALE: NTS

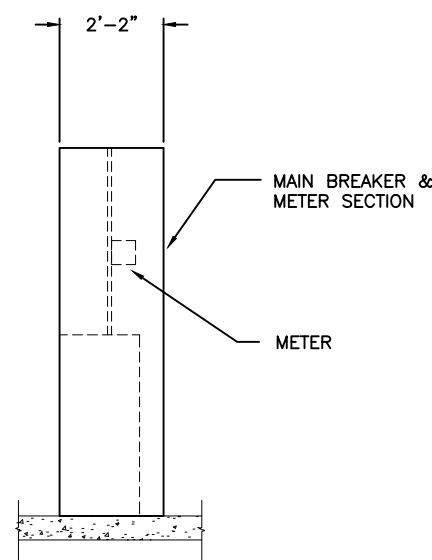

TRENCH DETAIL (4)
SCALE: NTS



PROJECT MANAGER:	DATE	DEPICTION OF MONUMENTS:	DATE	SUBMITTED:	DATE	DESIGN:	JH	HORIZ.:	NTS
		SURVEY PARTY CHIEF:		SUPERVISING CIVIL ENGINEER:	R.C.E.	DRAWN:	MT	VERT.:	
		WATERSHED REVIEW:	DATE	APPROVED:	DATE	CHECK:	GC	BOOK:	
				CITY ENGINEER:	EXP.	AS BUILT:		DATE:	05/12/23

0	1	2	3
FOR REDUCED PLANS - ORIGINAL SCALE IS IN INCHES			

DATE	DATE	DATE	DATE
EXP.	EXP.	EXP.	EXP.

DATE	DATE	DATE	DATE
EXP.	EXP.	EXP.	EXP.



BERKELEY MARINA DOCK REPLACEMENT (D-E)
CITY OF BERKELEY, ALAMEDA COUNTY, CALIFORNIA
ELECTRICAL DETAILS
SHEET 1 OF 2

FILE	
E-401	
SHEET 37 OF 51	

DRAFT 90% Submittal

OC	OC	APPROVAL
90% PROGRESS SUBMITTAL	60% PROGRESS SUBMITTAL	DESCRIPTION
05-12-2023	03-23-2023	DATE
B	A	REVISION
		MARK

DRAFT 90% Submittal

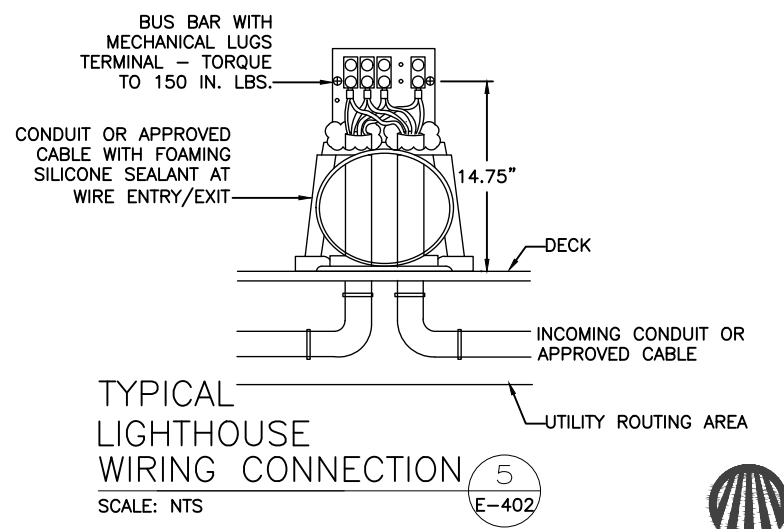
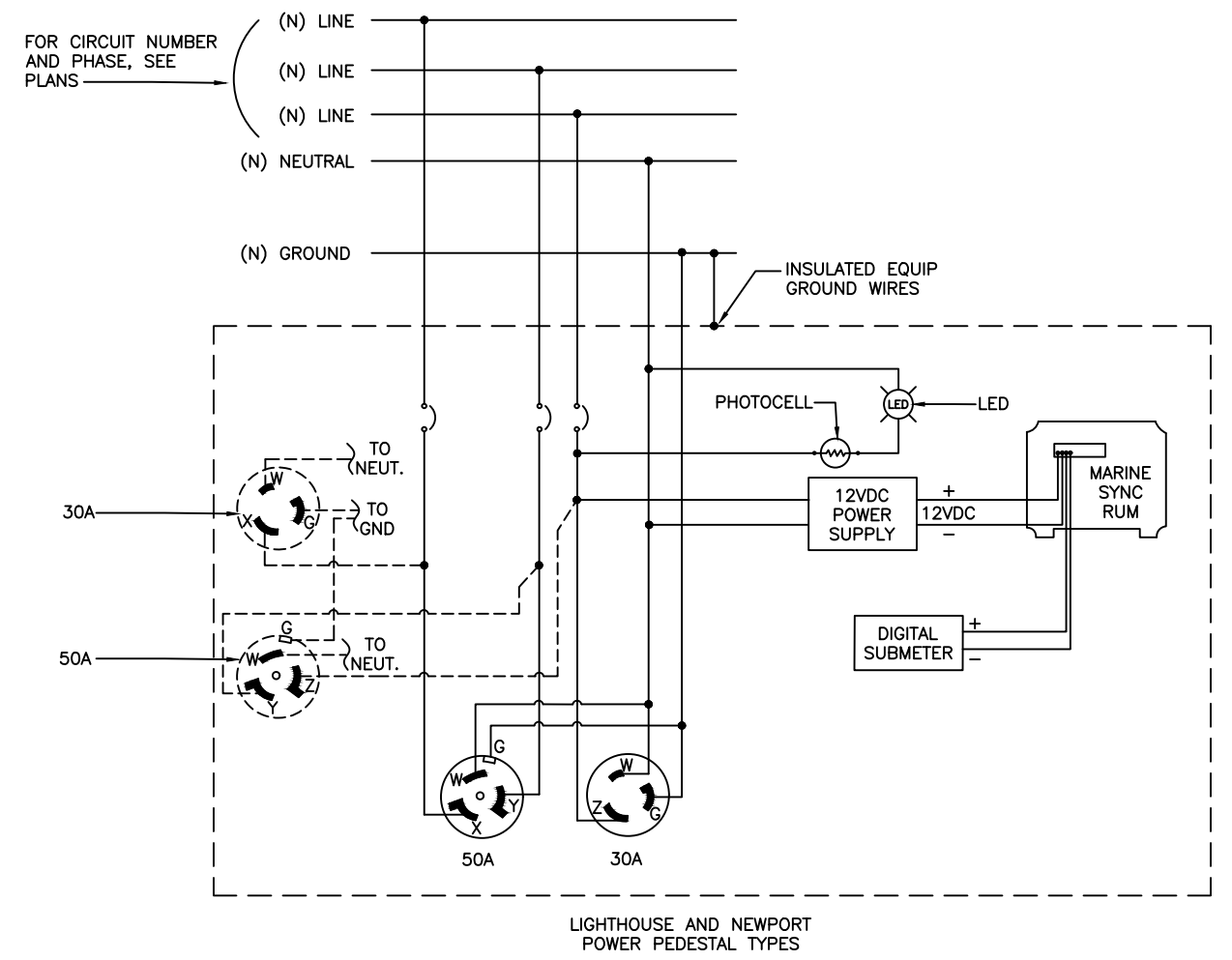
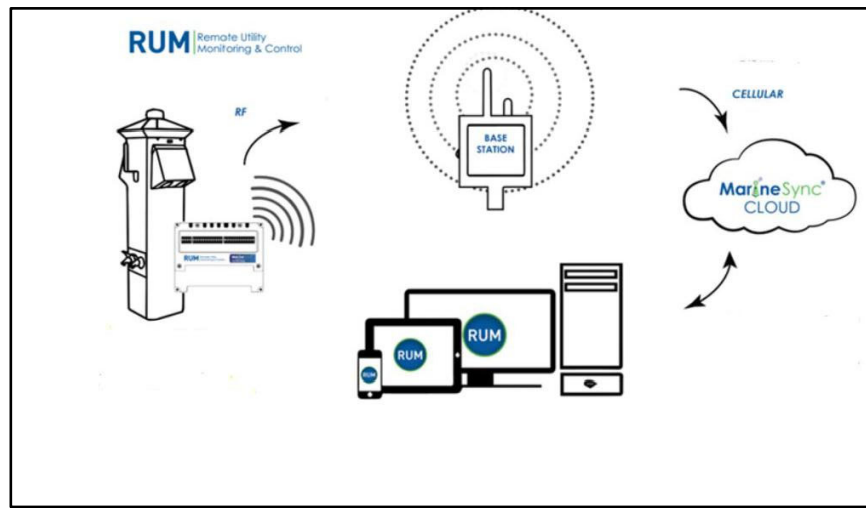
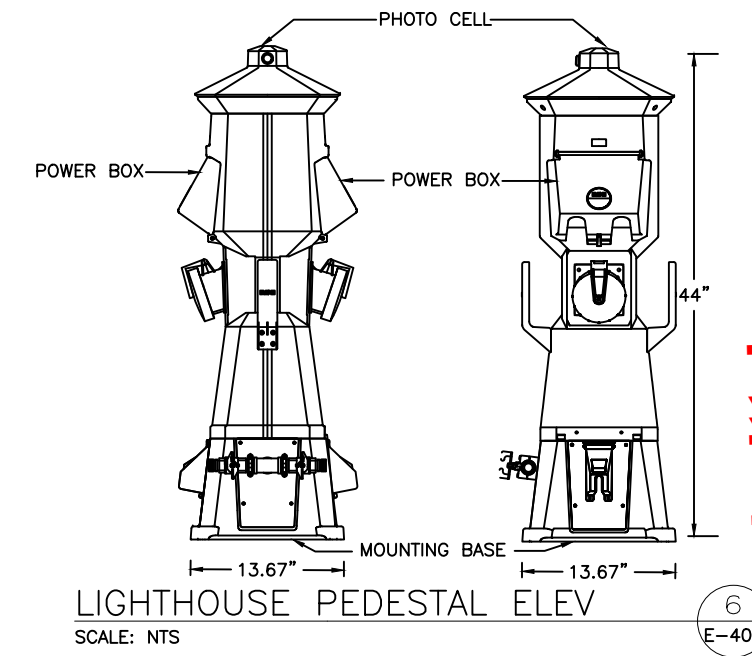
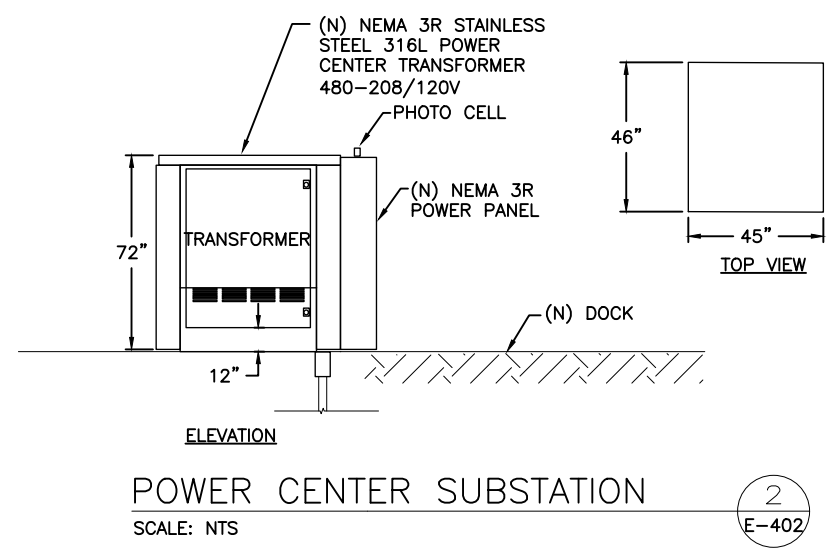
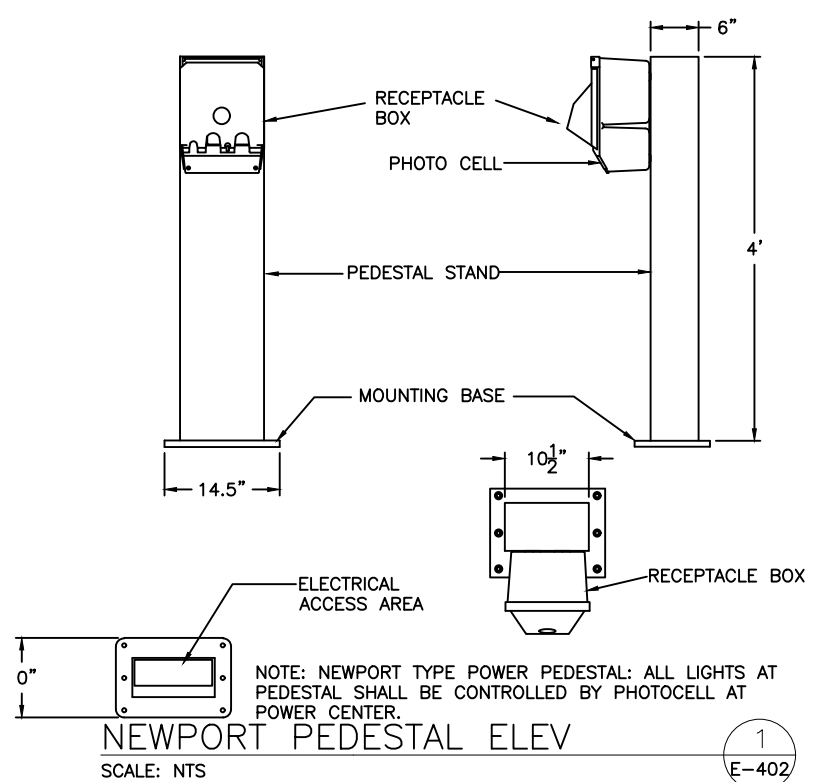

PROJECT MANAGER: _____ DATE _____	DEPICTION OF MONUMENTS: _____ DATE _____	SUBMITTED: _____ DATE _____	DESIGN: _____	HORIZ.: NTS			BERKELEY MARINA DOCK REPLACEMENT (D-E) CITY OF BERKELEY, ALAMEDA COUNTY, CALIFORNIA ELECTRICAL DETAILS SHEET 2 OF 2	FILE _____
SURVEY PARTY CHIEF: _____	WATERSHED REVIEW: _____ DATE _____	SUPERVISING CIVIL ENGINEER: _____	DRAWN: _____	VERT.: _____				90% PROGRESS SUBMITTAL 05-12-2023 60% PROGRESS SUBMITTAL 03-23-2023
FOR REDUCED PLANS - ORIGINAL SCALE IS IN INCHES		APPROVED: _____ DATE _____	CHECK: _____	BOOK: _____	REVISION	DESCRIPTION	DATE	MARK
		CITY ENGINEER: _____	AS BUILT: _____	DATE: 05/12/23	B	A		

FIRE PROTECTION LEGEND

SYMBOL	ABBREV	DESCRIPTION	ABBREV. /SYMBOL	DESCRIPTION	ABBREV	DESCRIPTION
		AREA OF WORK	APPROX	APPROXIMATE	THD	THREADED
			CL	CENTER LINE	TYP	TYPICAL
	CW	DOMESTIC WATER	CFC	CALIFORNIA FIRE CODE	UNO	UNLESS NOTED OTHERWISE
		DOUBLE CHECK VALVE BACKFLOW PREVENTER ASSEMBLY	CONC	CONCRETE	U/G	UNDERGROUND
		EXISTING EQUIPMENT OR PIPING TO REMAIN	CONN	CONNECT OR CONNECTION	UL	UNDERWRITER'S LABORATORY
		FIRE HYDRANT	CONT	CONTINUATION	W/	WITH
		FIRE DEPARTMENT CONNECTION	DEPT	DEPARTMENT		
	FW	FIRE WATER	DI	DUCTILE IRON		
		PIPE TEE UP	DIA/Ø	DIAMETER		
		PIPE TEE DOWN	DIM	DIMENSION		
		PIPE DOWN	DWG	DRAWING		
		PIPE UP	(E)	EXISTING		
	POC	POINT OF CONNECTION	EA	EACH		
	POD	POINT OF DISCONNECTION	FDC	FIRE DEPARTMENT CONNECTION		
		PRESSURE GAUGE	FLR	FLOOR		
		REMOVE EXISTING EQUIPMENT OR PIPING	FP	FIRE PROTECTION		
	GV	GATE/ISOLATION VALVE	FW	FIRE WATER		
	U	UNION	GA	GAUGE/ GAGE		
	RED	REDUCER	GALV	GALVANIZED		
	CH V	CHECK VALVE	GPM	GALLONS PER MINUTE		
		PIPE PENETRATION WITH SLEEVE	ID	INSIDE DIAMETER		
	W	FLOW SWITCH	M	METER		
		SECTION IDENTIFICATION LETTER	MAX	MAXIMUM		
		DRAWING NUMBER ON WHICH SECTION IS DRAWN	MIN	MINIMUM		
		DRAWING NUMBER(S) FROM WHICH SECTION IS TAKEN	NC	NORMALLY CLOSED		
		SECTION IDENTIFICATION LETTER	NFPA	NATIONAL FIRE PROTECTION AGENCY		
		SECTION IS TAKEN AND DRAWN ON SAME SHEET	NIC	NOT IN CONTRACT		
		DETAIL IDENTIFICATION NUMBER	NTS	NOT TO SCALE		
		DRAWING NUMBER ON WHICH DETAIL IS DRAWN	OD	OUTSIDE DIAMETER		
		DRAWING NUMBER(S) FROM WHICH DETAIL IS TAKEN	OS&Y	OUTSIDE SCREW & YOKE		
		DETAIL IDENTIFICATION NUMBER	PD	PRESSURE DROP		
		DETAIL IS TAKEN AND DRAWN ON SAME SHEET	PSIG	POUNDS PER SQUARE INCH GAUGE QUANTITY		
			QTY	QUANTITY		
			SS	STAINLESS STEEL		
			STD	STANDARD		
			STL	STEEL		
			TEMP	TEMPERATURE		

BACKFLOW PREVENTER						
EQPM ID	LOCATION	AREA SERVE	TYPE	SIZE	SERVICE	REMARKS
				IN.		
RPBFP-1	OUTDOORS	REFER TO DRAWINGS	REDUCED PRESSURE PRINCIPLE/ZONE	4	FIRE HOSE FIRE WATER SUPPLY	SEE NOTES
NOTES: 1. AWWA C511, ASSE 1013 LISTED, DUCTILE IRON BODY, PROVIDE WITH TWO POSITIVE SEATING STAINLESS STEEL SEATED CHECK VALVES AND TWO WEDGE GATE OS&Y VALVES, MODULAR HYDRAULICALLY DEPENDENT DIFFERENTIAL RELIEF VALVE, AND BACKSIPHONAGE. PROVIDE WITH ANTICORROSION INHIBITOR PRIMER, MICROBRIAL INHIBITOR AND EPOXY-POLYESTER TOPCOAT. PROVIDE WITH OUTDOOR CORROSION RESISTANT COATED VANDAL PROOF CAGE ANCHORED TO CONCRETE PAD.						

SITWORK GENERAL NOTES

- FIELD VERIFY ALL DIMENSIONS AND EXISTING CONDITIONS, INCLUDING ALL EXISTING UNDERGROUND UTILITIES PRIOR TO COMMENCING WORK AND COORDINATE WITH ALL OTHER TRADES. ALL DISCREPANCIES OR POTENTIAL PROBLEMS SHALL BE BROUGHT TO THE ATTENTION OF THE ENGINEER AND OWNER PRIOR TO INSTALLATION. THE BID SHALL CONTAIN UNIT PRICES OF ITEMS THAT MAY NEED TO BE REPLACED AND REINSTALLED.
- IN CASE OF DIFFERENCE BETWEEN CODES, SPECIFICATIONS, STATE LAWS, LOCAL ORDINANCES, INDUSTRY STANDARDS, UTILITY COMPANY REGULATIONS, AND CONTRACT DOCUMENTS, THE MOST STRINGENT SHALL GOVERN. PROMPTLY NOTIFY THE OWNER IN WRITING OF ANY SUCH DIFFERENCE.
- MATERIALS AND EQUIPMENT FURNISHED AND INSTALLED SHALL BE NEW, FREE FROM DEFECTS AND SHALL BE GUARANTEED FOR A PERIOD OF ONE YEAR FROM DATE OF FINAL ACCEPTANCE BY THE OWNER. SHOULD ANY PROBLEMS DEVELOP DURING THE PERIOD DUE TO FAULTY WORKMANSHIP OR MATERIAL AND LABOR IT SHALL BE CORRECTED WITHOUT COST TO THE OWNER.
- THE DRAWINGS ARE DIAGRAMMATIC AND SHALL NOT BE SCALED TO DETERMINE THE EXACT LOCATION OF THE PIPING.
- ALL PIPES AND FITTINGS UTILIZED IN WATER SUPPLY SYSTEMS SHALL ALSO CONFORM TO NSF 61 AS REQUIRED BY THE CALIFORNIA PLUMBING CODE.
- COORDINATE INSTALLATION OF PIPING AND ACCESSORIES WITH OTHER TRADES PRIOR TO INSTALLATION.
- PLANS ARE BASED ON ANTICIPATED EQUIPMENT SIZE AND CONFIGURATION. CONTRACTOR SHALL MODIFY ARRANGEMENT TO SUIT ACTUAL PURCHASED EQUIPMENT AS REQUIRED FOLLOWING THE CRITERIA ESTABLISHED BY THE PLAN. DEPARTURES FROM THE CONTRACT DRAWING RESULT FROM CHANGES IN EQUIPMENT SIZES AND CONFIGURATIONS, OR RE-ARRANGEMENTS TO ACCOMMODATE FIELD CONDITIONS, SHALL BE SUBMITTED IN DETAIL FOR THE ENGINEER'S APPROVAL.
- NOTIFY ENGINEER AND OWNER AT LEAST ONE (1) WEEK IN ADVANCE TO COORDINATE SHUTDOWN FOR RECONNECTION TO (E) AFFECTED UTILITIES.
- FIRE PROTECTION WATER PIPING AS SHOWN ON THE DRAWINGS ARE DIAGRAMMATIC AND SHALL BE FABRICATED AND INSTALLED ON ACTUAL FIELD MEASUREMENT. FIRE PROTECTION WATER PIPING SHALL BE INSTALLED PROPERLY TO AVOID OTHER UTILITIES IN THE AREA OF WORK.
- PROVIDE VALVE BOX AND COVER FOR ALL (N) VALVES INSTALLED UNDERGROUND. INSTALL VALVE BOXES AND COVERS PER MANUFACTURER'S RECOMMENDATION.
- PROVIDE THRUST BLOCKS AND RESTRAINTS FOR THE (N) FIRE WATER PIPING.
- TRACER WIRE SHALL BE RHW #10 AWG STRANDED. TRACER WIRE SHALL BE SECURELY FASTENED TO TOP OF NEW BURIED WATER LINES AND SHALL BE PLACED ALONG THE OUTSIDE OF VALVE BOX RISERS WITH ONE FOOT OF SLACK PLACE INSIDE OF VALVE BOX. WIRE SHALL TERMINATE IN EACH BOX IN THE DIRECTION OF THE VALVE CONTROLS.
- CONDUCTIVITY TEST FOR TRACER WIRE SHALL BE PERFORMED AFTER BACKFILL AND COMPACTION.
- FIREWATER ISOLATION VALVES SHALL BE ACCESSIBLE.
- THE UNDERGROUND PIPING SYSTEM INSTALLATION SHALL BE IN ACCORDANCE WITH LATEST NFPA 24 AND SHALL BE INSTALLED BY EXPERIENCED C16 CONTRACTOR OR CLASS A GENERAL CONTRACTOR.
- THE EXISTENCE AND LOCATION OF UNDERGROUND UTILITY PIPELINES SHOWN ON THE PLANS WERE OBTAINED BY A SEARCH OF THE AVAILABLE RECORDS. APPROVAL OF THESE PLANS BY THE ENGINEER DOES NOT CONSTITUTE A REPRESENTATION AS TO THE ACCURACY OR COMPLETENESS OF THE LOCATION OR THE EXISTENCE OF ANY UNDERGROUND UTILITIES WITHIN THE LIMITS OF THIS PROJECT. THE CONTRACTOR IS REQUIRED TO TAKE ALL DUE PRECAUTIONARY MEANS TO PROTECT THE UTILITIES. IT SHALL BE THE CONTRACTOR'S RESPONSIBILITY TO LOCATE, PROTECT, AND MAINTAIN ALL EXISTING UTILITIES WHETHER OR NOT SHOWN ON THE DRAWINGS.
- HYDROSTATIC TESTS OF ALL SYSTEMS SHALL BE CONDUCTED IN ACCORDANCE WITH THE SPECIFICATIONS AND NFPA 14 AND NFPA 24 REQUIREMENTS. THE ENTIRE INSTALLATION SHALL BE INSPECTED AND TESTED IN ACCORDANCE WITH NFPA 14 AND NFPA 24, AND APPROVED BY THE FIRE MARSHAL PRIOR TO FINAL ACCEPTANCE.

FIRE PROTECTION GENERAL NOTES

- REFER TO SPECIFICATIONS FOR MATERIALS AND METHODS OF CONSTRUCTION.
- WORK INCLUDES PROVISION OF COMPLETE FIRE PROTECTION FOR THE DOCKS. CONTRACTOR IS RESPONSIBLE FOR ALL WORK, INCLUDING SHOP DRAWINGS PREPARATION NECESSARY FOR COMPLETE OPERATING SYSTEM.
- PERFORM ALL INSTALLATION WORK IN ACCORDANCE WITH THE LATEST EDITIONS OF NFPA 303 AND IN ACCORDANCE WITH THE CALIFORNIA BUILDING CODE AND CALIFORNIA FIRE CODE PROVISIONS.
- FIELD VERIFICATION OF SYSTEM DESIGN AND LAYOUT PRIOR TO FABRICATION.
- COMPLY WITH DIVISION 01 AND 21 SPECIFICATIONS FOR SUBMITTALS AND INSPECTION.
- FIRE HOSE AND PIPING SYSTEMS INCLUDING FITTINGS AND HANGERS SHALL BE PROTECTED FROM CORROSION IN ACCORDANCE WITH NFPA 303 FIRE PROTECTION STANDARD FOR MARINAS AND BOATYARDS, CURRENT EDITION.
- PROVIDE FIRE PROTECTION ENGINEER STAMPED FIRE SPRINKLER SHOP DRAWING PLAN(S) FOR FIRE MARSHAL'S APPROVAL.
- PROVIDE FIRE PROTECTION SYSTEM FOR THE AREAS AS INDICATED ON THE DRAWINGS.
- CONSTRUCTION SAFETY: ALL WORK SHALL CONFORM TO THE REQUIREMENTS OF OSHA.
- ALL COST FOR INSPECTION, TEST SERVICES, BUILDING PERMITS, LICENSES AND CERTIFICATES SHALL BE THE RESPONSIBILITY OF THE CONTRACTOR UNLESS NOTED OTHERWISE IN THE SPECIFICATIONS.
- PROVIDE HANGERS AND SWAY BRACING AS REQUIRED PER THE LATEST EDITION OF NFPA 14, SPECIFICATION AND LOCAL CODES AND AMENDMENTS.
- ELEVATIONS OF PIPING AND POINT OF CONNECTIONS ABOVE AND BELOW GROUND SHALL BE FIELD VERIFIED PRIOR TO START OF INSTALLATION.
- COORDINATE THE LOCATION OF RISERS, PIPING AND OTHER FIRE WATER SYSTEM COMPONENTS WITH STRUCTURAL AND ELECTRICAL PORTIONS OF THE DOCKS.
- COORDINATE INSTALLATION OF ALL EQUIPMENT AND PIPING WITH OTHER TRADES PRIOR TO INSTALLATION. CONTRACTOR SHALL COORDINATE EXACT LOCATION OF BACKFLOW PREVENTER AND FIRE HOSES PRIOR TO INSTALLATION.
- ALL PIPE PENETRATIONS TO BE SEALED WITH SEALANT.
- CONTRACTOR TO FIELD VERIFY SITE FOR FIRE PROTECTION SYSTEM.
- PIPE HANGERS SHALL BE DESIGNED TO SUPPORT THE WEIGHT OF THE PIPE AND THE WEIGHT OF THE CONTENTS OF THE PIPE. REFER TO DETAILS ON DRAWINGS FOR ATTACHMENTS.
- CHANGES OF PIPE DIRECTION SHALL BE ACCOMPLISHED BY THE USE OF FITTINGS SUITABLE FOR SPRINKLER SYSTEMS AS DEFINED BY NFPA 13 AND THE SPECIFICATIONS.



PROJECT MANAGER: _____ DATE _____
 SURVEY PARTY CHIEF _____
 WATERSHED REVIEW: _____ DATE _____

DEPICTION OF MONUMENTS: _____ DATE _____
 SURVEY PARTY CHIEF _____
 WATERSHED REVIEW: _____ DATE _____

SUBMITTED: _____ DATE _____
 SUPERVISING CIVIL ENGINEER _____
 APPROVED: _____ DATE _____
 CITY ENGINEER _____

DESIGN: _____ B.H. _____
 DRAWN: _____ P.W. _____
 CHECK: _____ P.M. _____
 AS BUILT: _____ DATE 06/12/23



BERKELEY MARINA DOCK REPLACEMENT (D-E)
 CITY OF BERKELEY, ALAMEDA COUNTY, CALIFORNIA
 FIRE PROTECTION GENERAL NOTES,
 LEGEND AND ABBREVIATIONS

PLAN _____
 FILE _____
 SHEET 41 OF 51

DRAFT 90% Submittal

REVISION	MARK	DATE	DESCRIPTION
C		06-12-2023	60% PROGRESS SUBMITTAL
B		03-23-2023	60% PROGRESS SUBMITTAL
A		06-03-2022	30% PROGRESS SUBMITTAL
			APPROVAL

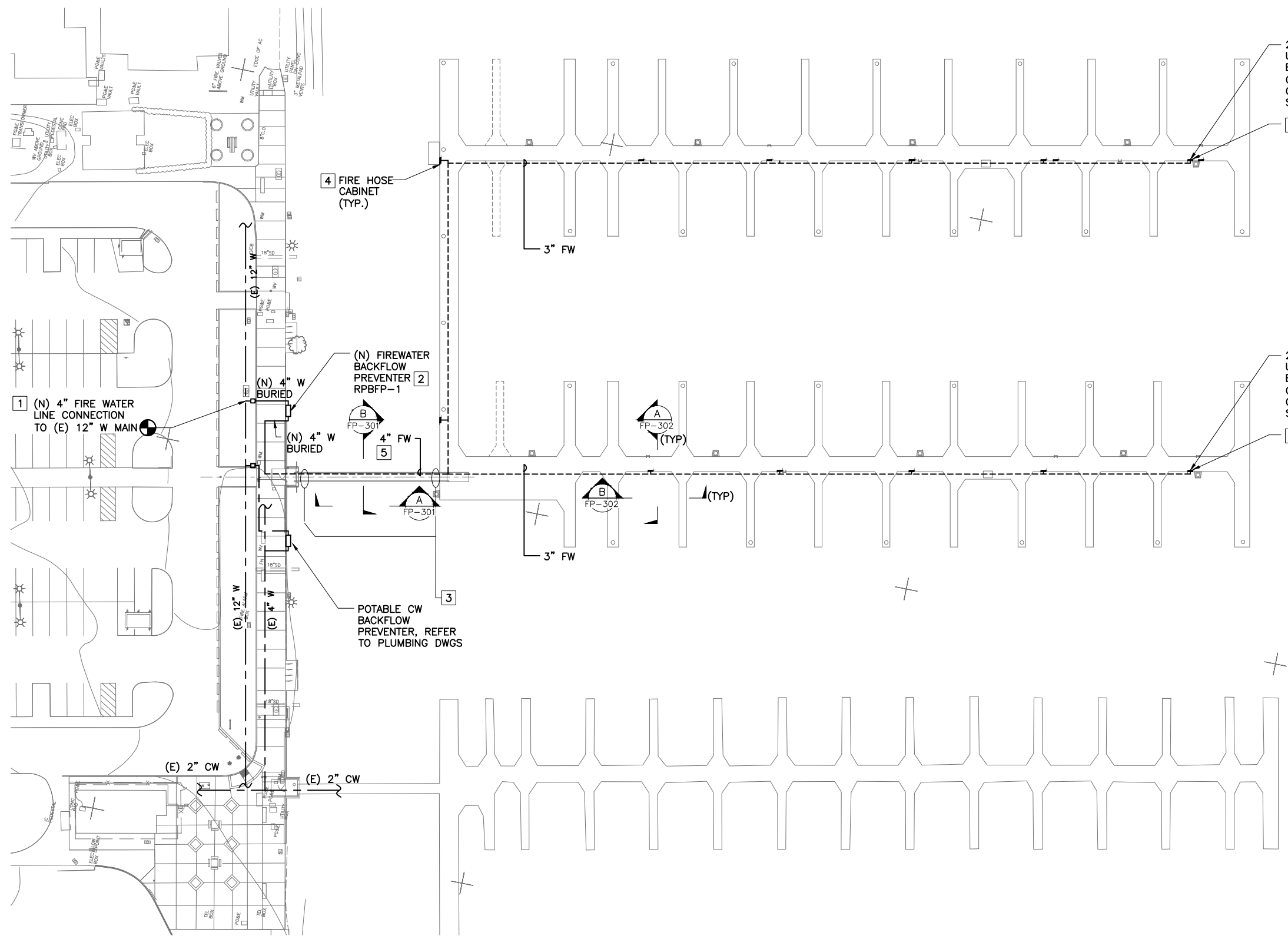

- SHEET NOTES:**
- COORDINATE WITH EAST BAY MUNICIPAL UTILITY DISTRICT (EBMUD) FOR INSTALLATION AND PROPER CONNECTION TO NEW DEDICATED FIRE LINE BACKFLOW PREVENTER.
 - ALL GANGWAY AND DOCKS FIRE WATER LINES SHALL BE HDPE PIPE.
 - PROVIDE THRUST BLOCKS ON (N) UNDERGROUND FIRE WATER PIPE.
 - EBMUD WILL BE RESPONSIBLE FOR FURNISHING AND INSTALLING PIPE CONNECTION AT INDICATED POC LOCATION. PRIOR TO WORK, CONTRACTOR SHALL BE RESPONSIBLE FOR COORDINATING WITH CITY OF BERKELEY AND EBMUD FOR LOCATION OF BACKFLOW PREVENTER.

- KEY NOTES:**
- CONTRACTOR TO FIELD VERIFY LOCATION OF EXISTING LANDSIDE WATERLINE. CONNECT (N) 4-INCH FIRE WATER LINE TO (E) MAIN WATER LINE BELOW GROUND.
 - PROVIDE (N) FIRE WATER DOUBLE CHECK BACKFLOW PREVENTER W/ FIRE DEPARTMENT CONNECTION. LOCATE NEW BACKFLOW PREVENTER ON (N) CONCRETE PAD PER STRUCTURAL DWGS.
 - PROVIDE FLEXIBLE HOSE ON FIRE WATER LINE WHERE GANGWAY JOINTS SHORE AND DOCKS. PROVIDE STAINLESS STEEL KELLUM GRIPS AT ALL FLEXIBLE CONNECTIONS AT GANGWAY.
 - PROVIDE (N) FIRE HOSE CABINETS ON DOCKS. CONNECT (N) FIRE WATER STANDPIPE TO FIRE HOSE CABINET.
 - PROVIDE (N) FIRE WATER PIPE UNDER GANGWAY TIGHT TO UNDERSIDE.

FIRE PROTECTION PLAN NEW WORK - DOCK 'D&E'
SCALE: 1" = 30'-0"

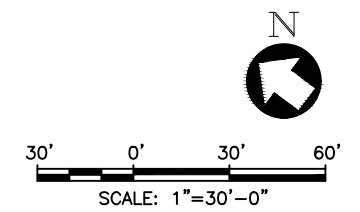

DRAFT 90% Submittal

REVISION	MARK	DATE	DESCRIPTION	APPROVAL
C		05-12-2023	50% PROGRESS SUBMITTAL	PM
B		03-23-2023	60% PROGRESS SUBMITTAL	PM
A		06-03-2022	30% PROGRESS SUBMITTAL	PM



PROJECT MANAGER:	DATE
FOR REDUCED PLANS - ORIGINAL SCALE IS IN INCHES	

DEPICTION OF MONUMENTS:	DATE
SURVEY PARTY CHIEF	
WATERSHED REVIEW:	DATE

SUBMITTED:	DATE
SUPERVISING CIVIL ENGINEER	EXP.
APPROVED:	DATE
CITY ENGINEER	EXP.

DESIGN	B.H.	HORIZ.	AS SHOWN
DRAWN	P.W.	VERT.	
CHECK	P.M.	BOOK	
AS BUILT		DATE	05/12/23



BERKELEY MARINA DOCK REPLACEMENT (D-E)
CITY OF BERKELEY, ALAMEDA COUNTY, CALIFORNIA
FIRE PROTECTION PLAN NEW WORK
DOCK "D & E"

PLAN	FILE
FP-201	SHEET 42 OF 51

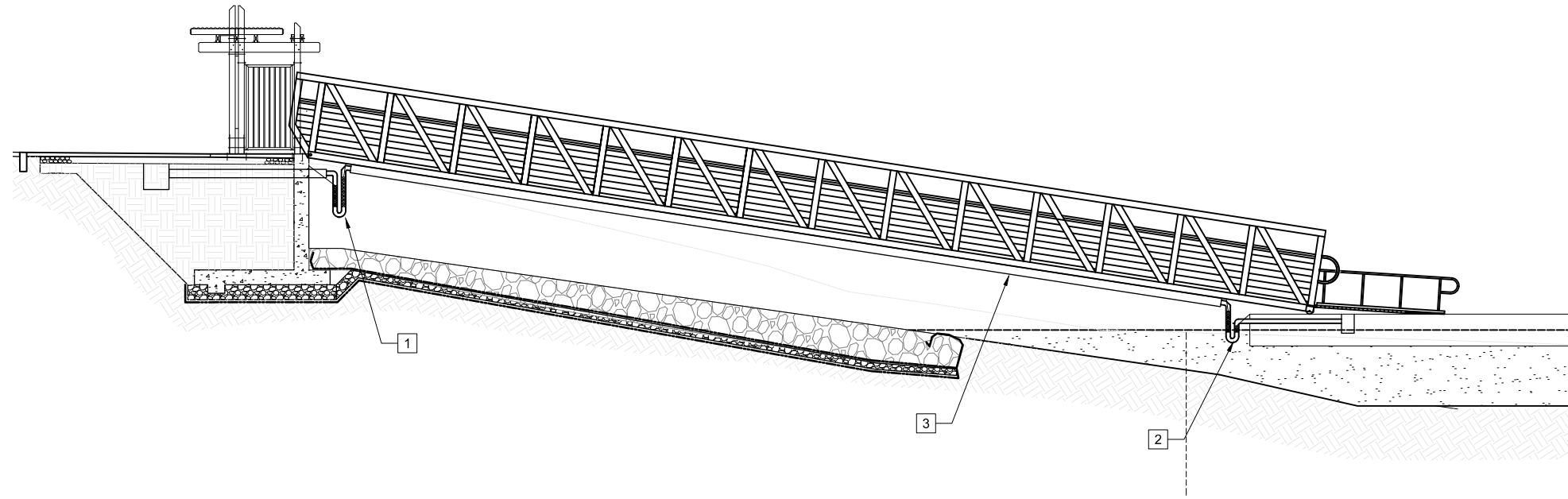

GANGWAY SECTION

SCALE: 1" = 2'-0"

A
FP-301

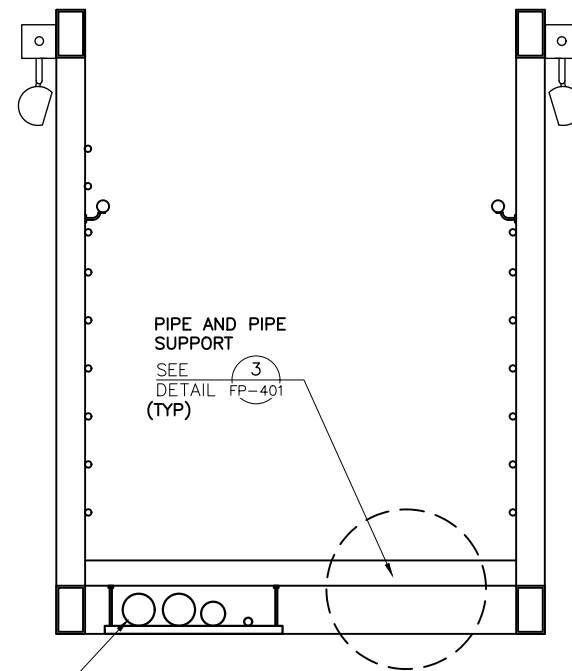

ELECTRICAL CONDUITS AND SUPPORT, REFER TO ELECTRICAL DWGS

GANGWAY SECTION

SCALE: 1" = 1'-0"

B
FP-301

SHEET NOTES:

1. SEE SHEET FP001 FOR FIRE PROTECTION GENERAL NOTES, ABBREVIATIONS AND LEGEND.
2. REFER TO STRUCTURAL DRAWINGS FOR DOCK STRUCTURES.
3. PROVIDE 316 SS HANGERS, PIPE CLAMPS AND BRACING FOR PIPING IN ACCORDANCE WITH CPC AND CBC. ANCHORS AND BOLTING SHALL BE 316 SS.

KEY NOTES:

- 1 PROVIDE FLEX LOOP CONNECTOR ON 3" FIREWATER BELOW GANGWAY AT INTERSECTION BETWEEN GANGWAY AND SHORE STRUCTURE
- 2 PROVIDE (N) FLEX LOOP CONNECTOR ON WATER PIPE UNDER GANGWAY, AT INTERSECTION OF GANGWAY AND DOCK.
- 3 4"Ø FIREWATER PIPELINE ALONG UNDERSIDE OF GANGWAY.

DRAFT 90% Submittal

PLOTTED BY: MINH TRAN PLOT DATE: 05/20/23 4:26:14 PM

REVISION	MARK	DATE	DESCRIPTION	APPROVAL
A		05-12-2023	90% PROGRESS SUBMITTAL	PM



PROJECT MANAGER: _____ DATE _____
 SURVEY PARTY CHIEF _____
 WATERSHED REVIEW: _____ DATE _____

DEPICTION OF MONUMENTS: _____ DATE _____
 SURVEY PARTY CHIEF _____
 WATERSHED REVIEW: _____ DATE _____

SUBMITTED: _____ DATE _____
 SUPERVISING CIVIL ENGINEER _____
 APPROVED: _____ DATE _____
 CITY ENGINEER _____

DESIGN: _____ B.H. _____
 DRAWN: _____ P.W. _____
 CHECK: _____ P.M. _____
 AS BUILT _____ DATE: 05/12/23



BERKELEY MARINA DOCK REPLACEMENT (D-E)
 CITY OF BERKELEY, ALAMEDA COUNTY, CALIFORNIA
 FIRE PROTECTION SECTIONS - SHEET 1 OF 2

PLAN _____
 FILE _____
 FP-301
 SHEET 43 OF 51

SHEET NOTES:

1. SEE SHEET FP001 FOR FIRE PROTECTION GENERAL NOTES, ABBREVIATIONS AND LEGEND.
2. REFER TO STRUCTURAL DRAWINGS FOR DOCK STRUCTURES.
3. PROVIDE 316 SS HANGERS, PIPE CLAMPS AND BRACING FOR PIPING IN ACCORDANCE WITH CPC AND CBC. ANCHORS AND BOLTING SHALL BE 316 SS.

KEY NOTES:

1. 3"Ø FIREWATER PIPELINE ALONG UNDERSIDE OF WALKWAY WALER. ANCHOR PIPE TO BOTTOM OF WALER.

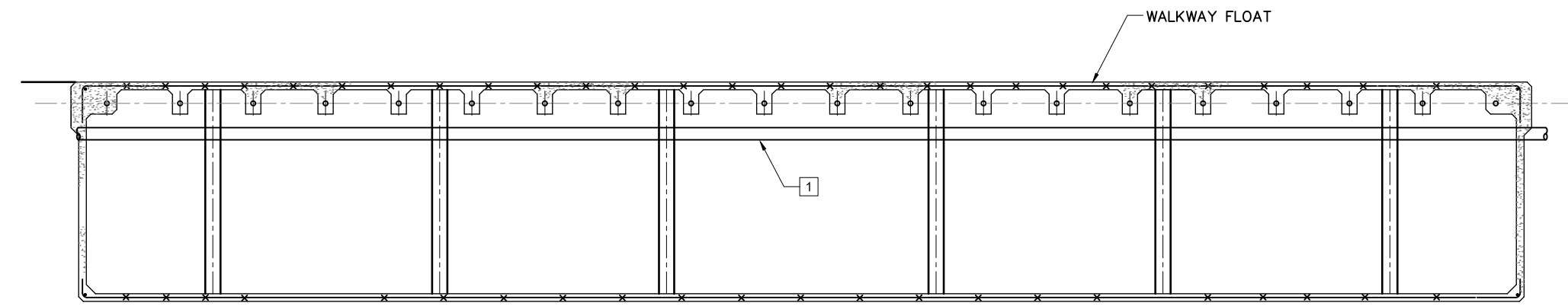

WALKWAY SECTION

SCALE: 1" = 1'-0"

A
FP-302

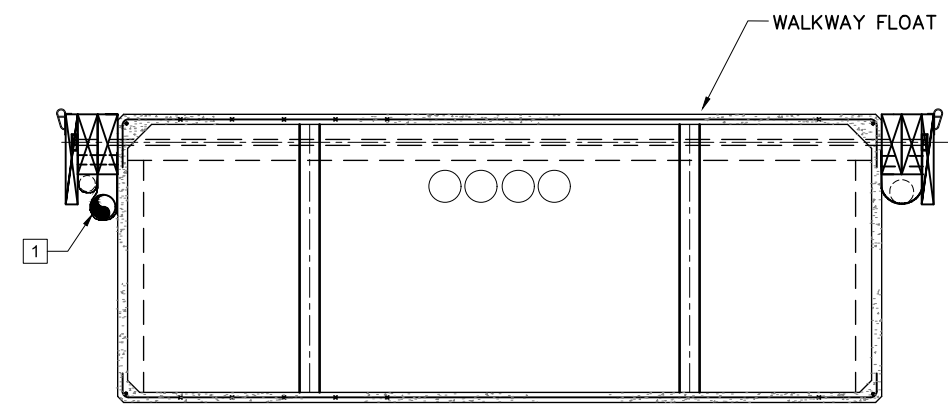

WALKWAY SECTION

SCALE: 1" = 1'-0"

B
FP-302

DRAFT 90% Submittal

REVISION	MARK	DATE	DESCRIPTION	APPROVAL
A		05-12-2023	30% PROGRESS SUBMITTAL	PM



PROJECT MANAGER: _____ DATE _____

DEPICTION OF MONUMENTS: _____ DATE _____

SURVEY PARTY CHIEF _____

WATERSHED REVIEW: _____ DATE _____

0 1 2 3
FOR REDUCED PLANS - ORIGINAL SCALE IS IN INCHES

SUBMITTED: _____ DATE _____

SUPERVISING CIVIL ENGINEER _____

APPROVED: _____ DATE _____

CITY ENGINEER _____

DESIGN: _____ B.H. _____

DRAWN: _____ P.W. _____

CHECK: _____ P.M. _____

AS BUILT _____

HORIZ.: _____ AS SHOWN _____

VERT.: _____

BOOK _____

DATE: 05/12/23



BERKELEY MARINA DOCK REPLACEMENT (D-E)
CITY OF BERKELEY, ALAMEDA COUNTY, CALIFORNIA

FIRE PROTECTION
SECTIONS - SHEET 2 OF 2

PLAN _____

FILE _____

FP-302

SHEET 44 OF 51

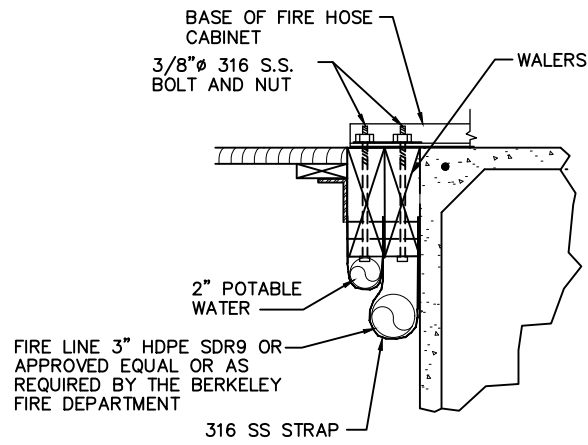

FIRE CABINET SUPPORT DETAIL

SCALE: NTS

1
FP-401

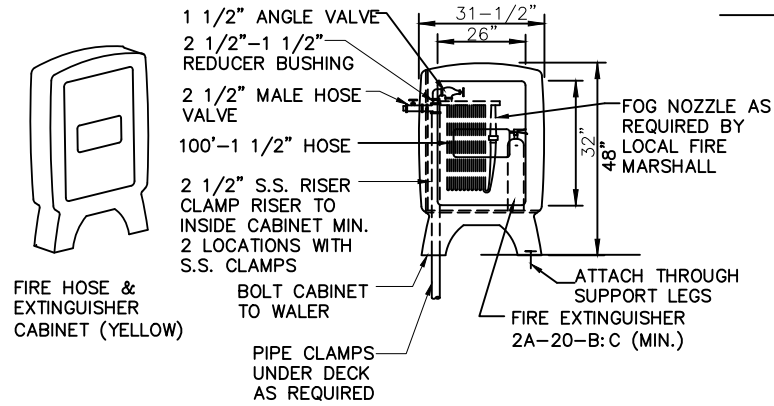

FIRE HOSE CABINET DETAIL

SCALE: NTS

2
FP-401

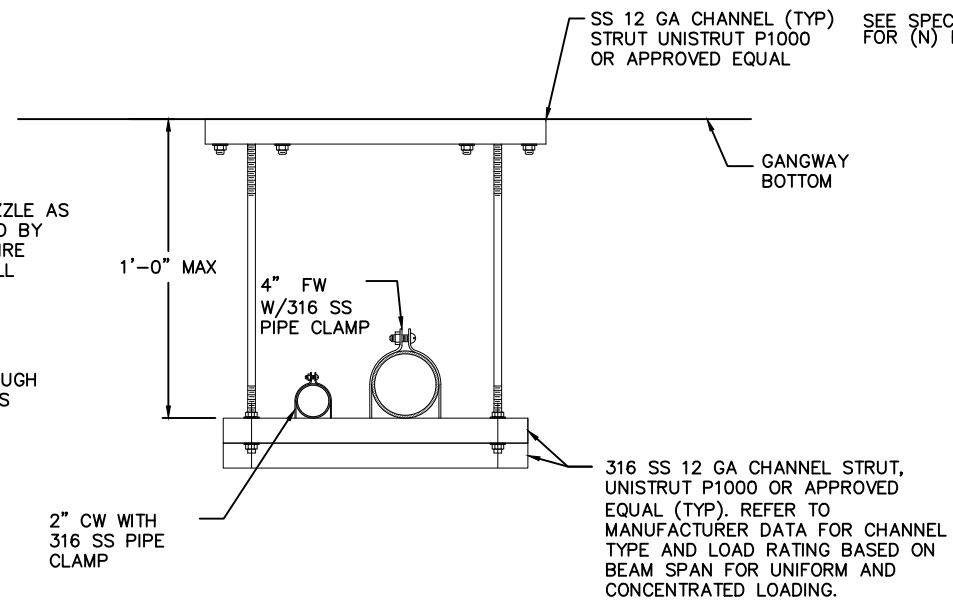

GANGWAY PIPE SUPPORT DETAIL

SCALE: NTS

3
FP-401

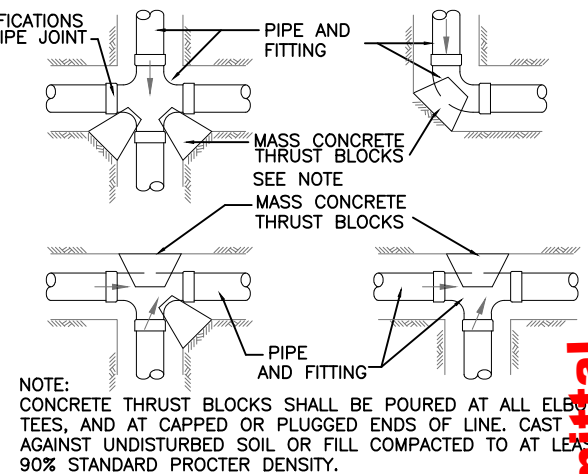

THRUST BLOCK LOCATION DETAIL

SCALE: NTS

NOTE: CONCRETE THRUST BLOCKS SHALL BE POURED AT ALL ELBOW TEES, AND AT CAPPED OR PLUGGED ENDS OF LINE. CAST AGAINST UNDISTURBED SOIL OR FILL COMPACTED TO AT LEAST 90% STANDARD PROCTER DENSITY.

PIPE SIZE	BEARING AREA* OF THRUST BLOCKS			
	90° ELL.-SF	45° ELL.-SF	TEES-SF	PLUG/CAP-SF
4	2	1.5	2	1.5
6	6	3	4	4
8	8	5	7	7
10	8	8	8	8

* FOR PIPE LINE PRESSURES OF 150 PSI IN 1500 PSF BEARING CAPACITY

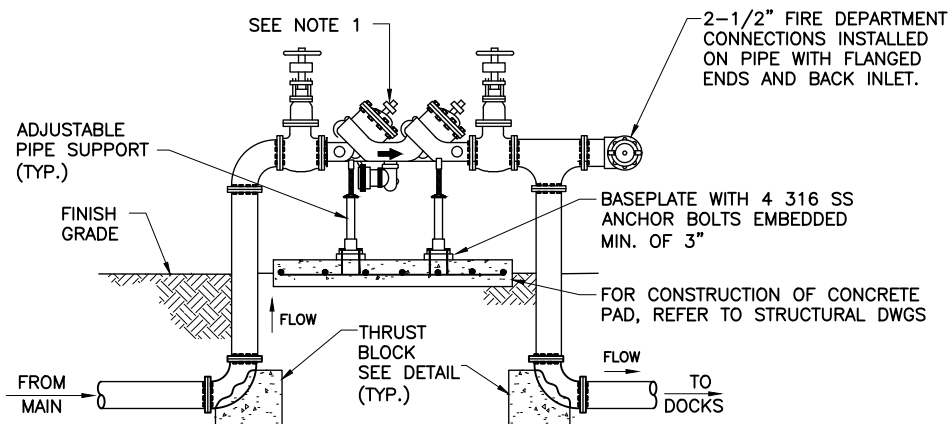

FIRE WATER BACKFLOW PREVENTER ASSEMBLY

SCALE: NTS

5
FP-401

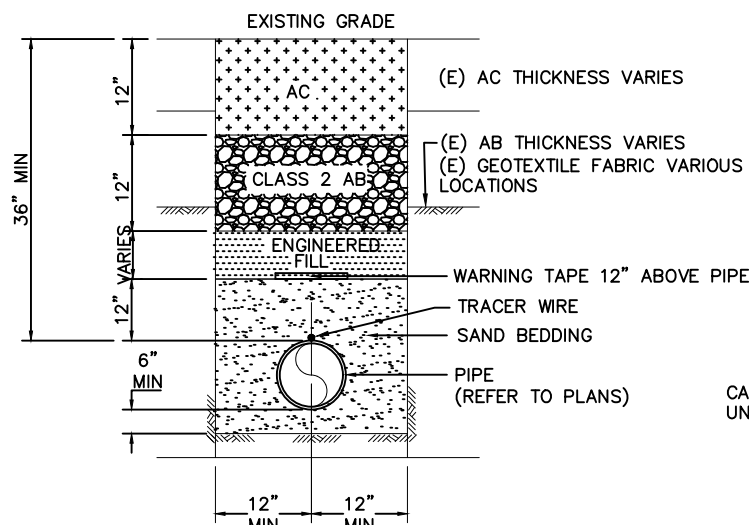

TYPICAL FIREWATER TRENCH DETAIL

SCALE: NTS

6
FP-401

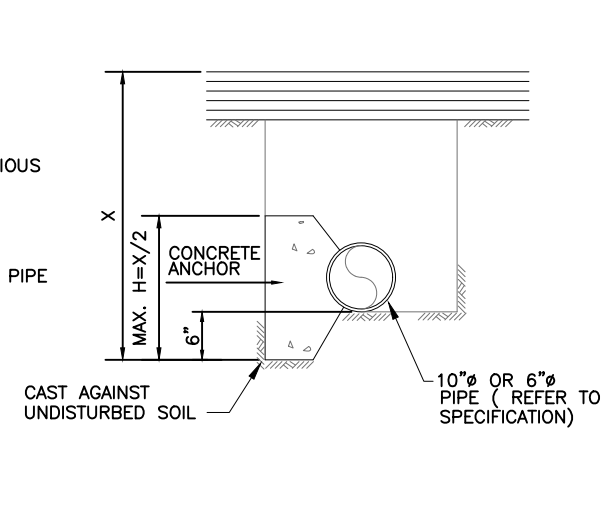

TYPICAL ANCHOR BLOCK FOR PIPE

SCALE: NTS

7
FP-401

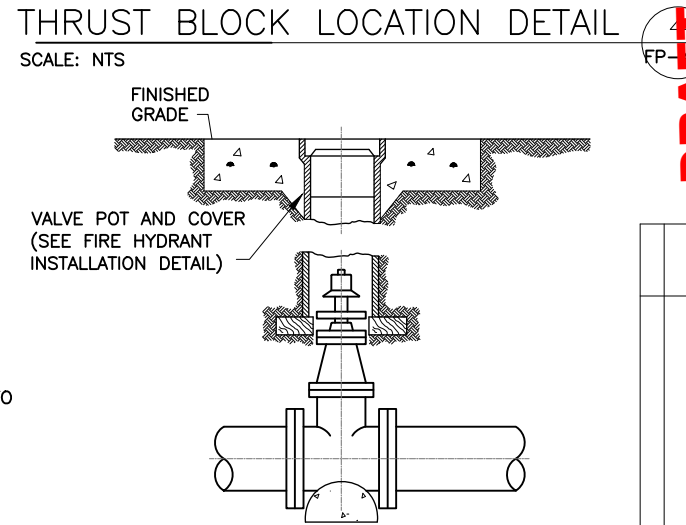

TYPICAL VALVE DETAIL

SCALE: NTS

8
FP-401

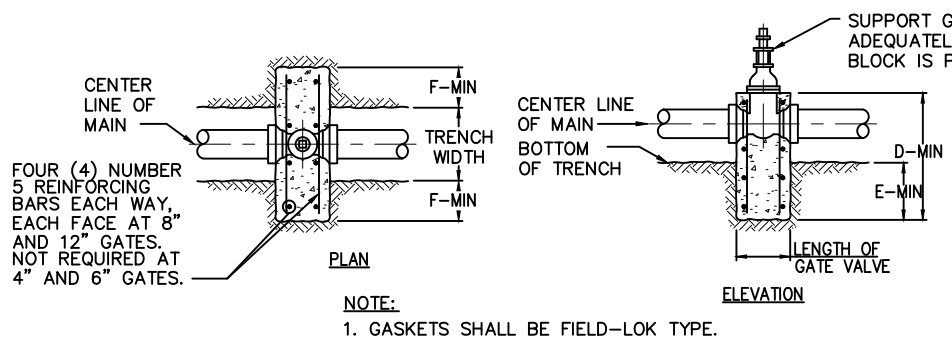

THRUST BLOCK AT GATE VALVES

SCALE: NTS

9
FP-401

SIZE (IN)	"D" (IN)	"E" (IN)	"F" (IN)
4	12	4	6
6	18	8	6
8	24	12	6
12	36	18	12

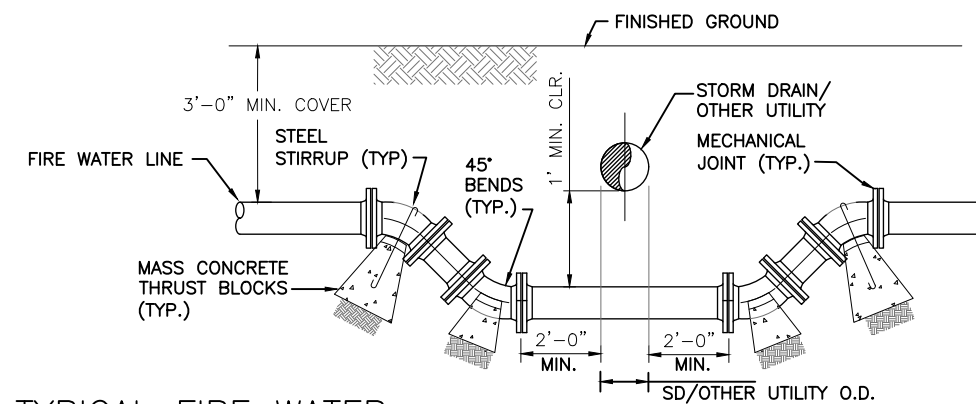

TYPICAL FIRE WATER LINE CROSSING STORMDRAIN/OTHER UTILITIES DETAIL

SCALE: NTS

10
FP-401



PROJECT MANAGER: _____ DATE _____
 SURVEY PARTY CHIEF: _____ DATE _____
 WATERSHED REVIEW: _____ DATE _____

DEPICTION OF MONUMENTS: _____ DATE _____
 SUBMITTED: _____ DATE _____
 SUPERVISING CIVIL ENGINEER: _____ DATE _____
 APPROVED: _____ DATE _____
 CITY ENGINEER: _____ DATE _____

DESIGN: _____ DATE _____
 DRAWN: _____ DATE _____
 CHECK: _____ DATE _____
 AS BUILT: _____ DATE _____

HORIZ. AS SHOWN
 VERT. _____
 BOOK _____
 DATE 05/12/23



BERKELEY MARINA DOCK REPLACEMENT (D-E)
 CITY OF BERKELEY, ALAMEDA COUNTY, CALIFORNIA
 FIRE PROTECTION DETAILS

PLAN _____
 FILE _____
 SHEET 45 OF 51

DRAFT 90% Submittal

NO.	DATE	DESCRIPTION	APPROVAL

PLUMBING LEGEND		
SYMBOL	ABBR.	DESCRIPTION
	(E)	EXISTING PIPE
	(N)	NEW PIPE
	CW	DOMESTIC COLD WATER PIPE
	D	DRAIN PIPE
		SLOPE
		ELBOW DOWN
		ELBOW UP
		ELBOW DOWN
		ELBOW UP
		TEE DOWN
		TEE UP
	RED	REDUCER
	POC	POINT OF CONNECTION
	POD	POINT OF DEMOLITION
	BV	BALL VALVE - FULL PORT
	HB	HOSE BIB
		VALVE
	PRV	PRESSURE REDUCING VALVE
	M	METER
	WHA	WATER HAMMER ARRESTER
	GAL	GALLON
	GPH	GALLON PER HOUR
	IN	INCH
	DIA	DIAMETER
	FT	FEET
	MSS SP-58	PIPE HANGERS AND SUPPORTS - MATERIALS, DESIGN AND MANUFACTURE
	MSS SP-69	PIPE HANGERS AND SUPPORTS - SELECTION AND APPLICATION
	BG	BELOW GROUND
		SECTION REFERENCE SYMBOL
		SECTION IDENTIFICATION LETTER SHEET NUMBER ON WHICH SECTION IS DRAWN SHEET NUMBER(S) FROM WHICH SECTION IS TAKEN

- ### GENERAL PLUMBING NOTES
- EXAMINE ALL DRAWINGS & FIELD VERIFY ELECTRICAL AND PLUMBING CONDITIONS PRIOR TO WORK & REPORT ANY DISCREPANCIES IN WRITING TO CONSTRUCTION MANAGER AS NOTED. VERIFY AT PROJECT SITE EXACT SIZE, LOCATION, INVERT ELEVATION, AND CLEARANCE OF ALL EXISTING SERVICES BEING EXTENDED, RELOCATED, OR REMOVED.
 - THE DRAWINGS ARE DIAGRAMMATIC & SHALL NOT BE SCALED TO DETERMINE EXACT LOCATION OF PLUMBING & EQUIPMENT.
 - ADVISE THE ENGINEER IN WRITING IN THE EVENT A CONFLICT OCCURS BETWEEN THE REQUIREMENTS OF THE CONTRACT DOCUMENTS AND ACTUAL FIELD CONDITIONS. THE CONTRACTOR SHALL BEAR ALL COSTS FOR RELOCATION OF EQUIPMENT PIPING, ETC., FROM FAILURE TO PROPERLY COORDINATE INSTALLATIONS AND ADVISE OF THE CONFLICT IN WRITING PRIOR TO INSTALLATION.
 - CONTRACTOR IS TO MAINTAIN RECORDED "AS-BUILT" INFORMATION ON ALL EXISTING SERVICES UNCOVERED DURING CONSTRUCTION AND ALL NEW SERVICES BEING INSTALLED. "AS-BUILT" INFORMATION SHALL BE CLEARLY MARKED IN COLORED PENCIL ON A BLUE PRINT OF CONTRACT DRAWING. RECORDED INFORMATION SHALL INCLUDE ROUTING AND INVERT ELEVATIONS. AT THE COMPLETION OF THE CONTRACT, THE CONTRACTOR SHALL TURN RECORDED "AS-BUILT" INFORMATION OVER TO THE ENGINEER.
 - PLANS ARE BASED ON ANTICIPATED PIPING AND EQUIPMENT SIZE AND CONFIGURATION. CONTRACTOR SHALL MODIFY ARRANGEMENT TO SUIT ACTUAL PURCHASED PIPING AND EQUIPMENT AS REQUIRED FOLLOWING THE CRITERIA ESTABLISHED BY THE PLANS AND SPECIFICATIONS. DEPARTURES FROM THE CONTRACT DRAWINGS AND SPECIFICATIONS RESULT FROM CHANGES IN EQUIPMENT SIZES AND CONFIGURATIONS, OR RE-ARRANGEMENTS TO ACCOMMODATE FIELD CONDITIONS, SHALL BE SUBMITTED IN DETAIL FOR THE ENGINEER'S APPROVAL.
 - SECURELY FASTEN ALL PIPING TO THE STRUCTURE CONSTRUCTION BY MEANS OF HANGERS, SUPPORTS, GUIDES, ANCHORS, AND SWAY BRACES TO MAINTAIN PIPE ALIGNMENT, TO PREVENT SAGGING, AND TO PREVENT NOISE AND EXCESSIVE STRAIN ON PIPING DUE TO MOVEMENT UNDER OPERATING CONDITIONS. ALL PLUMBING EQUIPMENT SHALL BE BRACED OR ANCHORED TO RESIST A HORIZONTAL FORCE ACTING IN ANY DIRECTION USING THE FOLLOWING CRITERIA: THE TOTAL DESIGN LATERAL SEISMIC FORCE SHALL BE DETERMINED FROM CBC 1613A. FORCES SHALL BE APPLIED IN THE HORIZONTAL DIRECTIONS THAT WILL RESULT IN THE MOST CRITICAL LOADING FOR DESIGN. WHERE ANCHORAGE DETAILS AND LOCATIONS ARE NOT SPECIFICALLY SHOWN ON THE PLANS, THE FIELD INSTALLATION SHALL BE SUBJECT TO REVIEW AND APPROVAL OF THE ENGINEER OF RECORD. SUPPORTS FOR ALL PIPING SHALL BE IN ACCORDANCE WITH LATEST SMACNA GUIDELINES FOR SEISMIC RESTRAINTS OF MECHANICAL SYSTEMS AND PIPING SYSTEMS AND MSS SP-58 AND SP-69.
 - ALL PIPES AND FITTINGS UTILIZED IN WATER SUPPLY SYSTEMS SHALL ALSO CONFORM TO NSF 61 AS REQUIRED BY THE LATEST CALIFORNIA PLUMBING CODE.
 - COORDINATE INSTALLATION OF ALL EQUIPMENT, PIPING AND ACCESSORIES WITH OTHER TRADES PRIOR TO INSTALLATION. CONTRACTOR SHALL COORDINATE EXACT LOCATION OF CONTROL DEVICES AND VALVE BOXES PRIOR TO INSTALLATION.
 - ARRANGE ALL PIPING WITHIN STRUCTURES NEATLY ALONG WALLS AND/OR IN NEAT, HORIZONTAL GROUPS AND MAINTAIN REQUIRED SLOPES.
 - PROVIDE A SUPPORT CLAMP OR HANGER NOT MORE THAN 12-INCHES FROM THE POINT OF CHANGE OF DIRECTION OF A PIPE RUN IN BOTH HORIZONTAL AND VERTICAL PLANE.
 - PIPE HANGERS SHALL BE DESIGNED TO SUPPORT THE WEIGHT OF THE PIPE AND THE WEIGHT OF THE CONTENTS OF THE PIPE. PROVIDE ADEQUATE SUPPORT FOR ALL PARTS OF THE PIPING SYSTEM. PIPE HANGERS SPACING AND ROD SIZES SHALL BE IN ACCORDANCE WITH CALIFORNIA PLUMBING CODE 313. REFER TO DETAILS ON DRAWINGS FOR HANGERS AND ATTACHMENTS.
 - CONNECTION BETWEEN DISSIMILAR MATERIAL PIPES SHALL BE MADE WITH DIELETRIC ISOLATING UNIONS, OR GASKETED FLANGES WITH ISOLATED THROUGH BOLTS.
 - PERFORM ALL INLET AND DISCHARGE PIPING DESIGN TO PROVIDE SMOOTH FLOW WITH UNIFORM VELOCITY OVER THE ENTIRE AREA OF PIPING.
 - CONTRACTOR SHALL PROTECT THE PIPING TO PREVENT ENTRY OF DIRT AND ANY OTHER FOREIGN MATERIAL DURING THE INSTALLATION.
 - UNIONS SHALL BE PROVIDED FOR EACH SCREW-TYPE VALVE AND EQUIPMENT CONNECTION.
 - ALL WORK SHALL BE PERFORMED IN ACCORDANCE WITH THE LATEST CALIFORNIA BUILDING CODE AND CALIFORNIA PLUMBING CODE.

BACKFLOW PREVENTER						
EQPM ID	LOCATION	AREA SERVE	TYPE	SIZE	SERVICE	REMARKS
				IN.		
BFP-1	OUTDOORS	REFER TO DRAWINGS	REDUCED PRESSURE ZONE	2	DOMESTIC COLD WATER	SEE NOTES

NOTES:

- AWWA C511, BRONZE BODY, PROVIDE WITH TWO POSITIVE SEATING CHECK VALVES, HYDRAULICALLY DEPENDENT DIFFERENTIAL RELIEF VALVE, AND BACKSIPHONAGE. PROVIDE WITH OUTDOOR CORROSION RESISTANT COATED VANDAL PROOF CAGE ANCHORED TO CONCRETE PAD.

DRAFT 90% Submittal

REVISION	MARK	DATE	DESCRIPTION
C		05-12-2023	50% PROGRESS SUBMITTAL
B		03-23-2023	60% PROGRESS SUBMITTAL
A		06-03-2022	30% PROGRESS SUBMITTAL
			APPROVAL



PROJECT MANAGER: _____ DATE _____
 SURVEY PARTY CHIEF _____
 WATERSHED REVIEW: _____ DATE _____

DEPICTION OF MONUMENTS: _____ DATE _____
 SUPERVISING CIVIL ENGINEER _____
 APPROVED: _____ DATE _____
 CITY ENGINEER _____

DESIGN: _____ B.H. _____
 DRAWN: _____ P.W. _____
 CHECK: _____ P.M. _____
 AS BUILT: _____ DATE: 05/12/23

HORIZ.: AS SHOWN
 VERT.: _____
 BOOK: _____



BERKELEY MARINA DOCK REPLACEMENT (D-E)
 CITY OF BERKELEY, ALAMEDA COUNTY, CALIFORNIA
 PLUMBING GENERAL NOTES, LEGEND AND ABBREVIATIONS

PLAN _____
 FILE _____
 P-001
 SHEET 46 OF 51

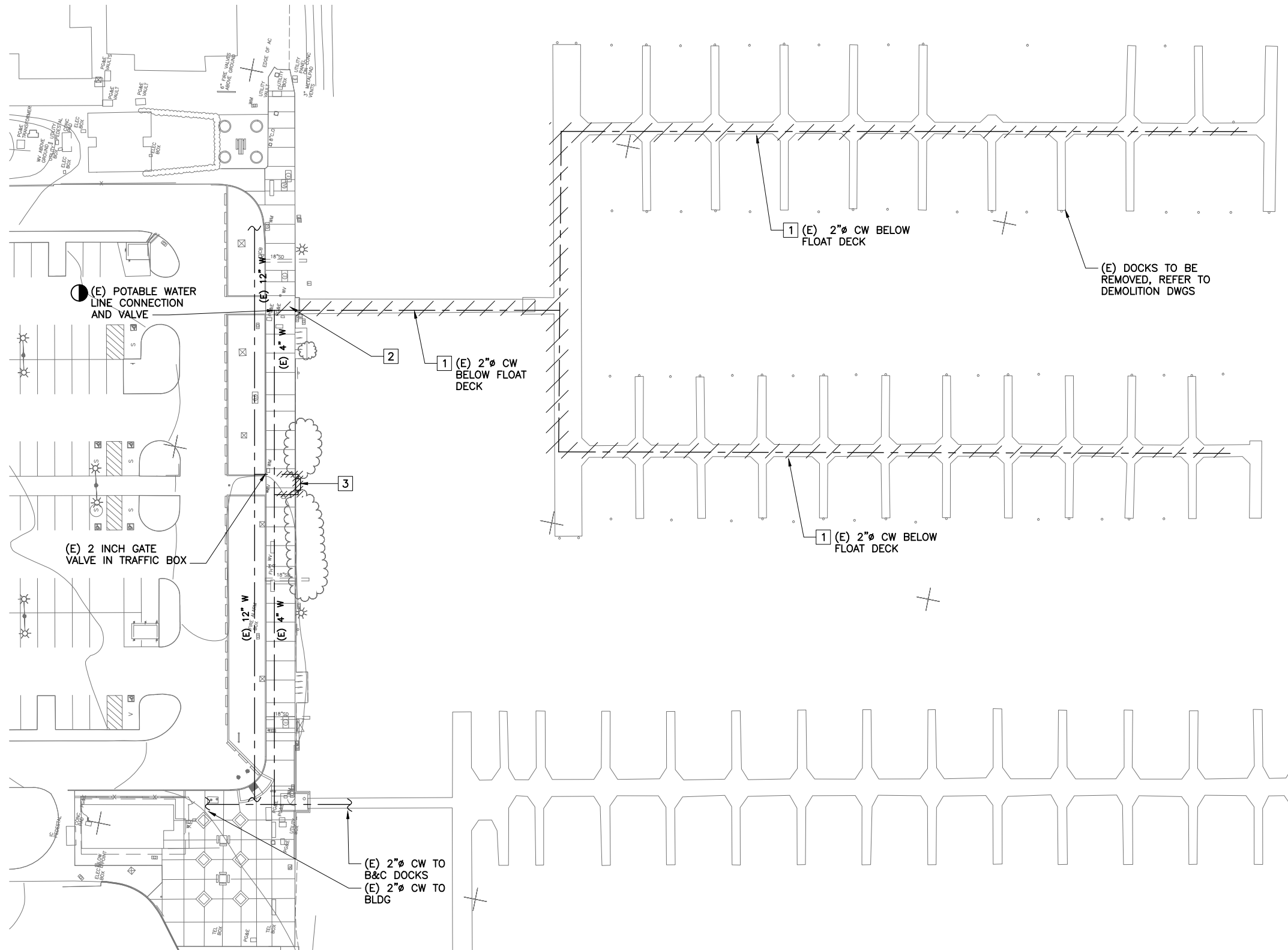

PLUMBING PLAN DEMOLITION WORK - DOCK 'D&E'
 SCALE: 1" = 30'-0"

SHEET NOTES:

1. SEE SHEET P001 FOR PLUMBING PROTECTION GENERAL NOTES, ABBREVIATIONS AND LEGEND.
2. CONTRACTOR SHALL VISIT THE SITE TO FULLY ASSESS THE EXTENT OF NEW WORK PRIOR TO BIDDING.
3. COORDINATE ALL WORK AND SHUTDOWNS WITH OWNER.

KEY NOTES:

- 1 DEMOLISH ALL (E) DOCK POTABLE WATER PIPING, HOSE BIBS, FITTINGS, PIPE SUPPORTS AND APPURTENANCES.
- 2 DEMOLISH (E) POTABLE WATER UNDERGROUND TO (E) WATER VALVE AND CAP AT DOWNSTREAM SIDE OF WATER VALVE. FILL TRENCH AND RESURFACE TO MATCH ADJACENT SURFACING.
- 3 DEMOLISH (E) BACKFLOW PREVENTER ASSEMBLY AND RECONNECT PIPING FOR CONTINUATION OF THE WATER SERVICE AT NEW BACKFLOW PREVENTER LOCATION. REFER TO CIVIL DWGS FOR REPAIR OF THE DISTURBED SURFACE.

DRAFT 90% Submittal

PLOTTED BY: MINH TRAN PLOT DATE: 5/20/23 4:26:55 PM

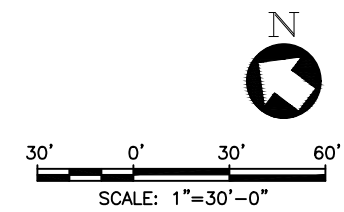

REVISION	MARK	DATE	DESCRIPTION	APPROVAL
C		05-12-2023	90% PROGRESS SUBMITTAL	PM
B		03-27-2023	60% PROGRESS SUBMITTAL	PM
A		08-03-2022	30% PROGRESS SUBMITTAL	PM



PROJECT MANAGER: _____ DATE _____
 SURVEY PARTY CHIEF _____
 WATERSHED REVIEW: _____ DATE _____
 FOR REDUCED PLANS - ORIGINAL SCALE IS IN INCHES

DEPICTION OF MONUMENTS: _____ DATE _____
 SURVEY PARTY CHIEF _____
 WATERSHED REVIEW: _____ DATE _____

SUBMITTED: _____ DATE _____
 R.C.E. _____
 SUPERVISING CIVIL ENGINEER _____
 EXP. _____
 APPROVED: _____ DATE _____
 R.C.E. _____
 CITY ENGINEER _____
 EXP. _____

DESIGN: _____ B.H. _____
 DRAWN: _____ P.W. _____
 CHECK: _____ P.M. _____
 AS BUILT _____
 DATE: 05/12/23



BERKELEY MARINA DOCK REPLACEMENT (D-E)
 CITY OF BERKELEY, ALAMEDA COUNTY, CALIFORNIA
 PLUMBING PLAN DEMOLITION WORK
 DOCK "D & E"

PLAN _____
 FILE _____
 P-101
 SHEET 47 OF 51

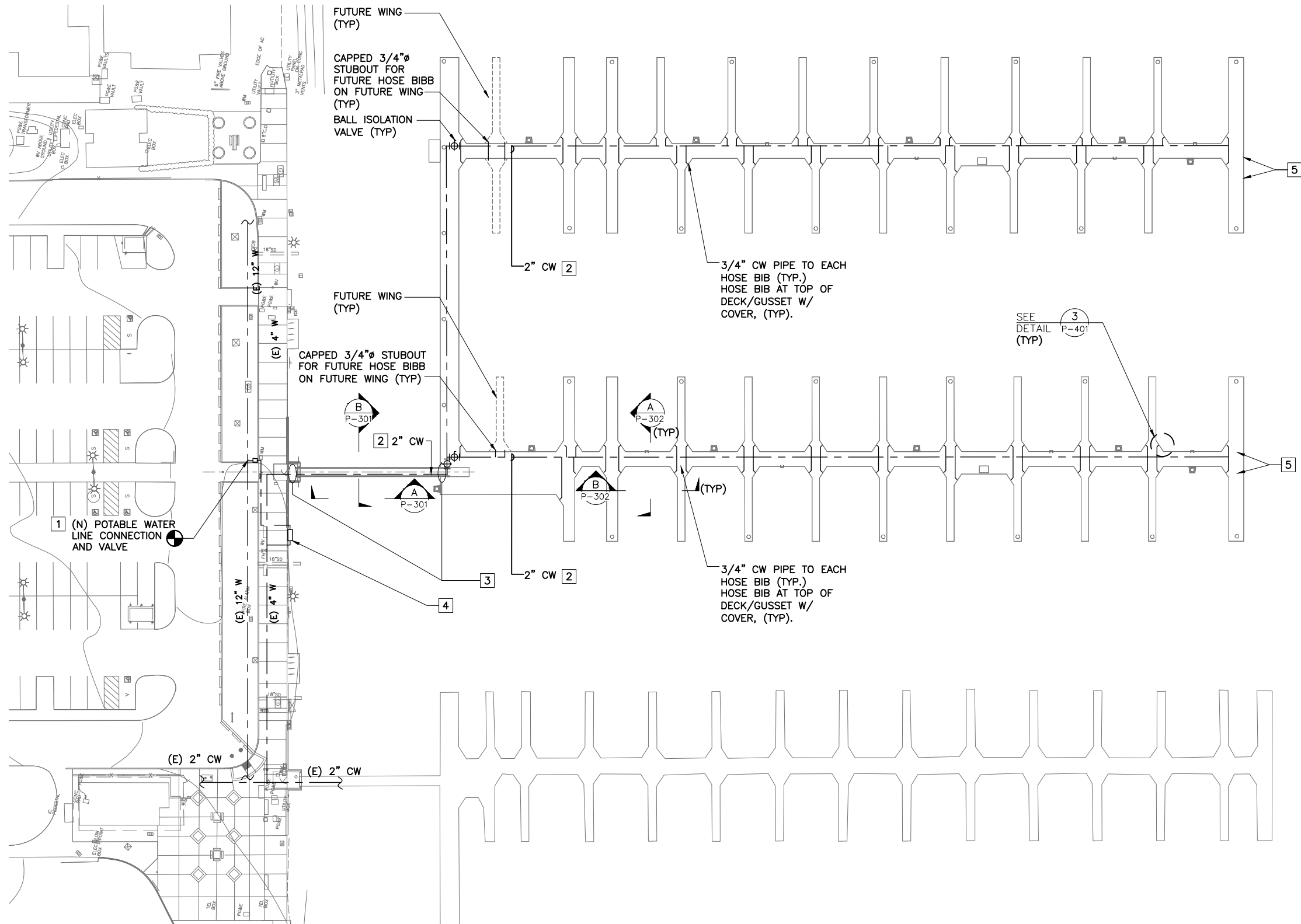

SHEET NOTES:

1. SEE SHEET P001 FOR PLUMBING PROTECTION GENERAL NOTES, ABBREVIATIONS AND LEGEND.
2. CONTRACTOR SHALL VISIT THE SITE TO FULLY ASSESS THE EXTENT OF NEW WORK PRIOR TO BIDDING.
3. COORDINATE ALL WORK AND SHUTDOWNS WITH OWNER.
4. REFER TO STRUCTURAL DRAWINGS FOR DOCK STRUCTURES.
5. PROVIDE 316 SS HANGERS, PIPE CLAMPS AND BRACING FOR PIPING IN ACCORDANCE WITH CPC AND CBC. ANCHORS AND BOLTING SHALL BE 316 SS.
6. (N) POTABLE WATER LINES SHALL BE SCHEDULE 80 PVC.

KEY NOTES:

- 1 CONTRACTOR TO FIELD VERIFY LOCATION OF EXISTING LANDSIDE WATERLINE AND PROVIDE NEW POTABLE WATER ISOLATION VALVE IN SIDEWALK NEAR NEW GANGWAY.
- 2 MAIN LINE WATER LINE SHALL BE GLUED. ABOVEGROUND WATER LINES TO HOSE BIBS SHALL BE THREADED NIPPLES AND FITTINGS. ALL OTHER LATERAL CONNECTIONS SHALL BE GLUED.
- 3 PROVIDE (N) FLEX CONNECTOR ON WATER PIPE UNDER GANGWAY, AT INTERSECTION OF GANGWAY AND DOCK.
- 4 PROVIDE (N) 2" REDUCED PRINCIPLE BACKFLOW PREVENTER ASSEMBLY INCLUDING PAINTED CAGE WITH LOCK FOR SECURING THE EQUIPMENT. CONNECT PIPING TO THE UNDERGROUND PIPING. ADD CONCRETE PAD TO SECURE THE CAGE.
- 5 PROVIDE (N) HOSE BIB.

PLUMBING PLAN NEW WORK - DOCK 'D&E'

SCALE: 1" = 30'-0"

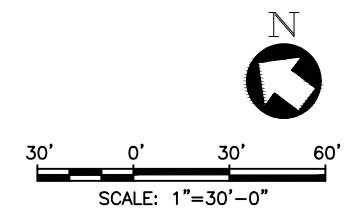

PROJECT MANAGER:	DATE	DEPICTION OF MONUMENTS:	DATE
		SURVEY PARTY CHIEF	
		WATERSHED REVIEW:	DATE

SUBMITTED:	DATE	DESIGN	B.H.	HORIZ.	AS SHOWN
		DRAWN	P.W.	VERT.	
		CHECK	P.M.	BOOK	
		AS BUILT		DATE	05/12/23

SUPERVISING CIVIL ENGINEER	DATE	CITY ENGINEER	DATE

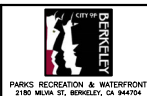

BERKELEY MARINA DOCK REPLACEMENT (D-E)
CITY OF BERKELEY, ALAMEDA COUNTY, CALIFORNIA
PLUMBING PLAN NEW WORK
DOCK "D & E"

REVISION	MARK	DATE	DESCRIPTION	APPROVAL
C		05-12-2023	50% PROGRESS SUBMITTAL	PM
B		03-23-2023	60% PROGRESS SUBMITTAL	PM
A		08-03-2022	30% PROGRESS SUBMITTAL	PM

PLAN _____
FILE _____
P-201
SHEET 48 OF 51

DRAFT 90% Submittal

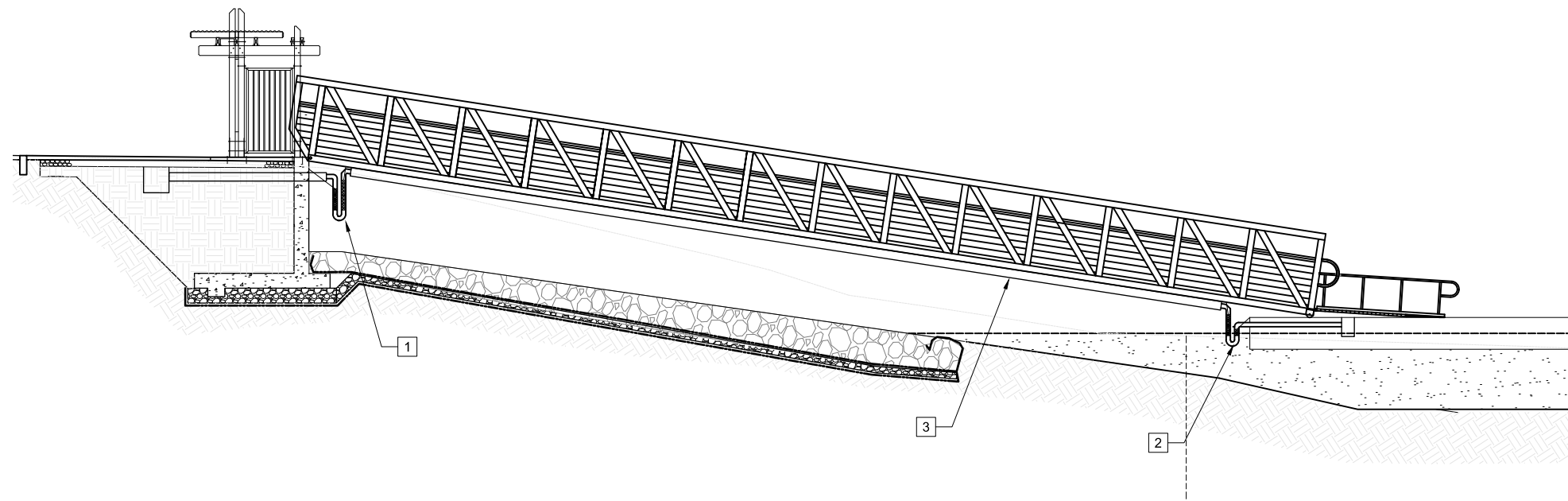

GANGWAY SECTION

SCALE: 1" = 2'-0"

A
P-301

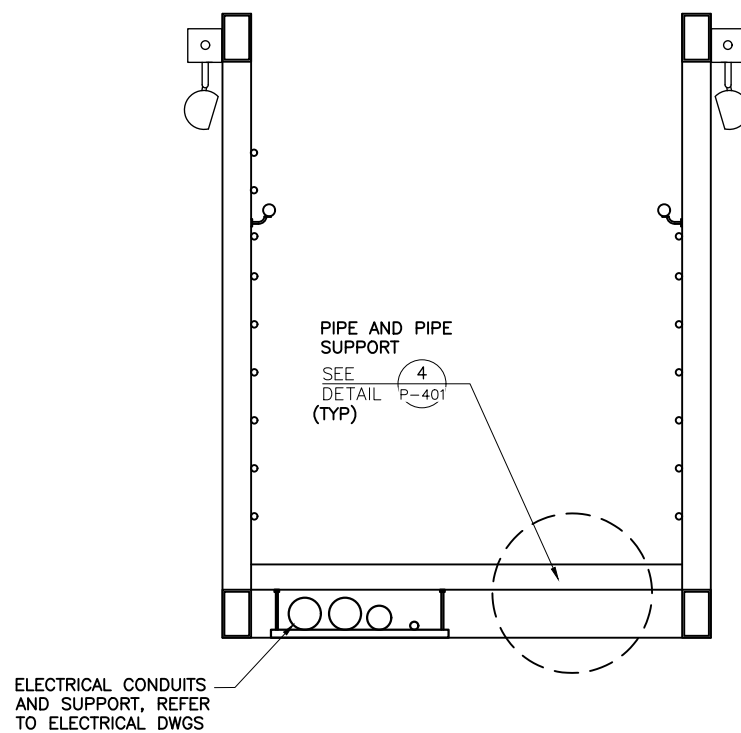

GANGWAY SECTION

SCALE: 1" = 1'-0"

B
P-301

SHEET NOTES:

1. SEE SHEET P001 FOR PLUMBING PROTECTION GENERAL NOTES, ABBREVIATIONS AND LEGEND.
2. REFER TO STRUCTURAL DRAWINGS FOR DOCK STRUCTURES.
3. PROVIDE 316 SS HANGERS, PIPE CLAMPS AND BRACING FOR PIPING IN ACCORDANCE WITH CPC AND CBC. ANCHORS AND BOLTING SHALL BE 316 SS.

KEY NOTES:

- 1 PROVIDE FLEX LOOP CONNECTOR ON 2" CW BELOW GANGWAY AT INTERSECTION BETWEEN GANGWAY AND SHORE STRUCTURE
- 2 PROVIDE (N) FLEX LOOP CONNECTOR ON WATER PIPE UNDER GANGWAY, AT INTERSECTION OF GANGWAY AND DOCK.
- 3 2"Ø POTABLE CW PIPELINE ALONG UNDERSIDE OF GANGWAY.

DRAFT 90% Submittal

REVISION	MARK	DATE	DESCRIPTION
A		05-01-2023	90% PROGRESS SUBMITTAL
			APPROVAL



PROJECT MANAGER: _____ DATE: _____
 SURVEY PARTY CHIEF: _____
 WATERSHED REVIEW: _____ DATE: _____

DEPICTION OF MONUMENTS: _____ DATE: _____
 SURVEY PARTY CHIEF: _____
 WATERSHED REVIEW: _____ DATE: _____

SUBMITTED: _____ DATE: _____
 SUPERVISING CIVIL ENGINEER: _____
 APPROVED: _____ DATE: _____
 CITY ENGINEER: _____

DESIGN: _____ B.H. _____
 DRAWN: _____ P.W. _____
 CHECK: _____ P.M. _____
 AS BUILT: _____ DATE: 05/12/23



BERKELEY MARINA DOCK REPLACEMENT (D-E)
 CITY OF BERKELEY, ALAMEDA COUNTY, CALIFORNIA
PLUMBING
 SECTIONS - SHEET 1 OF 2

PLAN _____
 FILE _____
 P-301
 SHEET 49 OF 51

SHEET NOTES:

- SEE SHEET P001 FOR PLUMBING GENERAL NOTES, ABBREVIATIONS AND LEGEND.
- REFER TO STRUCTURAL DRAWINGS FOR DOCK STRUCTURES.
- PROVIDE 316 SS HANGERS, PIPE CLAMPS AND BRACING FOR PIPING IN ACCORDANCE WITH CPC AND CBC. ANCHORS AND BOLTING SHALL BE 316 SS.

KEY NOTES:

- 2"Ø POTABLE CW PIPELINE ALONG UNDERSIDE OF WALKWAY WALER. ANCHOR PIPE TO BOTTOM OF WALER.

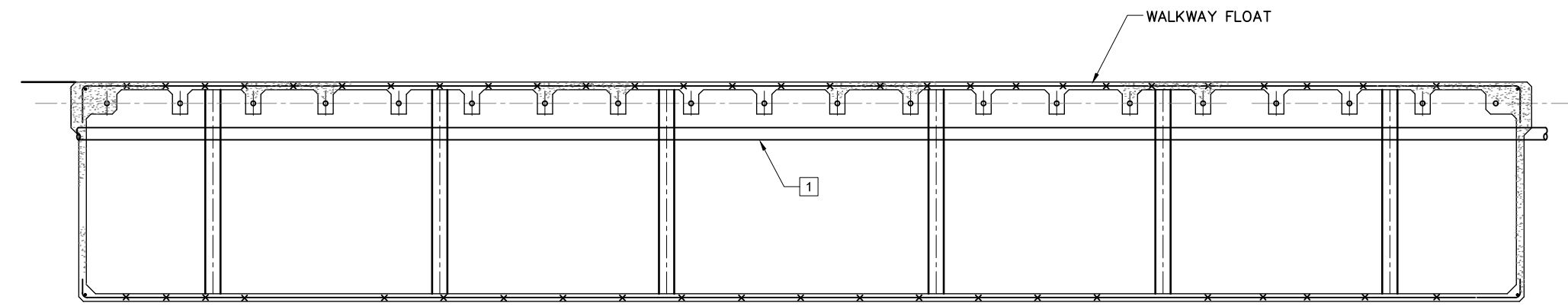

WALKWAY SECTION

SCALE: 1" = 1'-0"

A
P-401

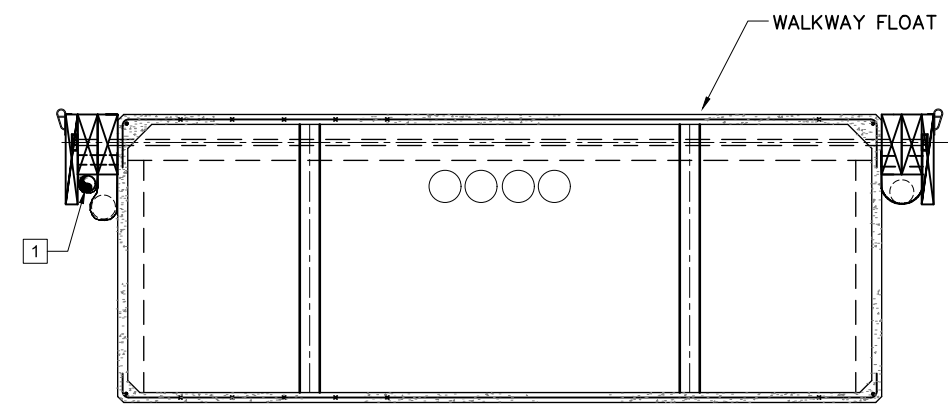

WALKWAY SECTION

SCALE: 1" = 1'-0"

B
P-401

DRAFT 90% Submittal

REVISION	MARK	DATE	DESCRIPTION	APPROVAL
B		03-27-2023	60% PROGRESS SUBMITTAL	PM
A		08-03-2022	30% PROGRESS SUBMITTAL	PM



PROJECT MANAGER: _____ DATE _____
 SURVEY PARTY CHIEF _____
 WATERSHED REVIEW: _____ DATE _____

DEPICTION OF MONUMENTS: _____ DATE _____
 SURVEY PARTY CHIEF _____
 WATERSHED REVIEW: _____ DATE _____

SUBMITTED: _____ DATE _____
 SUPERVISING CIVIL ENGINEER _____
 APPROVED: _____ DATE _____
 CITY ENGINEER _____

DESIGN: _____ B.H. _____
 DRAWN: _____ P.W. _____
 CHECK: _____ P.M. _____
 AS BUILT _____ DATE _____



BERKELEY MARINA DOCK REPLACEMENT (D-E)
 CITY OF BERKELEY, ALAMEDA COUNTY, CALIFORNIA
PLUMBING
 SECTIONS - SHEET 2 OF 2

PLAN _____
 FILE _____
 P-302
 SHEET 50 OF 51

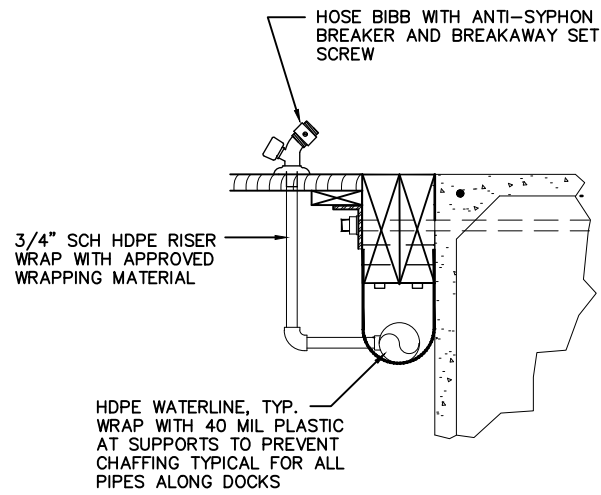

HOSE BIB DETAIL

SCALE: NTS

1
P-401

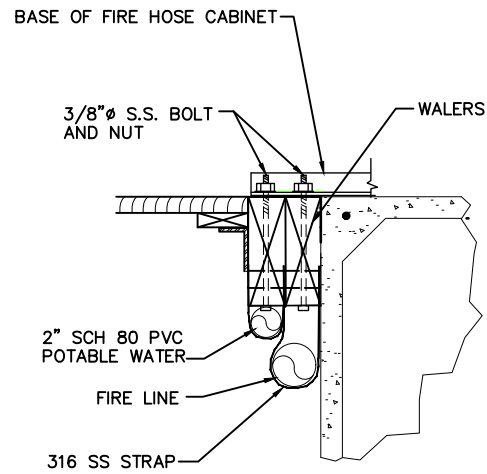

WALKWAY PIPE SUPPORT DETAIL

SCALE: NTS

2
P-401

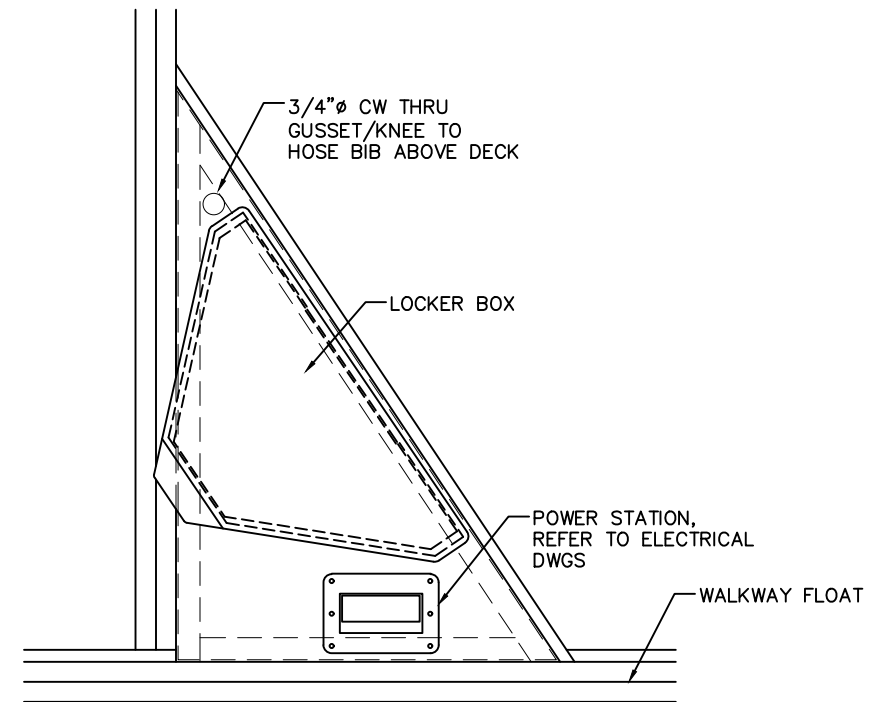

HOSE BIB DETAIL

SCALE: NTS

3
P-401

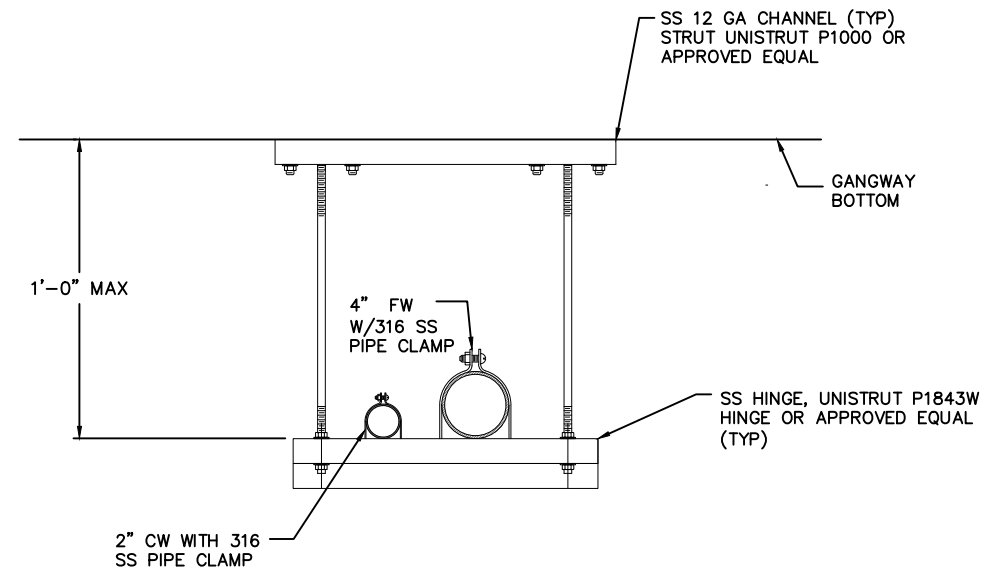

GANGWAY PIPE SUPPORT DETAIL

SCALE: NTS

4
P-401

DRAFT 90% Submittal

NO.	DATE	DESCRIPTION	MARK	APPROVAL
1	05-12-2023	80% PROGRESS SUBMITTAL		



PROJECT MANAGER: _____ DATE _____
 SURVEY PARTY CHIEF _____
 WATERSHED REVIEW: _____ DATE _____
 FOR REDUCED PLANS - ORIGINAL SCALE IS IN INCHES

DEPICTION OF MONUMENTS: _____ DATE _____
 SURVEY PARTY CHIEF _____
 WATERSHED REVIEW: _____ DATE _____

SUBMITTED: _____ DATE _____
 SUPERVISING CIVIL ENGINEER _____
 APPROVED: _____ DATE _____
 CITY ENGINEER _____

DESIGN: _____ B.H. _____
 DRAWN: _____ P.W. _____
 CHECK: _____ P.M. _____
 AS BUILT _____ DATE: 05/12/23



BERKELEY MARINA DOCK REPLACEMENT (D-E)
 CITY OF BERKELEY, ALAMEDA COUNTY, CALIFORNIA
**PLUMBING
 DETAILS**

PLAN _____
 FILE _____
 P-401
 SHEET 51 OF 51