



Civic Arts Commission

## **Civic Arts Commission Meeting**

**Wednesday, March 15, 2023**

**6:00 PM**

**Meeting Location: Tarea Hall Pittman South Branch Library  
1901 Russell St., Berkeley, CA 94703**

### **Agenda**

**1. CALL TO ORDER**

**2. ROLL CALL**

**3. LAND ACKNOWLEDGEMENT**

The City of Berkeley recognizes that the community we live in was built on the territory of xučyun (Huchiun (Hooch-yoon)), the ancestral and unceded land of the Chochenyo (Chochen-yo)-speaking Ohlone (Oh-low-nee) people, the ancestors and descendants of the sovereign Verona Band of Alameda County. This land was and continues to be of great importance to all of the Ohlone Tribes and descendants of the Verona Band. As we begin our meeting tonight, we acknowledge and honor the original inhabitants of Berkeley, the documented 5,000-year history of a vibrant community at the West Berkeley Shellmound, and the Ohlone people who continue to reside in the East Bay. We recognize that Berkeley's residents have and continue to benefit from the use and occupation of this unceded stolen land since the City of Berkeley's incorporation in 1878. As stewards of the laws regulating the City of Berkeley, it is not only vital that we recognize the history of this land, but also recognize that the Ohlone people are present members of Berkeley and other East Bay communities today. The City of Berkeley will continue to build relationships with the Lisjan Tribe and to create meaningful actions that uphold the intention of this land acknowledgement.

**4. PUBLIC COMMENT** (for items not on the agenda)

## 5. APPROVAL OF MINUTES

- a) Draft Minutes of February 22, 2023 Meeting (Attachment 1)  
From: Commission Secretary  
Recommendation: Approval of February 22, 2023 Meeting Minutes

## 6. CHAIR'S REPORT

- a) Welcome back to in-person meetings
- b) Appreciation to outgoing chair and vice chair
- c) Subcommittee members

## 7. PRESENTATIONS, DISCUSSION & ACTION ITEMS (All items for presentation, discussion and possible action)

- a) Action Item: Approval of Design Development by Lara Kaur for West Service Center (Attachment 2)  
From: Zoë Taleporos  
Recommendation: Approve Design Development by Lara Kaur for West Service Center.
  
- b) Action Item: Approval of Revised Design for Mural at James Kenney Community Center (Attachment 3)  
From: Jennifer Lovvorn  
Recommendation: Approve revised design by Rachel Wolfe-Goldsmith for the mural at James Kenney Community Center.
  
- c) Discussion Item: Draft Poet Laureate Program Guidelines (Attachment 4)  
From: Hilary Amnah

## 8. STAFF REPORT

- a) Civic Arts Updates, Jennifer Lovvorn
  
- b) Public Art Program Updates, Zoë Taleporos
  
- c) Grants Program Updates, Hilary Amnah

## 9. COMMITTEE REPORTS

- a) Grants
  - Dana Blecher, Chair
  - Liz Ozol
  - Cameron Woo

- b) Policy
  - Kim Anno, Chair
  - Lisa Bullwinkel
  - Modesto Covarrubias
  - Cameron Woo
- c) Public Art
  - Matt Passmore, Chair
  - Kim Anno
  - Dana Blecher
  - Riti Dhesi
- d) Representatives on Civic Center Project
  - Lisa Bullwinkel
  - Liz Ozol
  - Cameron Woo
- e) Representative on Berkeley Cultural Trust
  - Lisa Bullwinkel
- f) Representatives on Berkeley Arts Education Steering Committee
  - Liz Ozol
- g) Representative on Design Review Committee
  - Cameron Woo
- h) Representative on Ad-Hoc Artists Affordable Housing Committee
  - Kim Anno

**10. COMMUNICATION** (Received from the Public for Items not on the Agenda)

- a) Letter from Community for a Cultural Civic Center (Attachment 5)

**11. ADJOURNMENT**

**Attachments:**

1. February 22, 2023 Draft Minutes
2. Design Development by Lara Kaur for West Service Center
3. Revised Mural Design by Rachel Wolfe-Goldsmith for James Kenney Community Center
4. Draft Poet Laureate Program Guidelines
5. Letter from Community for a Cultural Civic Center

Staff Contact:  
Jennifer Lovvorn  
Secretary to the Civic Arts Commission  
Berkeley, CA 94704  
Telephone (510) 981-7533  
TDD (510) 981-6903  
jlovvorn@cityofberkeley.info

Communications to Berkeley boards, commissions or committees are public record and will become part of the City's electronic records, which are accessible through the City's website. Please note: e-mail addresses, names, addresses, and other contact information are not required, but if included in any communication to a City board, commission or committee, will become part of the public record. If you do not want your e-mail address or any other contact information to be made public, you may deliver communications via U.S. Postal Service or in person to the secretary of the relevant board, commission or committee. If you do not want your contact information included in the public record, please do not include that information in your communication. Please contact the secretary to the relevant board, commission or committee for further information.

**ACCESSIBILITY INFORMATION:**

**This meeting is being held in a wheelchair accessible location. To request a disability-related accommodation(s) to participate in the meeting, including auxiliary aids or services, please contact the Disability Services specialist at 981-6418 (V) or 981-6347 (TDD) at least three business days before the meeting date. Please refrain from wearing scented products to this meeting.**



Civic Arts Commission

**Draft Minutes**  
**Civic Arts Commission Meeting**  
**Wednesday, February 22, 2023**  
**6:00 PM**

**No physical location; meeting held exclusively through videoconference and teleconference.**

**1. CALL TO ORDER 6:01 PM**

**2. ROLL CALL**

**Commissioners Present:** Anno, Blecher, Bullwinkel, Covarrubias, Dhesi, Ibarra, Ozol, Passmore, Woo.

**Commissioners Absent:** None.

**Staff Present:** Hilary Amnah, Grants Program Lead; Jennifer Lovvorn, Commission Secretary/Chief Cultural Affairs Officer; Zoë Taleporos, Public Art Program Lead.

**Members of the public in attendance:** 2

**3. LAND ACKNOWLEDGEMENT**

**4. PUBLIC COMMENT (for items not on the agenda)**

1

**5. APPROVAL OF MINUTES**

- a) Draft Minutes of January 18, 2023 Meeting  
From: Commission Secretary  
Action: M/S/C (Woo/Anno) to approve the January 18, 2023 Draft Minutes.  
Vote: Ayes — Anno, Blecher, Bullwinkel, Covarrubias, Dhesi, Ibarra, Ozol, Passmore, Woo; Nays — None; Abstain — None; Absent — None.

## 6. CHAIR'S REPORT

- a) Commission resuming in-person (not hybrid) meetings at the Tarea Hall Pittman South Branch Library starting in March, and subcommittees still meeting online for now.

## 7. PRESENTATIONS, DISCUSSION, AND ACTION ITEMS

- a) Introduction of Civic Arts Intern Andrea Calderon  
From: Jennifer Lovvorn
- b) Action Item: Approval of Revised Design for Mural at James Kenney Community Center  
From: Jennifer Lovvorn  
No action taken.
- c) Action Item: Election of Chair and Vice Chair  
From: Chair  
Action: M/S/C (Covarrubias/Passmore) to approve newly elected Chair and Vice Chair; Dana Blecher as Chair and Riti Dhesi as Vice Chair.  
Vote: Ayes — Anno, Blecher, Bullwinkel, Covarrubias, Dhesi, Ibarra, Ozol, Passmore, Woo; Nays — None; Abstain — None; Absent — None.

## 8. STAFF REPORTS

- a) Civic Arts Updates, Jennifer Lovvorn
- b) Public Art Program Updates, Zoë Taleporos
- c) Grants Program Updates, Hilary Amnah

## 9. COMMITTEE REPORTS

- a) Grants
  - Dana Blecher, Chair
  - Liz Ozol
  - Cameron Woo
- b) Policy
  - Kim Anno, Chair
  - Lisa Bullwinkel
  - Modesto Covarrubias
  - Cameron Woo

- c) Public Art
  - Matt Passmore, Chair
  - Kim Anno
  - Dana Blecher
  - Riti Dhesi
  
- d) Representatives on Civic Center Project
  - Lisa Bullwinkel
  - Liz Ozol
  - Cameron Woo
  
- e) Representative on Berkeley Cultural Trust
  - Lisa Bullwinkel
  
- f) Representatives on Berkeley Arts Education Steering Committee
  - Liz Ozol
  
- g) Representative on Design Review Committee
  - Cameron Woo
  
- h) Representative on Ad-Hoc Artists Affordable Housing Committee
  - Kim Anno

**10. COMMUNICATION** (Received from the Public for Items not on the Agenda)

- a) Email from Deb Durant
- b) Health and Safety Protocols for Commissions

**11. ADJOURNMENT 7:58 PM**

Action: M/S/C (Woo/Ibarra) to adjourn the meeting.

Vote: Ayes — Anno, Blecher, Bullwinkel, Covarrubias, Dhesi, Ibarra, Ozol, Passmore, Woo;

Nays — None; Abstain — None; Absent — None.

Staff Contact:

Jennifer Lovvorn



Secretary to the Civic Arts Commission

Berkeley, CA 94704

Telephone (510) 981-7533

TDD (510) 981-6903

[jlovvorn@cityofberkeley.info](mailto:jlovvorn@cityofberkeley.info)

Communications to Berkeley boards, commissions or committees are public record and will become part of the City's electronic records, which are accessible through the City's website. Please note: e-mail addresses, names, addresses, and other contact information are not required, but if included in any communication to a City board, commission or committee, will become part of the public record. If you do not want your e-mail address or any other contact information to be made public, you may deliver communications via U.S. Postal Service or in person to the secretary of the relevant board, commission or committee. If you do not want your contact information included in the public record, please do not include that information in your communication. Please contact the secretary to the relevant board, commission or committee for further information.

**ACCESSIBILITY INFORMATION:**

**To request a disability-related accommodation(s) to participate in the meeting, including auxiliary aids or services, please contact the Disability Services specialist at 981-6418 (V) or 981-6347 (TDD) at least three business days before the meeting date.**



# WEST BERKELEY SERVICE CENTER

1900 Sixth St  
Berkeley, CA 94710  
Schematic Design - 03.09.2022

City of Berkeley

**NOLL  
& TAM**  
ARCHITECTS

729 Heinz Avenue  
Berkeley, CA 94710  
tel 510.542.2200  
fax 510.542.2201

SEAL  
**DRAFT!  
NOT FOR  
CONSTRUCTION**

APPROVALS

PROJECT TITLE

**City of Berkeley  
WEST  
BERKELEY  
SERVICE  
CENTER**

1900 Sixth St  
Berkeley, CA 94710

**Schematic Design**

**PRICING SET**

ISSUE DATE 03.09.2022

N&T JOB NUMBER 22121

REVISIONS

DATE	DESCRIPTION

DRAWN BY Author CHECKED BY Checker

SHEET TITLE

**COVER SHEET**

SHEET NUMBER

**GO.00**

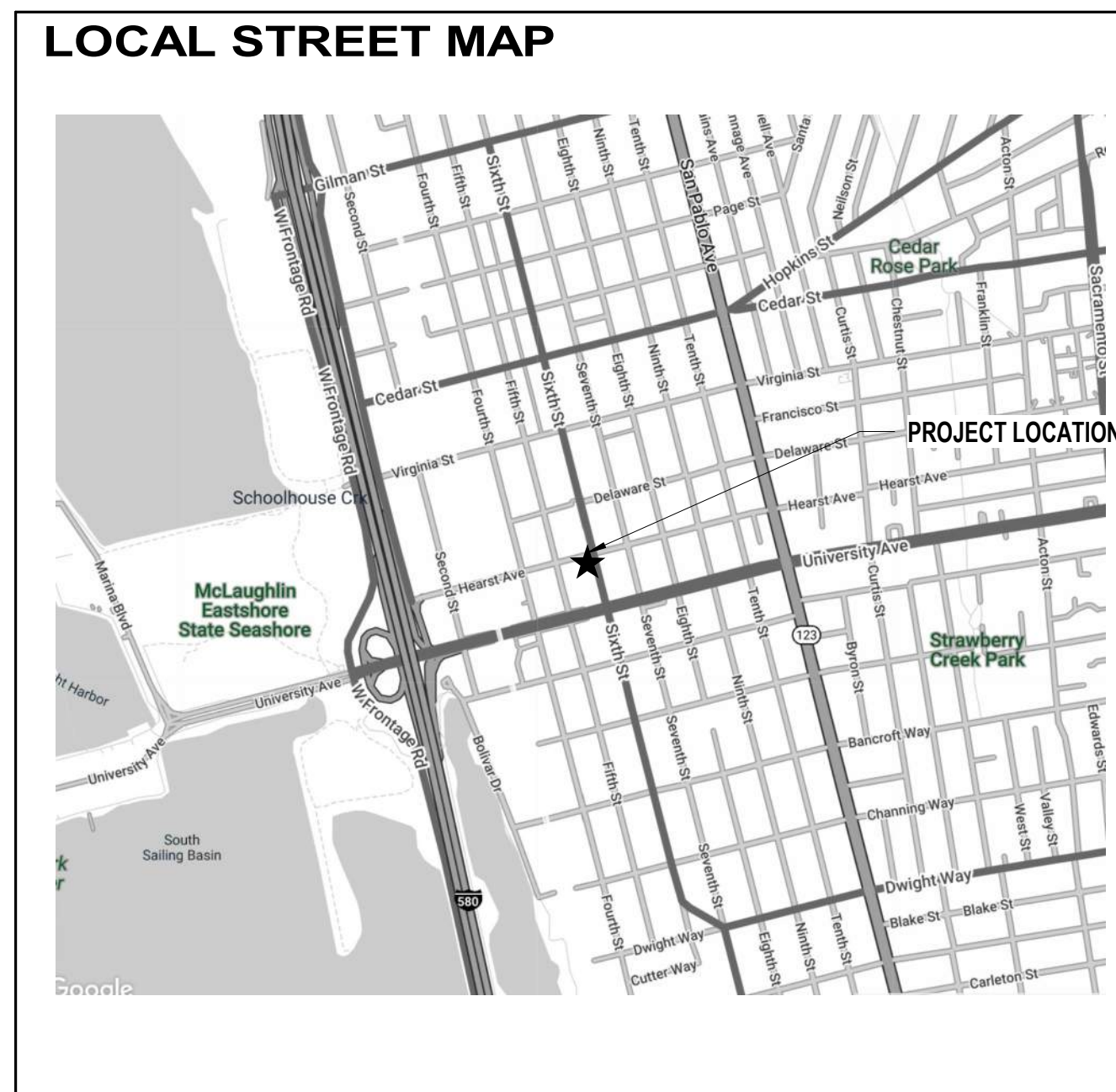
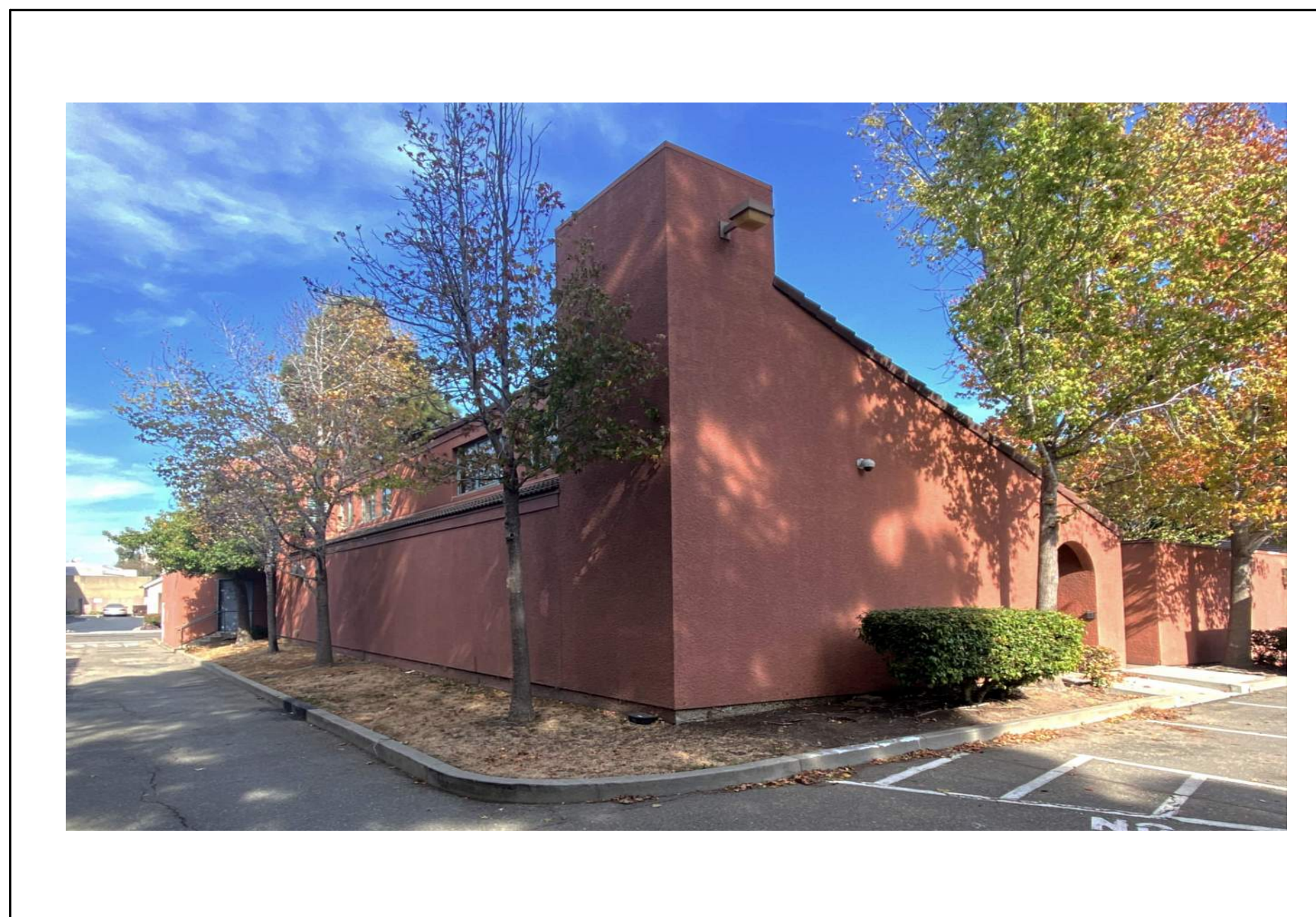

**PROJECT SUMMARY**

THE PROJECT IS A RENOVATION OF AN EXISTING, 9,836 S.F., ONE-STORY, TYPE-V, NON-RATED, WOOD FRAMED BUILDING.

THE PROJECT SCOPE INCLUDES, BUT IS NOT LIMITED TO, NEW ROOFING, UPGRADED ELECTRICAL SYSTEM, UPGRADED MECHANICAL SYSTEMS, MINOR INTERIOR MODIFICATIONS REQUIRED FOR NEW MECHANICAL SYSTEM, REMOVAL OF EXISTING FIRE PLACE, AND LANDSCAPING IMPROVEMENTS.

CONTRACTOR WILL BE RESPONSIBLE FOR PREPPING ALL AREAS FOR NEW SCOPE OF WORK INCLUDING PATCHING AND REPAIRING EXISTING CONDITIONS WHERE AFFECTED BY ANY AND ALL DEMOLITION WORK.

THE WORK TO BE PERFORMED UNDER THIS CONTRACT INCLUDES THE FURNISHING OF ALL LABOR, MATERIALS, EQUIPMENT, TRANSPORTATION, SERVICES, PERMITS, TEMPORARY CONTROLS AND CONSTRUCTION FACILITIES, AND ALL GENERAL CONDITIONS, SEISMIC REQUIREMENTS, GENERAL REQUIREMENTS AND INCIDENTALS REQUIRED TO COMPLETE THE WORK ON THE PROJECT IN ITS ENTIRETY AS DESCRIBED IN THE CONTRACT DOCUMENTS.

**Cost Estimator**

**Leland Saylor Associates**  
1629 Telegraph Ave  
Oakland CA 94612  
Tel: (510) 986-1212

**Electrical**

**RIJA**  
5515 Doyle Street, #7  
Emeryville CA 94608  
Tel: (415) 730-7994

**MEP**

**EPE Inc**  
274 Devonshire Street  
Vallejo CA 94591  
Tel: (707) 980-4049

**Structural  
IDA Structural Engineers  
Inc.**

1629 Telegraph Avenue  
Suite 300  
Oakland CA 94612-2114  
Tel: (510) 834-1629

**Landscape  
John Northmore Roberts  
and Associates**

2927 Newberry Street, Ste B  
Berkeley CA 94703  
Tel: (510) 843-3666

**Civil**

**BKF Engineers**  
254 Shoreline Drive Suite  
200  
Redwood City CA 94065  
Tel: (650) 482-6300

**Architect**

**Noll & Tam Architects**  
729 Heinz Ave  
Berkeley, CA 94710  
Tel: 510.542.2200  
Fax: 510.542.2201

**Client**

**City of Berkeley**  
Public Works Department  
1947 Center Street, 5th floor  
Tel: (510) 981-6435

SEAL  
**DRAFT!  
NOT FOR  
CONSTRUCTION**

APPROVALS

PROJECT TITLE

**City of Berkeley  
WEST  
BERKELEY  
SERVICE  
CENTER**

1900 Sixth St  
Berkeley, CA 94710

**Schematic Design**  
PRICING SET

ISSUE DATE	03.09.2022
N&T JOB NUMBER	22121
REVISIONS	
DATE	DESCRIPTION

DRAWN BY **Author** CHECKED BY **Checker**  
SHEET TITLE  
**REFLECTED CEILING  
PLAN**

SHEET NUMBER

**A2.41**

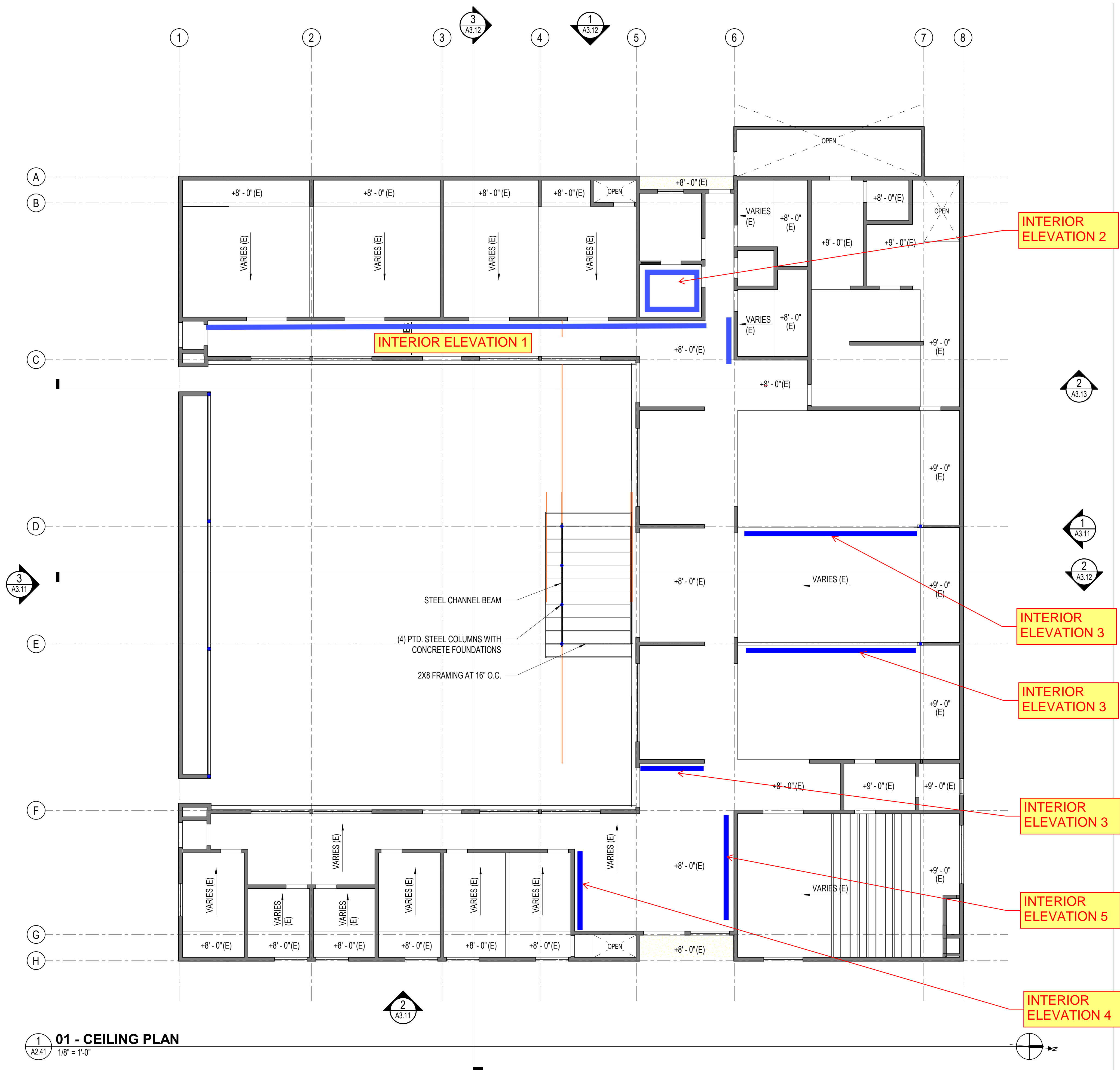

**01 - CEILING PLAN**  
1/A2.41 1/8" = 1'-0"

3/7/2022 6:10:27 PM Autodesk Docs://Berkeley West Senior Center/Berkeley West Senior Center.rvt

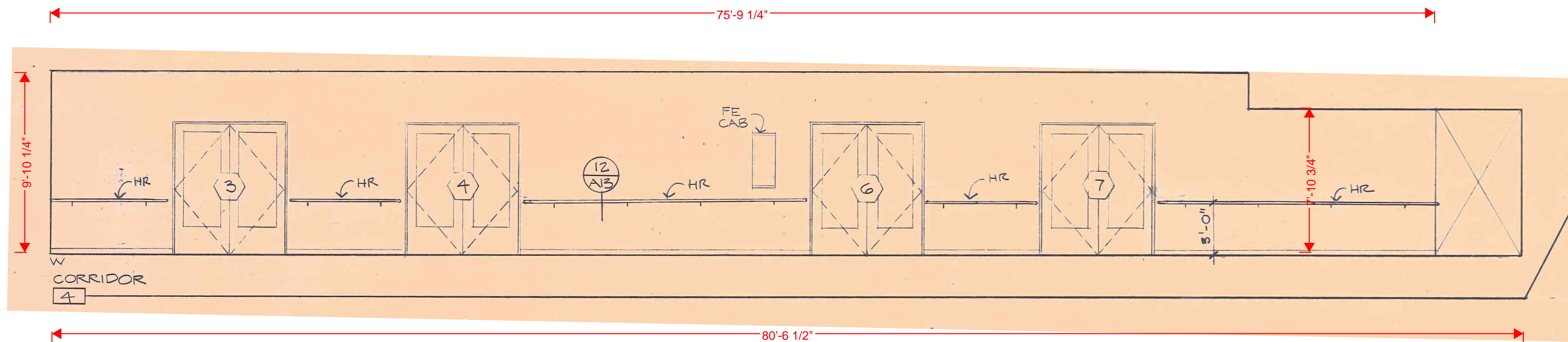

INTERIOR ELEVATION 1

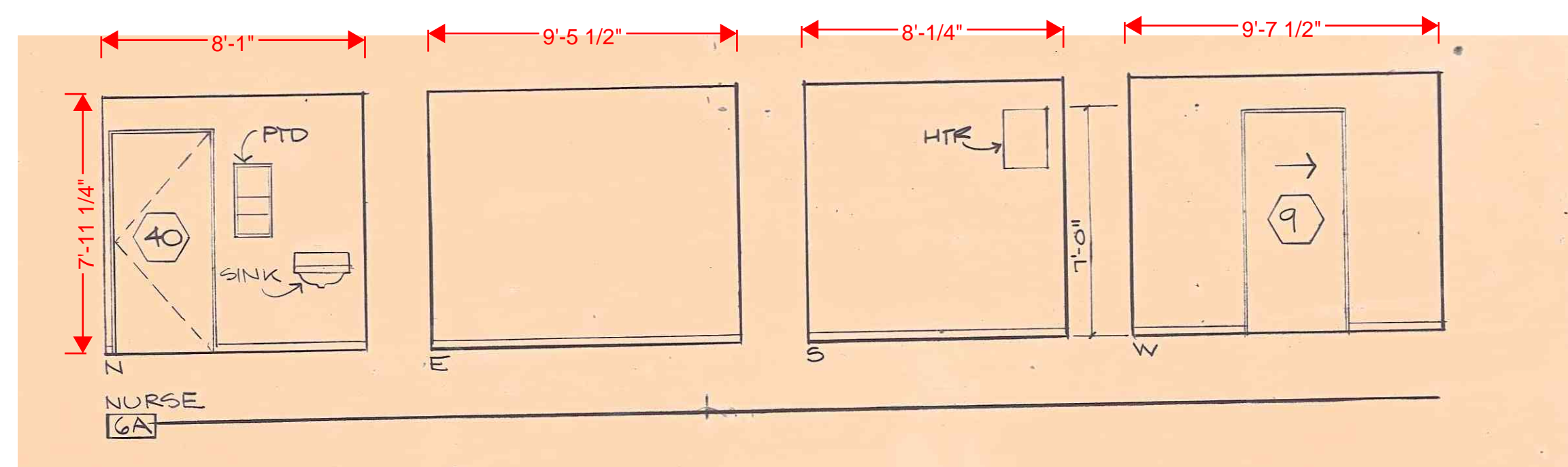

INTERIOR ELEVATION 2

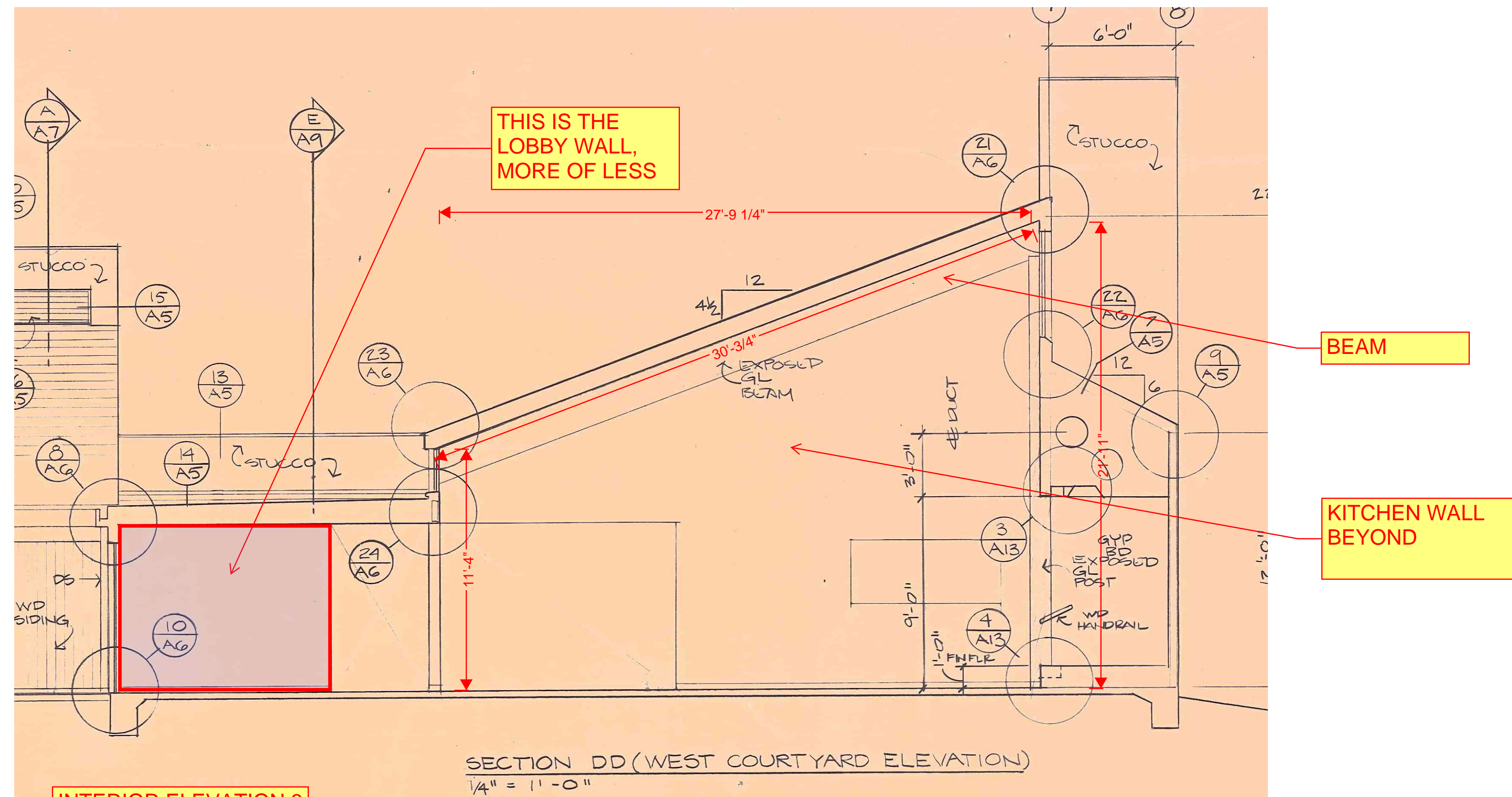

INTERIOR ELEVATION 3

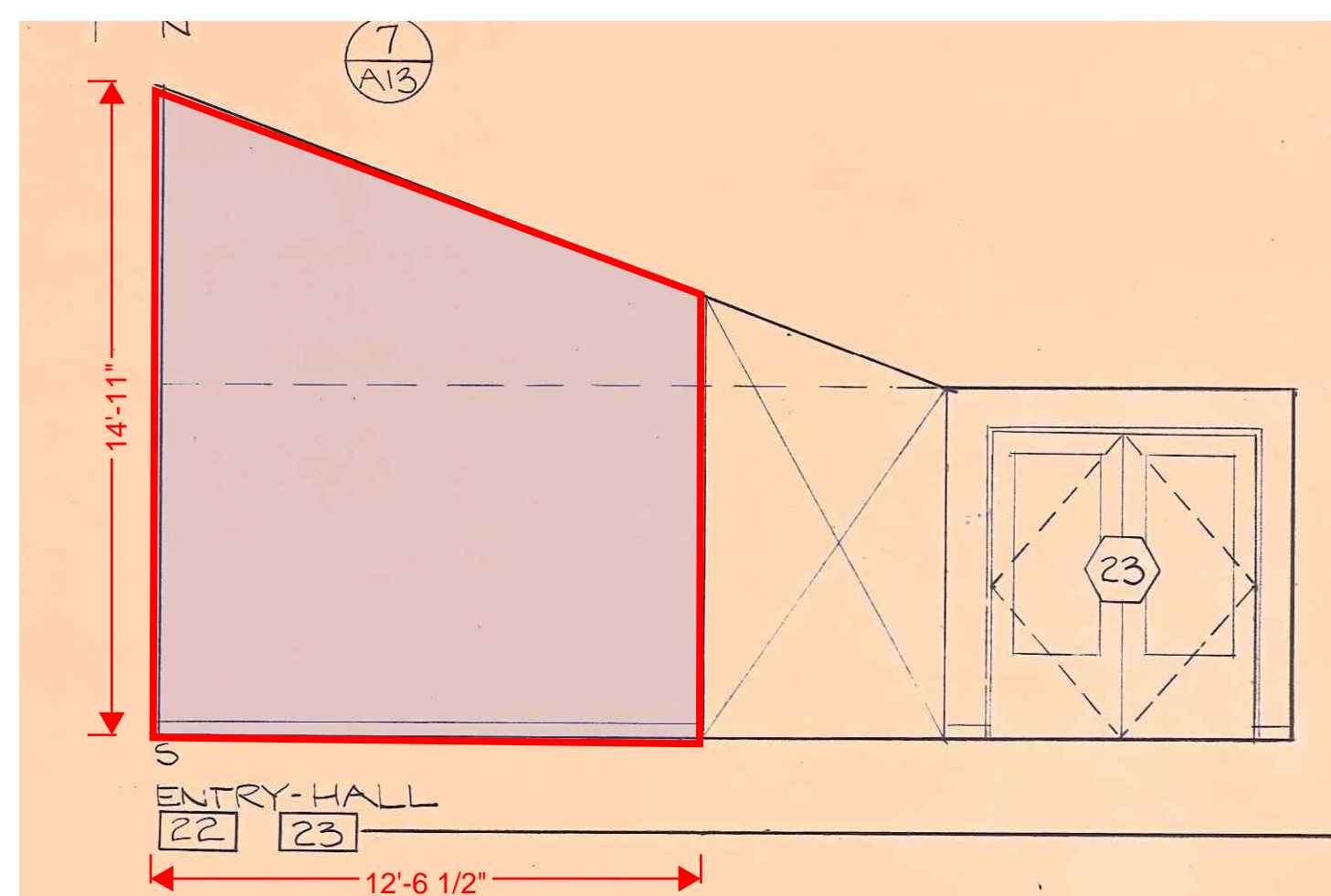

INTERIOR ELEVATION 4

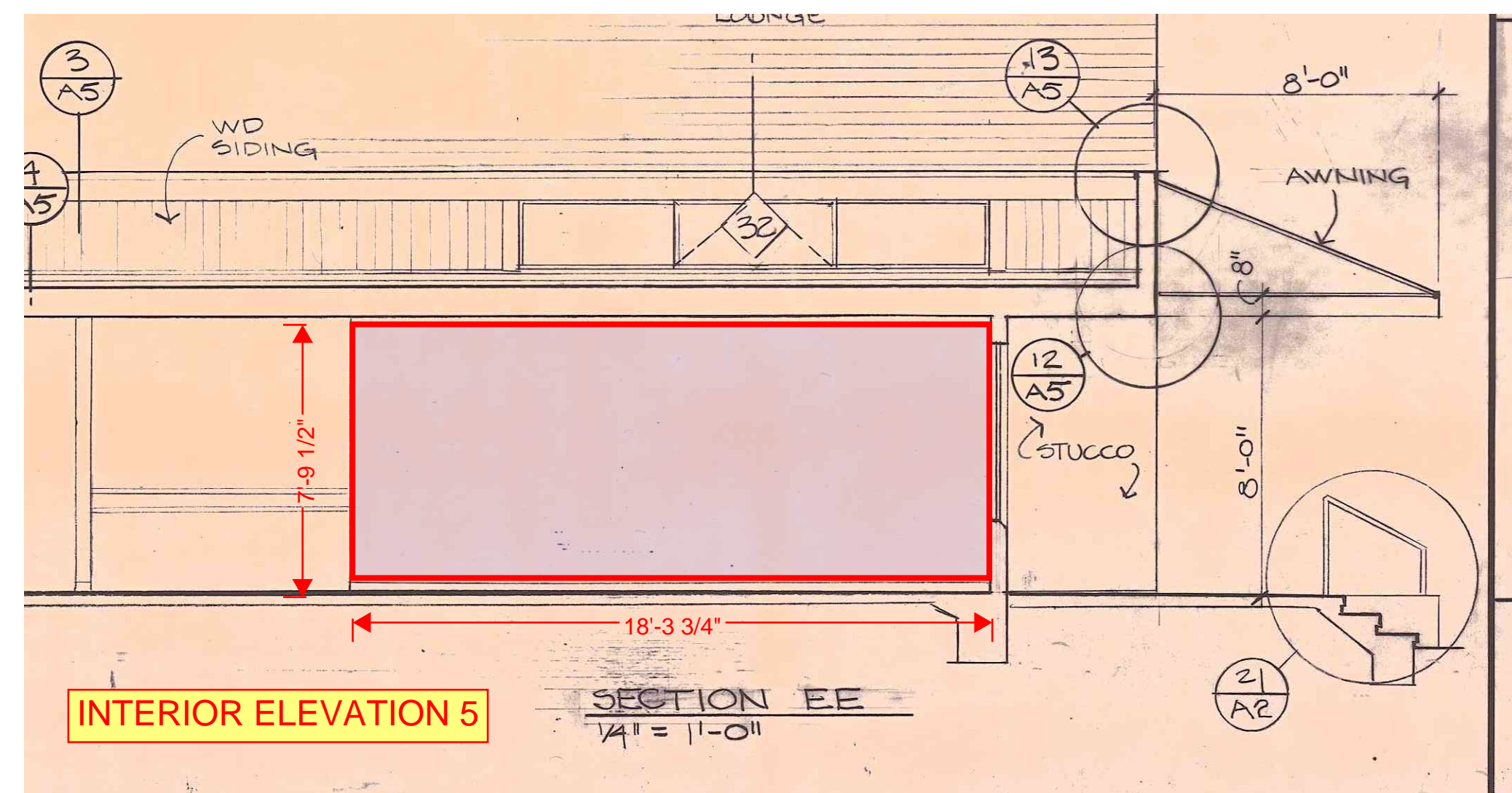

INTERIOR ELEVATION 5









Please do not  
use - will use for  
rest of picking  
Thanks 😊 MAF





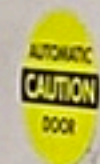





— 01

# The West Berkeley Service Center

PREPARED FOR: THE  
BERKELEY CIVIC ART  
COMMISSION

BY LARA KAUR



My name is Lara Kaur and I am a photographer, social worker, and educator based in Oakland, CA. I am dedicated to centering community and sharing the stories of individuals that are often underrepresented or misrepresented in mainstream media. My photography focuses on community narratives and holds space for people to be seen and recognized as they see themselves, particularly women and femme identifying folks. I believe photography offers us a universal form of connection, healing, resistance, and historical memory.

# About Lara Kaur

SOCIAL WORKER

PHOTOGRAPHER

COMMUNITY ADVOCATE



# The Year Ahead

## **JAN-FEB 23 FINALIZE BUILDING LAYOUT**

Adjust any building layout propositions as needed

## **APR-JULY 23 COMMUNITY PHOTOSHOOTS & EDITING**

Create and document five additional photoshoots with Berkeley community members

## **JULY-SEPT 23 PRINTING & FRAMING**

Prepare final images from additional photoshoots for printing + prepare all images for framing

## **OCT-DEC 23 INSTALLATION**

Install all framed images & fabric pieces at the West Berkeley Service Center

**03**

## **PRINT PUBLIC ARTIST RESIDENCY**

Initial stage of project was completed through the Kala Art Institute's public art residency in partnership with the City of Berkeley's Department of Health, Housing, and Community Services will focus on areas related to community well-being and resilience and recovery during the pandemic (January 2021-January 2022).

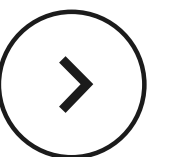

# Community Wellness Is...

An audio & visual project documenting what community wellness looks like, driven by and for the community. Including narratives & reflections from across the Berkeley community.

04



The project includes reflections from folks from across generations, races, abilities, gender and sexual identities, cultures, neighborhoods, and practices. Including: activists, advocates for houseless communities & Housing Counselors, Berkeley Black Infant Health, the Cheeseboard Collective, community healers & leaders, the Confederated Villages of Lisjan/Ohlone, the Ecology Center, Franklin Bros. Market, Healthy Black Families, Lifelong Medical, Malcolm X Elementary School, Mental Health Specialists, Multicultural Institute, Waterfront, West Berkeley, and Wee Poets.









Community members were asked to identify spaces, meaningful items, locations, and/or activities/practices that represented their wellness. In addition to each photoshoot, participants were asked to share reflections on the following questions:

- What does wellness look like for you?
- What are your personal or cultural wellness practices?
- Do you have a space that represents your wellness?
- How do you define wellness?
- What message(s) do you hope to pass to future generations about wellness?
- Complete this sentence..."Wellness is\_\_\_\_\_"



# The power of storytelling + photographs:

## FUTURE WORK WILL INCLUDE:

- **NURSING/PREGNANT INDIVIDUALS**
- **INDIGENOUS COMMUNITY MEMBERS**
- **FAMILIES**





**Learn  
more @  
larakaur.  
com**



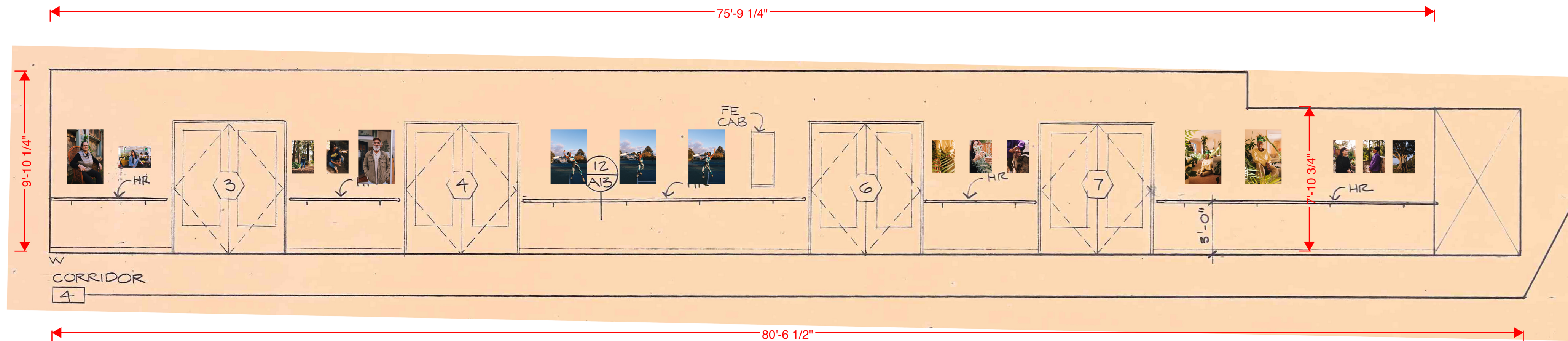

INTERIOR ELEVATION 1

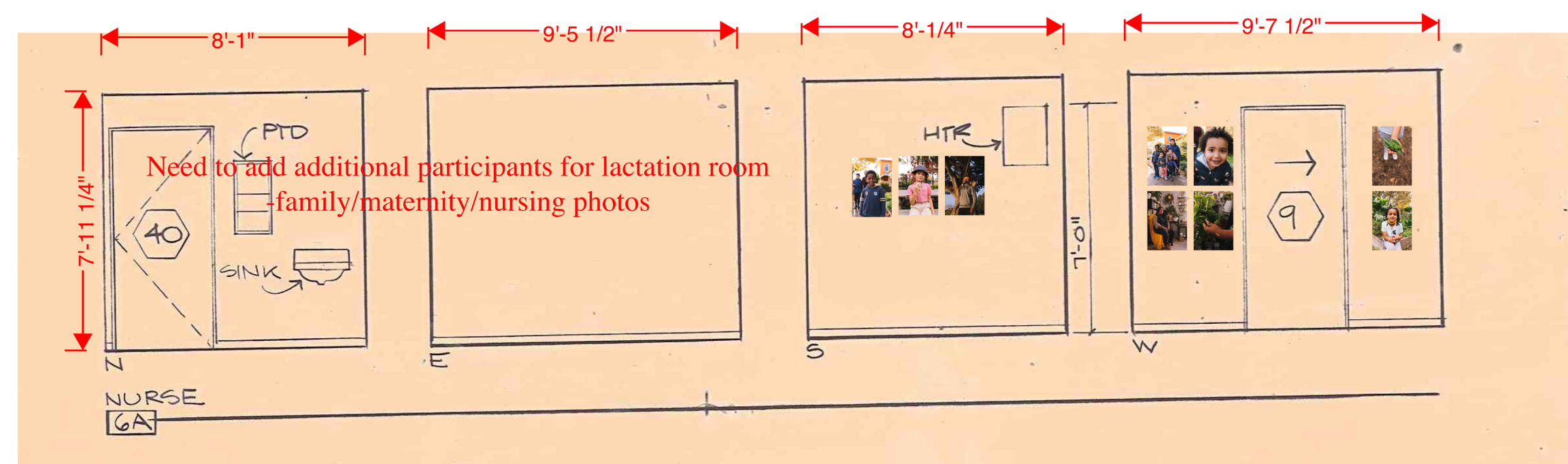

INTERIOR ELEVATION 2

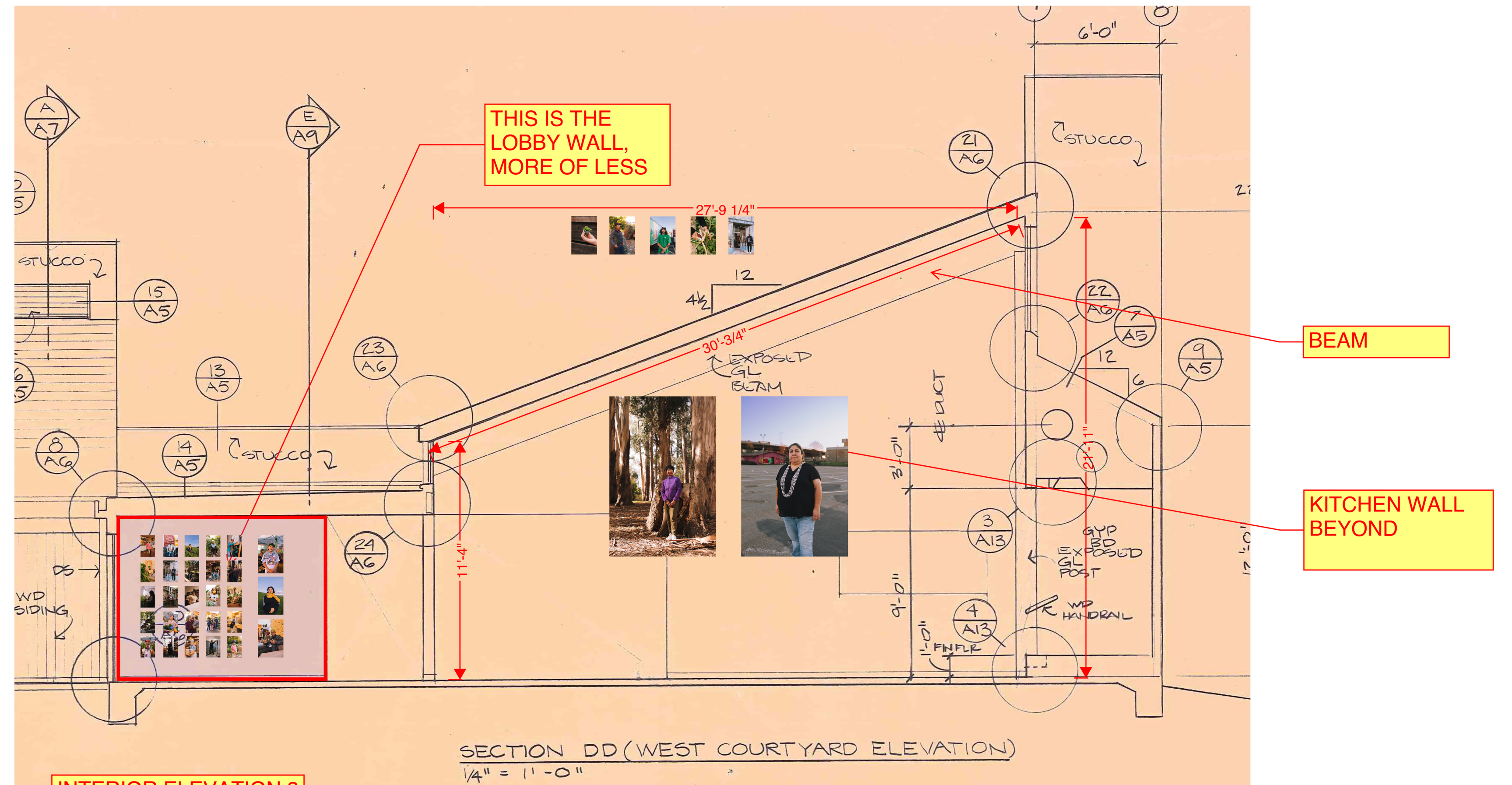

INTERIOR ELEVATION 3

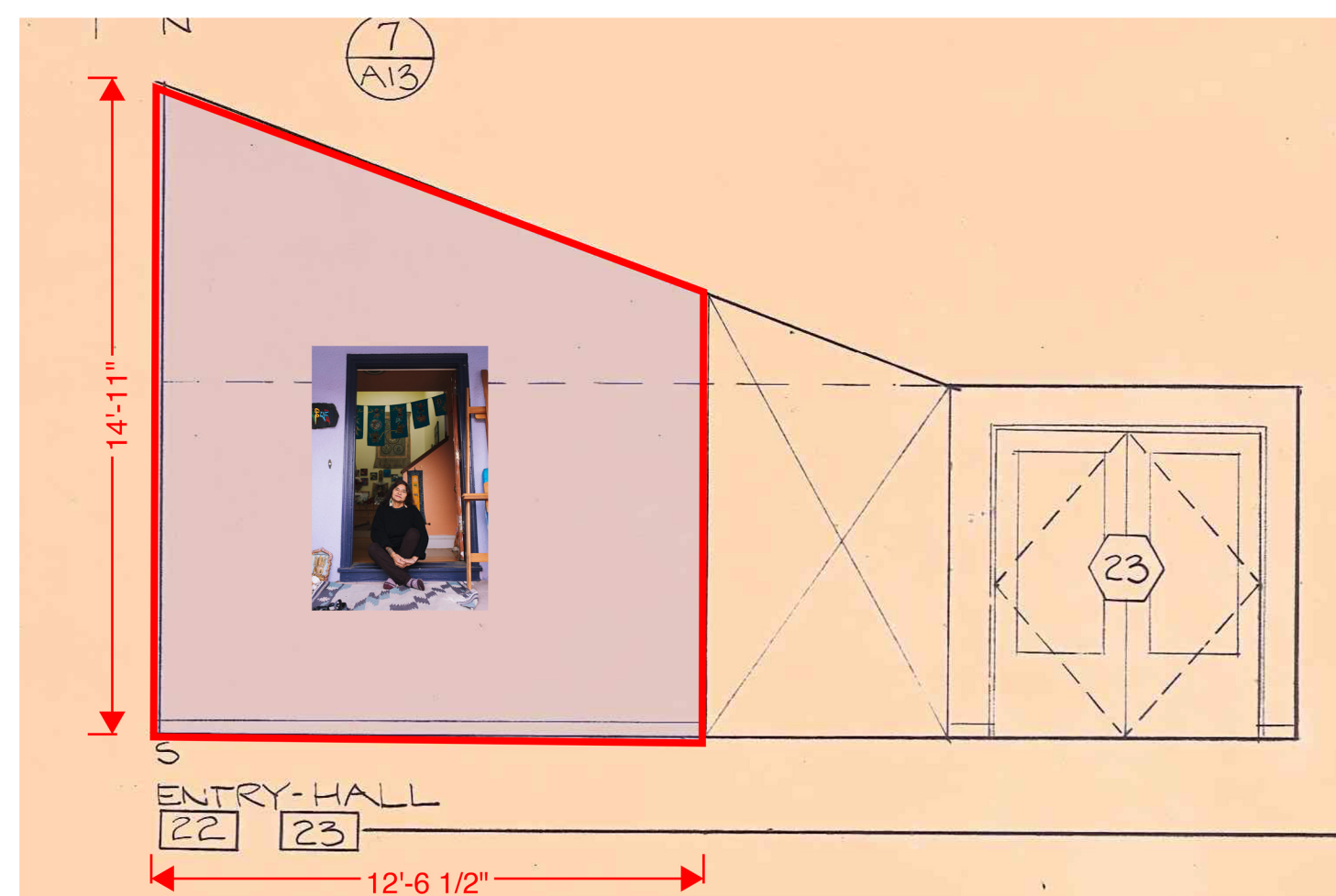

INTERIOR ELEVATION 4

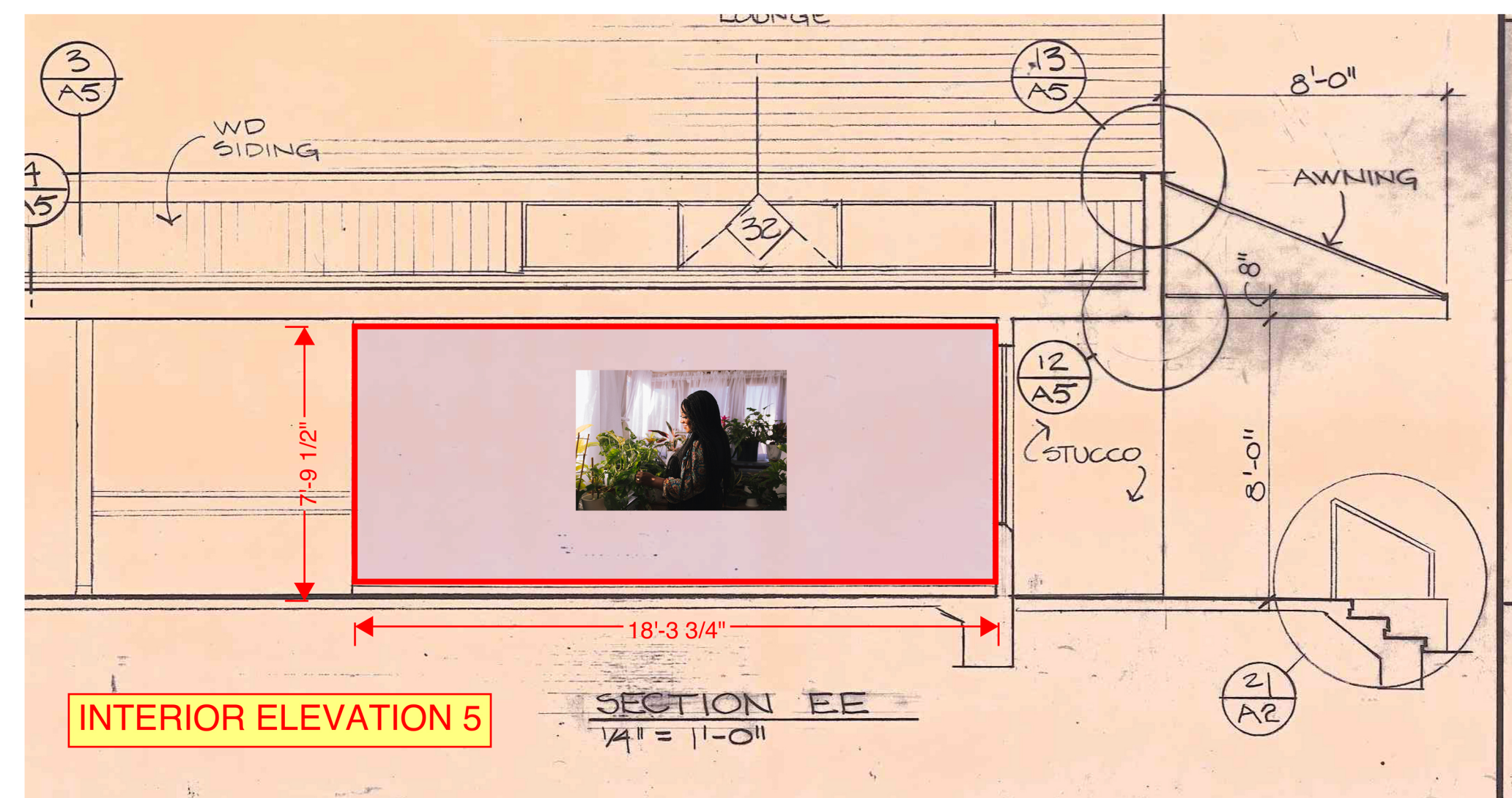

INTERIOR ELEVATION 5

**April 2022 City of Berkeley - West Service Center Proposed Budget**

<b>Description</b>	<b>Unit Cost</b>	<b>Unit Amount</b>	<b>Total (Do Not Edit)</b>	<b>REFORECAST NOTES</b>
<b>Additional Prints</b>				
12x18 portrait prints	\$17	7	\$116	
20x30 portrait prints	\$53	3	\$159	
40x60 fabric prints - Elements Fire Opal Bright White Canvas (425 gsm)	\$185	6	\$1,110	
<b>Framing (all #s include 25% discount)</b>				
8x12 with mat, optium, wood frame	\$345	27	\$6,985	
12x18 with mat, optium, wood frame	\$447	33	\$11,047	
20x30 with mat, optium, wood frame	\$660	10	\$4,945	
40x60 with mat, optium, wood frame	\$1,966	2	\$2,948	
<b>Installation</b>				
Scope: - installation of 72 framed works with security hardware - installation of 6, 40x60 fabric prints (ceiling or wall install tbd)  Estimate: Crew of 3 @ \$230/hr X 4 days (9hrs/day) : \$8280 Materials (security hardware sets and supplies for fabric print install): \$200 Total: \$8480	\$8,480	1	\$8,480	
<b>Storage</b>				
Monthly storage fee to store current prints at Kala	85	12	\$1,020	
<b>Additional Labor</b>				

Additional photographer's fee for photoshoots	\$450	5	\$2,250	
		<b>10% Contingency</b>	<b>\$4,312</b>	
		<b>Artist Fee</b>	<b>\$12,000</b>	
		<b>Total Proposed Budget</b>	<b>\$43,372</b>	



# Rachel Wolfe-Goldsmith Mural for James Kenney Park

Presentation to Civic Arts Commission

March 15, 2023

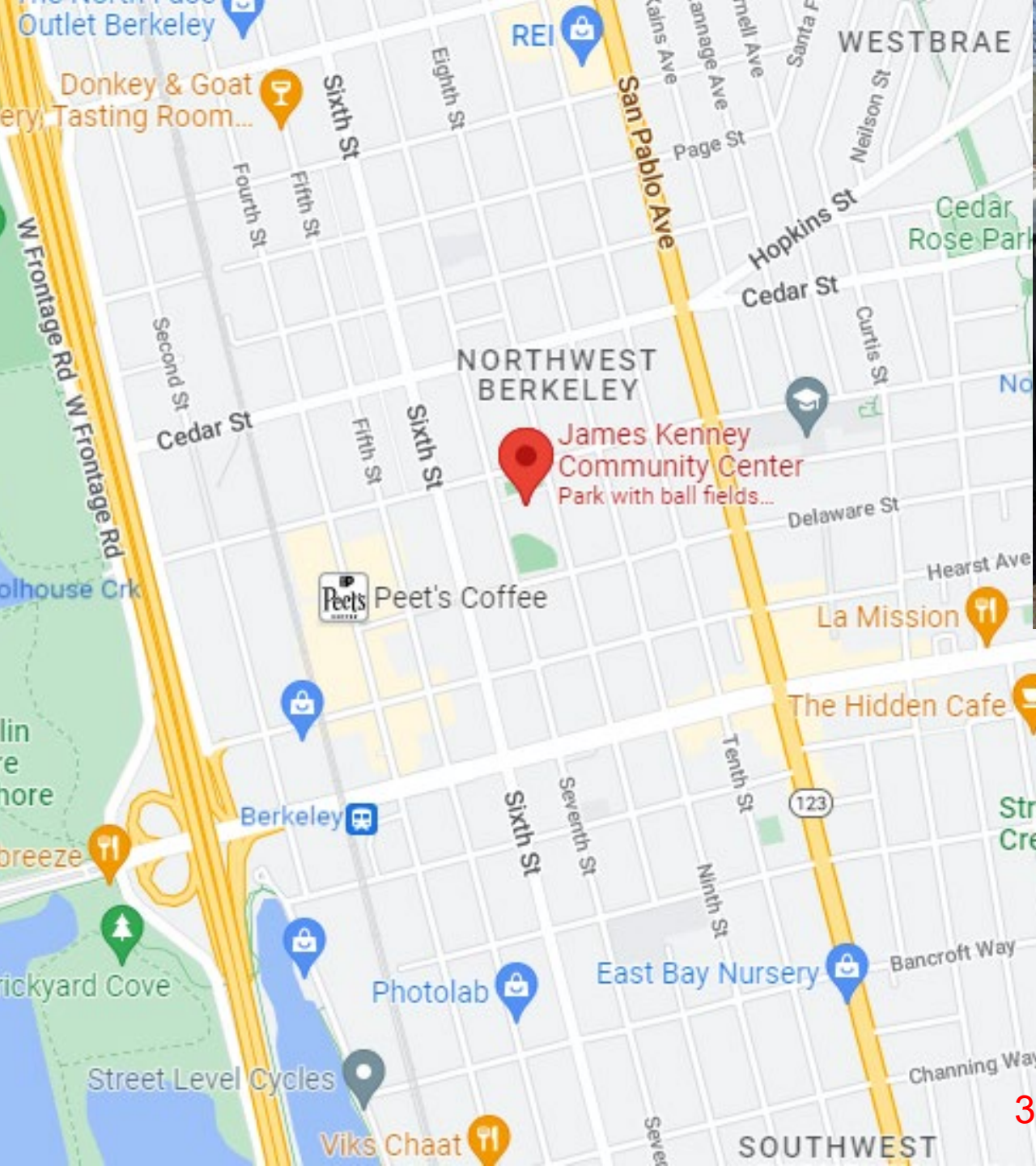

# Original Design – Approved 9/28/2022



# Revised Design For Approval by Civic Arts Commission – March 15, 2023





# 2024/25 Poet Laureate

City of Berkeley | Civic Arts | Berkeley Public Library

---

*APPLY HERE*

---

## Important Dates (Subject to change)

Applications Open	July 1, 2023
Application Deadline	September 1, 2023, 11:59 pm
Selection Panel Meeting	November 2023
Civic Arts Commission Meeting – Poet Laureate Approval	December 6, 2023, 6:00 pm
Appointment Service Term	January 1, 2024 – December 31, 2025
Service Reflection Due	March 1, 2025

## 1. OVERVIEW

### 1.1 Purpose

Civic Arts Mission? Library Mission?

EXAMPLE: The Purpose of the poet laureate pilot program is to champion the art of poetry and spoken word in the City of Durham, and provide free, educational opportunities for all.

EXAMPLE: The Portland Poet Laureate is an honorary position awarded every 3 years to a resident of the Greater Portland area who is both an accomplished poet and an excellent ambassador within the community, helping to promote and win new audiences to the art of poetry.

EXAMPLE: In 2023, Mayor Lori E. Lightfoot, in coordination with the Chicago Public Library, Department of Cultural Affairs and Special Events, and Poetry Foundation, will publicly announce the creation of the Chicago Poet Laureate program. The program comes from the advocacy of the city's creative and civic communities. It aims to increase awareness of Chicago's historic contributions to the literary arts while celebrating and honoring the efforts of Chicago's working artists. The Chicago Poet Laureate will serve a two-year term and be awarded a grant of \$50,000 for the commissioning of new poems, the creation of a public program series, and for serving as an ambassador for the city's literary and creative communities

### 1.2 Pilot Program Background

Joint project of Berkeley Public Library and Civic Arts.

### 1.3 Land Acknowledgment

The City of Berkeley recognizes that the community we live in was built on the territory of xučyun (Huchiun), the ancestral and unceded land of the Chochenyo-speaking Ohlone people, the ancestors and descendants of the sovereign Verona Band of Alameda County. This land was and continues to be of great importance to all of the Ohlone Tribes and descendants of the Verona Band. We acknowledge and honor the original inhabitants of Berkeley, the documented 5,000-year history of a vibrant community at the West Berkeley Shellmound, and the Ohlone people who continue to reside in the East Bay. We recognize that Berkeley's residents have and continue to benefit from the use and occupation of this unceded stolen land since the City of Berkeley's incorporation in 1878. As stewards of the laws regulating the City of Berkeley, it is not only vital that we recognize the history of this land, but also recognize that the Ohlone people are present members of Berkeley and other East Bay communities today. The City of Berkeley will continue to build relationships with the Lisjan Tribe and to create meaningful actions that uphold the intention of this land acknowledgement.

### 1.4 Cultural Equity Statement

The City of Berkeley Civic Arts program commits to equity within the arts and culture sector by consistently evaluating its programs and practices. The City recognizes the multiple benefits the arts provide, regardless of race, color, religion, age, disability, national origin, sex, sexual orientation and gender identity/expression.

Beyond ensuring access to the arts, the City of Berkeley commits to supporting artists and arts organizations that represent diverse cultures, life experiences, and socio-economic backgrounds. The City supports the empowerment of perspectives and identities that have been historically and systemically underrepresented.

### 1.5 Eligibility – Who can apply?

Applicants must meet all of the following eligibility requirements:

- Applicant is an individual poet and *not* applying as a partnership, group, or collective
- Applicant's primary residence is in the City of Berkeley
- Applicant has been a resident of Berkeley for at least two years
- Applicant is 18 years of age or older

### 1.6 Eligibility – Who can't apply?

- City of Berkeley employees employed at the time of the application or during any part of the Service Term
- Full-time students enrolled at the time of the application or during any part of the Service Term
- Individuals who do not live in the City of Berkeley
- Organizational applicants (for example, festivals, nonprofit organizations, businesses, etc.)

### 1.7 Who is encouraged to apply?

Although not considered in review process, individuals representing systemically marginalized identities, including but not limited to: Arab, MENASA (Middle Eastern, North African, South Asian); Asian; Black, African American; California Native American, Indigenous, Tribal; Disabled; Elders, Seniors; Latinx, Chicanx; LGBTQIA2S+; Low Income; Neuro-Divergent; Pacific Islander; People of Color; Trans and/or Non-Binary People; Immigrants (Documented and/or Undocumented), Refugees, Asylum Seekers, Migrants; Unhoused; Unsheltered; Veterans; or Youth 18 years of age or older are strongly encouraged to apply.

## 1.8 Honorarium

The City of Berkeley Poet Laureate will receive a **\$10,000** honorarium for the two-year Service Term.

The full honorarium will be split into two payments. A \$5,000 payment will be made to the appointee in January 2024, and another \$5,000 will be made in January 2025.

## 1.9 Honorarium Use Restrictions

The honorarium may not be used for the following:

- Political advocacy or lobbying

## 1.10 Service Requirements

All service requirements must be completed within the two-year Service Term.

- Produce one (1) original poem related to Berkeley
- Participate in at least four (4) public readings
  - One of these public readings must be coordinated in partnership with the Berkeley Public Library
- Provide coaching and guidance to any Berkeley high schoolers participating in the statewide Poetry Out Loud competition
  - ----support youth poet laureate
  - Provide mentorship to Berkeley's Youth Poet Laureate
- Participate in a video recording of poetry readings for Civic Arts and Berkeley Public Library use
- Be "on-call" for various Mayoral and City Council events – possibly remove or define better "on call"
  - One dignitary event?
- Serve as a Selection Panelist for the next Poet Laureate application process

## 2. APPLICATION PROCESS

### 2.1 Application Materials

All application materials must be submitted electronically before the deadline. The Poet Laureate application consists of the following components:

- Proof of residency
  - Applicants must submit paperwork demonstrating Berkeley residency with their application. Unhoused and unsheltered artists may provide a letter from a Berkeley-based shelter or a Berkeley-based homeless service program as proof of Berkeley residency.
- Resume or Curriculum Vitae (C.V.)
- Work samples and descriptions
- Narrative Questions
- Letters of Support

### 2.2 Application Management System

All application materials must be submitted electronically using the Office of Economic Development's grants management system, [Submittable](#). Technical assistance creating a Submittable account is available through [Submittable's Customer Support](#).

Please note: Paper or physical applications are not accepted at this time.

### 2.3 Technical Assistance

Technical assistance for program-specific inquiries is available from Civic Arts staff by email or by appointment. This technical assistance can help provide guidance around eligibility, service requirements, or review criteria.

Staff contact: Hilary Amnah, Grants Program Lead  
[hamnah@cityofberkeley.info](mailto:hamnah@cityofberkeley.info)  
[Schedule a virtual appointment](#)

### 2.4 Accommodations for Disabilities

Individuals with disabilities who need reasonable accommodations to participate should make their requests to the Civic Arts staff at [civicarts@cityofberkeley.info](mailto:civicarts@cityofberkeley.info). Staff will work with the Disability Compliance Program ([ada@cityofberkeley.info](mailto:ada@cityofberkeley.info)) to review and fulfill the request. Disability-related accommodation requests must be made at least 72 hours in advance of deadlines or meetings. TTY users can dial 7-1-1 to be connected to a specially trained communications assistant from a [state relay provider](#).

### 2.5 Translation Services

The program guidelines are available to be translated into another language upon request. Requests can be emailed to Civic Arts staff at [civicarts@cityofberkeley.info](mailto:civicarts@cityofberkeley.info). If the application is submitted in a language other than English, a third-party translation service will be used to translate application answers into English for Selection Panelists.



### 3. EVALUATION AND SCORING

#### 3.1 Review Criteria

Applications will be evaluated in a Selection Panel meeting according to the following criteria:

##### Literary Practice and Experience (50%)

- Work samples demonstrate high-quality artistry and command of poetry as a craft
- Resume or Curriculum Vitae (C.V.) demonstrates exceptional accomplishments through literary experience and achievements
- Reasoning for how the Poet Laureate appointment will enhance, develop, and/or transform the applicant’s artistic practice is compelling

##### Cultural Equity (25%)

- Applicant clearly conveys how their personal experiences and/or identities are rooted in and reflective of historically marginalized communities.
- Applicant demonstrates an appropriate relationship between their creative practice and a historically marginalized community(ies)
- Applicant’s artistic voice is representative and a reflection of Berkeley’s diverse identities

##### Community and Civic Engagement (25%)

- At least one venue, broadcast format, or virtual platform is identified for a public reading; feasibility of using identified venue is articulated
- Proposed public reading engages a defined Berkeley audience/community in a meaningful way
- Applicant demonstrates a track record of community engagement and collaboration in Berkeley, including hosting events, organizing, teaching, leading workshops, and/or creative outreach

#### 3.2 Scoring Scale

Selection Panelists use the following scale in assessing how well the applicant meets the review criteria. Numerical values are then translated to the appropriate weight for each criterion.

5	<b>Exceptional</b>	meets review criteria to the highest degree
4	<b>Strong</b>	strongly meets review criteria
3	<b>Good</b>	satisfactorily or successfully meets review criteria; average
2	<b>Fair</b>	moderately meets some of the review criteria; needs some improvement
1	<b>Underdeveloped</b>	minimally meets the review criteria; greatly needs improvement
0	<b>Weak</b>	does not meet any elements of the review criteria

## 4. REVIEW PROCESS

### 4.1 Eligibility Screening

Civic Arts staff will review each application submitted before the deadline for eligibility and completeness. Eligible applications will be evaluated by a Selection Panel for scoring in accordance with the review criteria.

### 4.2 Selection Panel

The Selection Panel is comprised of individuals located in the greater Bay Area with diverse backgrounds in the literary arts field.

#### Council Member or Mayor?

Any Selection Panelist who has a conflict of interest with an application(s) must recuse themselves from reviewing that application(s). A 'conflict of interest' is defined as a situation in which a Selection Panelist has a competing professional, financial, or personal interests that might could impair their ability to perform their evaluation responsibilities objectively.

The Selection Panel meeting is public and facilitated through a Zoom Video Webinar. All applicants receive information regarding the panel meeting's date, time, and order in which applications will be reviewed. Applicants are encouraged to attend the panel meeting.

Applicants are permitted three (3) minutes at the end of the panel's review of their application to clarify any aspects of the application that may have been misunderstood by the panelists. The three minutes to address the panelists may not be used to give additional information not included in the application.

Panel comments made by panelists in support of their scores are available to applicants upon request once they receive the official notice of their application's award or decline from Civic Arts.

### 4.3 Civic Arts Commission Approval

After the Selection Panel has scored all applications and made a final decision on the appointee, Civic Arts staff will present panel results in a Civic Arts Commission meeting. The Civic Arts Commission approves the Poet Laureate before the official appointment is made.

## 5. POET LAUREATE REQUIREMENTS AND POLICIES

### 5.1 Invoicing

The Poet Laureate must complete a Demographic Survey to receive their honorarium invoice from **Berkeley Public Library**. Staff will provide an invoice for \$5,000 in January of 2024, and other invoice for \$5,000 in January of 2025

Please note: Appointees should be aware of the tax implications upon receiving the award and maintain documents required for state and federal income taxes.

### 5.2 Selection Panel Service

The Poet Laureate is required to serve as a Selection Panelist for the next application cycle of the Poet Laureate Program. The service will be completed in November of the second year of the Service Term.

### 5.3 Service Reflection

A completed Service Reflection form is due within 60 days after the end of the Service Term. Service Reflections are usually due by March 1 unless otherwise noted. The Service Reflection should outline completed activities and achievements during the Service Term. It also includes evaluation questions for self-reflection and for Civic Arts staff to make improvements to the program. **Poets Laureate who do not submit a Final Report are ineligible from applying for future Poet Laureate appointments.**

### 5.4 Poetry Video Recording

Individual Artist Project grantees are required to participate in a virtual Artist Showcase to present their final project processes and products as a cohort. The Artist Showcase is an opportunity to see other grantees' work and share their work with the Civic Arts community. The Artist Showcase may be recorded and used for Civic Arts promotional purposes.

### 5.5 Notifying Civic Arts and Library Staff about Public Engagements

It is important that the Berkeley community know that their local tax dollars make it possible for them to enjoy the caliber of arts produced in Berkeley. Grant recipients should acknowledge the City's financial support by using the phrase "Supported in part by a Civic Arts Grant from the City of Berkeley" or including the "City of Berkeley" in lists of supporters. Grantees must display the [City's logo](#) in all promotional materials and media. (Civic Arts Contact & Library Contact) – promotional opportunity

### 5.6 City Permits and Permissions

A Poet Laureate appointment does not imply that the City will produce, exhibit, or promote artwork(s) created with during the Service Term. It is the responsibility of the Poet Laureate to secure venues and appropriate insurance for public presentations.

The Poet Laureate solely responsible for securing the necessary City permits or approvals for elements such as publicly installed art, street closures, sound amplification in public space, or murals if included as part of the grant proposal. – check with Jen

### 5.7 Incomplete Service Requirements

Poets Laureate who do not complete all service requirements during the Service Term may need to return their honorarium to the City of Berkeley.



# Community for a Cultural Civic Center

March 6, 2023

Dear Mayor and City Council,

The Community for a Cultural Civic Center (the “4Cs”) wants to thank you for approving a motion at your January 31 special meeting to align priorities that continue to protect and support the Turtle Island Monument Project and its Phase 2 T1 Funding of \$300,000.

Our group continues to support the Turtle Island Monument Project process under the direction of the Landmarks Preservation, Civic Arts, and Parks, Recreation & Waterfront Commissions. We encourage staff, commissions, and the Council to move forward as quickly as possible with cost and engineering studies, and to begin implementation of this project, which is important to both the Indigenous community and the wider Berkeley community.

Sincerely,

John Caner  
Convener, [Community for a Cultural Civic Center](#)

Cc: Landmarks Preservation; Civic Arts; Parks, Recreation & Waterfront Staff and Commissions