



Office of the City Manager

INFORMATION CALENDAR

October 29, 2019

To: Honorable Mayor and Members of the City Council

From: Dee Williams-Ridley, City Manager

Submitted by: Timothy Burroughs, Director, Planning and Development

Subject: LPO NOD: 2018-36 University Avenue/#LMSAP2019-0002 for the UC Theater Building

INTRODUCTION

The attached Landmarks Preservation Commission Notice of Decision (NOD) is presented to the Mayor and City Council pursuant to Berkeley Municipal Code/Landmarks Preservation Ordinance (BMC/LPO) Section 3.24.240.A, which requires that “a copy of the Notice of Decision shall be filed with the City Clerk, and the City Clerk shall present said copy to the City Council at its next regular meeting.”

CURRENT SITUATION AND ITS EFFECTS

The Landmark Preservation Commission (LPC/Commission) has approved a Structural Alteration Permit (SAP) for the subject City Landmark property. This action is subject to an appeal period which began on October 15, 2019.

BACKGROUND

BMC/LPO Section 3.24.300 allows City Council to review any action of the Landmarks Preservation Commission in granting or denying a Structural Alteration Permit. In order for Council to review the decision on its merits, Council must appeal the Notice of Decision. To do so, a Council member must move this Information Item to Action and then move to set the matter for hearing on its own. Such action must be taken within 15 days of the mailing of the Notice of Decision, or by October 30, 2019. Such certification to Council shall stay all proceedings in the same manner as the filing of an appeal.

If the Council chooses to appeal the action of the Commission, then a public hearing will be set. The Council must rule on the application within 30 days of closing the hearing, otherwise the decision of the Commission is automatically deemed affirmed.

Unless the Council wishes to review the determination of the Commission and make its own decision, the attached NOD is deemed received and filed.

ENVIRONMENTAL SUSTAINABILITY

Landmark designation provides opportunities for the adaptive re-use and rehabilitation of historic resources within the City. The rehabilitation of these resources, rather than their removal, achieves construction and demolition waste diversion, and promotes investment in existing urban centers.

POSSIBLE FUTURE ACTION

The Council may choose to appeal the decision, in which case it would conduct a public hearing at a future date.

FISCAL IMPACTS OF POSSIBLE FUTURE ACTION

There are no known fiscal impacts associated with this action.

CONTACT PERSON

Timothy Burroughs, Director, Planning and Development Department, 510-981-7401  
Fatema Crane, Landmarks Preservation Commission Secretary, Planning and Development, 510-981-7413  
Alison Lenci, Assistant Planner, Planning and Development, 510-981-7544

Attachments:

1: Notice of Decision – #LMSAP2019-0002 for 2018-36 University Avenue



L A N D M A R K S  
P R E S E R V A T I O N  
C O M M I S S I O N

---

N O T I C E O F D E C I S I O N

**DATE OF BOARD DECISION: August 1, 2019**  
**DATE NOTICE MAILED: October 15, 2019**  
**APPEAL PERIOD EXPIRATION: October 30, 2019**  
**EFFECTIVE DATE OF PERMIT (Barring Appeal or Certification): October 31, 2019<sup>1</sup>**

## **2018-36 University Avenue – The UC Theater Building**

**Structural Alteration Permit #LMSAP2019-0005 to complete storefront improvements and establish a signage program on a portion of a City Landmark building.**

The Landmarks Preservation Commission of the City of Berkeley, **APPROVED** the Structural Alteration Permit for this project.

**APPLICANT:** Brad Gunkel, Gunkel Architecture, 2295 San Pablo Avenue, Berkeley, CA 94702

**ZONING DISTRICT:** C-DMU Core, Downtown Mixed-Use Core

**ENVIRONMENTAL REVIEW STATUS:** Categorically exempt from environmental review pursuant to Section 15331 of the CEQA Guidelines for Historical Resource Rehabilitation.

**The Application materials for this project are available online at:**  
<http://www.cityofberkeley.info/zoningapplications>

---

### **FINDINGS, CONDITIONS AND APPROVED PLANS ARE ATTACHED TO THIS NOTICE**

<sup>1</sup> Pursuant to BMC Section 1.04.070, if the close of the appeal period falls on a weekend or holiday, then the appeal period expires the following business day. Pursuant to BMC Section 3.24.190, the City Council may “certify” any decision of the LPC for review, within fifteen days from the mailing of the NOD. Such certification shall stay all proceedings in the same manner as the filing of a notice of appeal.

LANDMARKS PRESERVATION COMMISSION  
NOTICE OF DECISION  
LMSAP2019-0002  
2018-36 University Avenue  
October 11, 2019  
Page 2 of 4

---

**COMMISSION VOTE: 6-0-1-1**

**YES:** ABRANCHAS DA SILVA, ALLEN, CHAGNON, CRANDALL, FINACOM, OLSON

**NO:** None

**ABSTAIN:** O'MALLEY

**ABSENT:** SCHWARTZ

**TO APPEAL THIS DECISION (see Section 3.24.300 of the Berkeley Municipal Code):**

To appeal a decision of the Landmarks Preservation Commission to the City Council you must:

1. Submit a letter clearly and concisely setting forth the grounds for the appeal to the City Clerk, located at 2180 Milvia Street, 1st Floor, Berkeley. The City Clerk's telephone number is (510) 981-6900.
  - a. Pursuant to BMC Section 3.24.300.A, an appeal may be taken to the City Council by the application of the owners of the property or their authorized agents, or by the application of at least fifty residents of the City aggrieved or affected by any determination of the commission made under the provisions of Chapter 3.24.
2. Submit the required fee (checks and money orders must be payable to 'City of Berkeley'):
  - a. The basic fee for persons other than the applicant is \$500. This fee may be reduced to \$100 if the appeal is signed by persons who lease or own at least 50 percent of the parcels or dwelling units within 300 feet of the project site, or at least 25 such persons (not including dependent children), whichever is less. Signatures collected per the filing requirement in BMC Section 3.24.300.A may be counted towards qualifying for the reduced fee, so long as the signers are qualified. The individual filing the appeal must clearly denote which signatures are to be counted towards qualifying for the reduced fee.
  - b. The fee for appeals of affordable housing projects (defined as projects which provide 50 percent or more affordable units for households earning 80% or less of Area Median Income) is \$500, which may not be reduced.
  - c. The fee for all appeals by Applicants is \$2500.
3. The appeal must be received prior to 5:00 p.m. on the "APPEAL PERIOD EXPIRATION" date shown above (if the close of the appeal period falls on a weekend or holiday, then the appeal period expires the following business day).

If no appeal is received, the landmark designation will be final on the first business day following expiration of the appeal period.



LANDMARKS PRESERVATION COMMISSION  
NOTICE OF DECISION  
LMSAP2019-0002  
2018-36 University Avenue  
October 11, 2019  
Page 3 of 4

**STRUCTURAL ALTERATION PERMIT ISSUANCE:**

If no appeal is received, the Structural Alteration permit will be issued on the first business day following expiration of the appeal period, and the project may proceed at that time. Information about the Building Permit process can be found at the following link:

<http://www.ci.berkeley.ca.us/permitservicecenter/>.

**NOTICE CONCERNING YOUR LEGAL RIGHTS:**

---

If you object to this decision, the following requirements and restrictions apply:

1. If you challenge this decision in court, you may be limited to raising only those issues you or someone else raised at the public hearing described in this notice, or in written correspondence delivered to the Landmarks Preservation Commission at, or prior to, the public hearing.
2. You must appeal to the City Council within fifteen (15) days after the Notice of Decision of the action of the Landmarks Preservation Commission is mailed. It is your obligation to notify the Land Use Planning Division in writing of your desire to receive a Notice of Decision when it is completed.
3. Pursuant to Code of Civil Procedure Section 1094.6(b) and Government Code Section 65009(c)(1), no lawsuit challenging a City Council decision, as defined by Code of Civil Procedure Section 1094.6(e), regarding a use permit, variance or other permit may be filed more than ninety (90) days after the date the decision becomes final, as defined in Code of Civil Procedure Section 1094.6(b). Any lawsuit not filed within that ninety (90) day period will be barred.
4. Pursuant to Government Code Section 66020(d)(1), notice is hereby given to the applicant that the 90-day protest period for any fees, dedications, reservations, or other exactions included in any permit approval begins upon final action by the City, and that any challenge must be filed within this 90-day period.
5. If you believe that this decision or any condition attached to it denies you any reasonable economic use of the subject property, was not sufficiently related to a legitimate public purpose, was not sufficiently proportional to any impact of the project, or for any other reason constitutes a "taking" of property for public use without just compensation under the California or United States Constitutions, your appeal of this decision must including the following information:
  - A. That this belief is a basis of your appeal.
  - B. Why you believe that the decision or condition constitutes a "taking" of property as set forth above.
  - C. All evidence and argument in support of your belief that the decision or condition constitutes a "taking" as set forth above.

If you do not do so, you will waive any legal right to claim that your property has been

LANDMARKS PRESERVATION COMMISSION  
NOTICE OF DECISION  
LMSAP2019-0002  
2018-36 University Avenue  
October 11, 2019  
Page 4 of 4

taken, both before the City Council and in court.

**PUBLIC COMMENT:**

---

Communications to Berkeley boards, commissions or committees are public record and will become part of the City's electronic records, which are accessible through the City's website. **Please note: e-mail addresses, names, addresses, and other contact information are not required, but if included in any communication to a City board, commission or committee, will become part of the public record.** If you do not want your e-mail address or any other contact information to be made public, you may deliver communications via U.S. Postal Service or in person to the secretary of the relevant board, commission or committee. If you do not want your contact information included in the public record, please do not include that information in your communication. Please contact the secretary to the relevant board, commission or committee for further information.

**FURTHER INFORMATION:**

---

Questions about the project should be directed to the project planner, Alison Lenci, at (510) 981-7544 or [alenci@cityofberkeley.info](mailto:alenci@cityofberkeley.info). All project application materials, including full-size plans, may be viewed at the Permit Service Center (Zoning counter), 1947 Center Street, between 8 a.m. and 4 p.m., Monday through Friday.

**ATTACHMENTS:**

---

1. Approved Findings and Conditions
2. Project Plans, received **JULY 17, 2019**
3. Colors and Materials, received **FEBRUARY 6, 2019**

ATTEST:   
Fatema Crane, Secretary  
Landmarks Preservation Commission

cc: City Clerk  
Applicant: Brad Gunkel  
Gunkel Architecture  
2295 Pablo Avenue  
Berkeley, CA 94702  
  
Owner: SB Pacific Group, LLC  
2295 San Pablo Avenue  
Berkeley, CA 94702

# ATTACHMENT 1, PART 2

---

## FINDINGS AND CONDITIONS

### 2018-36 University Avenue – The UC Theater Building

#### Structural Alteration Permit #LMSAP2019-0002

To complete storefront improvements and establish a signage program on a portion of a City Landmark building.

#### CEQA FINDINGS

---

1. The project is categorically exempt from the provisions of the California Environmental Quality Act (CEQA, Public Resources Code §21000, et seq. and California Code of Regulations, §15000, et seq.) pursuant to Section 153331 of the CEQA Guidelines (“Historic Resource Restoration/Rehabilitation”). Furthermore, none of the exceptions in CEQA Guidelines Section 15300.2 apply, as follows: (a) the site is not located in an environmentally sensitive area, (b) there are no cumulative impacts, (c) there are no significant effects, (d) the project is not located near a scenic highway, (e) the project site is not located on a hazardous waste site pursuant to Government Code Section 65962.5, and (f) the project will not affect any historical resource.

#### SECRETARY OF THE INTERIOR’S STANDARDS FINDINGS

---

Regarding the Secretary of the Interior’s Standards for Rehabilitation, the Landmarks Preservation Commission of the City of Berkeley makes the following findings:

1. The property was historically a movie theater with a two-part commercial and residential component. The movie theater has since closed and operates as a music venue. Minimal change to the building’s distinctive materials, features, spaces, and spatial relationships of the site are proposed.
2. The proposal to add awnings and establish a signage program for the tenant spaces will not result in removal of distinctive materials or alterations that will significantly change the overall spatial relations that characterize the building (e.g. mass, height).
3. Owing to their contemporary design and selection of materials, the proposed new features, including awnings and signage, will be recognizable as present-day elements of the building and will not be confused as original or historic, nor will they create a false sense of history.
4. The project will remove alterations whose design and materials are not consistent with the original design nor historically significant in their own right. Alterations to the building that will be removed include: covering transoms, applied finishes to exposed

brick and columns; installation of various building signage, light fixtures and electrical boxes and conduit.

5. No such materials, features, finishes or techniques will be affected by this proposal.
6. The project will restore and repair features that have deteriorated or been removed, including repairing the column/spandrel, column base and existing entry way, re-grouting the mortar joint and applying sealer to the brick piers, and restoring the brick material to its original condition by removing applied finishes.
7. If approved, this project will be subject to a condition that ensures only the gentlest measures are employed when chemical treatments are required.
8. Because no excavation will be required for the proposed alteration of this building, any existing archeological resources at this site will be unaffected by this proposal.
9. The proposed exterior alterations will not destroy features and spatial relationships that characterize the subject property, as described previously in the Analysis for SOI Standard 2, above.
10. The new awnings and signage are limited and will not alter the overall form of the building. All other work proposed with this project will restore original historic features which have been removed, altered or deteriorated over time. If the new awnings and signage were removed in the future, the essential form and integrity of the historic property and its environment will be unimpaired.

### **LANDMARK PRESERVATION ORDINANCE FINDINGS**

1. As required by Section 3.24.260 of the Landmarks Preservation Ordinance, the Commission finds that proposed work is appropriate for and consistent with the purposes of the Ordinance, and will preserve and enhance the characteristics and features specified in the designation for this property. Specifically:
  - The proposal maintains the form and scale of the UC Theater building, including the six storefronts, as well as the uses within the building.
  - The proposed work will not adversely affect the exterior architectural features of the Landmark, the special character or historical, architectural or aesthetic interest or value of the Landmark and its site because the project will restore historic, character defining features which have been removed, altered or deteriorated over time, including exposed brickwork, windows, and storefront bay fenestration elements, and the new work (e.g. awnings and signage) on the storefronts will not over-shadow or conflict with the integrity of the historic public façade of the UC Theater building.

### **STANDARD CONDITIONS**

The following conditions, as well as all other applicable provisions of the Landmarks Preservation Ordinance, apply to this Permit:

1. **Conditions Shall be Printed on Plans**

The conditions of this Permit shall be printed on the *second* sheet of each plan set submitted for a building permit pursuant to this Permit, under the title 'Structural Alteration Permit Conditions'. *Additional sheets* may also be used if the *second* sheet is not of sufficient size to list all of the conditions. The sheet(s) containing the conditions shall be of the same size as those sheets containing the construction drawings; 8-1/2" by 11" sheets are not acceptable.

## 2. Plans and Representations Become Conditions

Except as specified herein, the site plan, floor plans, building elevations and/or any additional information or representations, whether oral or written, indicating the proposed structure or manner of operation submitted with an application or during the approval process are deemed conditions of approval.

## 3. Subject to All Applicable Laws and Regulations

The approved use and/or construction is subject to, and shall comply with, all applicable City Ordinances and laws and regulations of other governmental agencies. Prior to construction, the applicant shall identify and secure all applicable permits from the Building and Safety Division, Public Works Department and other affected City divisions and departments.

## 4. Exercise and Lapse of Permits (Section 23B.56.100)

- B. A permit for the construction of a building or structure is deemed exercised when a valid City building permit, if required, is issued, and construction has lawfully commenced.
- A. A permit may be declared lapsed and of no further force and effect if it is not exercised within one year of its issuance, except that permits for construction or alteration of structures or buildings may not be declared lapsed if the permittee has:
  - (1) applied for a building permit; or, (2) made substantial good faith efforts to obtain a building permit and begin construction, even if a building permit has not been issued and/or construction has not begun.

## 5. Indemnification Agreement

The applicant shall hold the City of Berkeley and its officers harmless in the event of any legal action related to the granting of this Permit, shall cooperate with the City in defense of such action, and shall indemnify the City for any award of damages or attorneys fees that may result.

## **ADDITIONAL CONDITIONS**

---

The following additional conditions are attached to this Permit:

- 6. **Chemical Treatments.** Any chemical treatments needed as construction progresses will be undertaken using the gentlest means possible.
- 7. **Anchors.** Anchors in the historical façade shall be as discreet as possible and patched when signage or awnings are removed.

8. **Unobscured glazing.** At all times, all storefront doors and window glazing shall remain unobscured and shall not contain signage, text, photos, posters or other applications or objects, other than one directional window sign of 8 sq. ft. or less, per storefront, and a numeric street address, which may be installed only as required for public safety.
9. **Clear glass.** All glass is assumed to be clear glass. Any proposed glass that is not clear glass shall be indicated on all drawings, and shall be reviewed for approval by historic preservation staff, prior to approval of any building permit for this project.
10. **Colors.** Prior to staff sign-off of the building permit set of drawings, the applicant shall submit color and materials information for review and approval by historic preservation staff.
11. **Details.** Prior to staff sign-off of the building permit set of drawings, the applicant shall submit window, door, base, and trim details for review and approval by historic preservation staff.
12. **Lighting.** All exterior lighting, including for signage, shall be shielded and directed downward and away from property lines to prevent excessive glare beyond the subject property.
13. **Signage Program.** Prior to staff sign-off of the building permit set of drawings, the applicant shall submit complete signage details for the awning signage and projecting blade signs, including colors, materials, letter heights, dimensions, placement on building, and installation details. All materials shall be matte unless otherwise noted.
14. **Recessed Storefront Doors.** Plans submitted for building permit shall show that the face of each storefront door shall be recessed a minimum of 12" from the wall plane. Prior to staff sign-off of the building permit set of drawings, the applicant may request a reduction to a recess of no less than 8", provided adequate documentation is provided to show that a recess of 12" would result in fire, life, safety constraints (i.e. issues meeting building code, fire code, structural or ADA requirements).
15. **Storefront Window Pane.** Plans submitted for building permit shall show that the storefront window on the tenant space furthest east, at 2030 University Avenue, shall be a three-pane window.



# EXTERIOR ELEVATION RENOVATION

2018-2030 UNIVERSITY AVE.  
BERKELEY, CA 94704

## SYMBOLS

HEIGHT		DETAIL	
SECTION		GRID LINE	
EXTERIOR ELEVATION		DEMOLITION NOTE	
INTERIOR ELEVATION		IMPROVEMENT NOTE	

## ABBREVIATIONS

A.B./ANCHOR BOLT ABV./ABOVE A.C./ASPHALTIC CONCRETE A.C.T./ACOUSTICAL CEILING TILE	DECK./DECKING DEG./DEGREE DEMO./DEMOLITION DEPT./DEPARTMENT DET./DETAIL D.F./DRINKING FOUNTAIN DIA./DIAMETER DIM./DIMENSION DIR./DIRECTION DISP./DISPOSAL DIST./DISTRIBUTION DIV./DIVISION DN./DOWN DR./DOOR D.S./DOWNSPOUT D.S.A./ DIVISION OF STATE ARCHITECT D.S.P./DRY STAND PIPE DWG./DRAWING	F.O.W./FACE OF WALL FPRF./FIREPROOF(ING) FRM./FRAMING F.R.T./FIRE RETARDANT TREATED F.R.P./FIBERGLASS REINFORCED POLYESTER F.S./FLOOR SINK F.S.E./FOOD SERVICE EQUIPMENT FT./FOOT OR FEET FTG./FOOTING FURR./FURRING FUT./FUTURE	L.L.H./LONG LEG HORIZONTAL L.P./LOW POINT LT./LIGHT LVR./LOUVER	PLAS./PLASTER PLBG./PLUMBING PLYVD./PLYWOOD PNL./PANEL PR./PAIR PREP./PREPARATION P.S.F./POUNDS PER SQUARE FOOT P.S.I./POUNDS PER SQUARE INCH P.T./PRESSURE TREATED PT./POINT P.T.D./PAPER TOWEL DISPENSER PTN./PARTITION PVC/POLYVINYL CHLORIDE PVMT./PAVEMENT	AIR CONDITIONING CONTRACTORS NATIONAL ASSOCIATION DRAWINGS S.M.D./SEE MECHANICAL DRAWINGS S.M.S./SHEET METAL SCREW S.N.D./ SANITARY NAPKIN DISPENSER S.N.R./SANITARY NAPKIN RECEPTACLE S.O.G./SLAB ON GRADE S.P.D./SEE PLUMBING DRAWINGS SPEC./SPECIFICATION SPR./SPRINKLERED S.P.S./SEE PARTITION SCHEDULE SQ./SQUARE S.S.D./SEE STRUCTURAL DRAWINGS STD./STANDARD STL./STEEL STR./STRUCTURAL S4S/SURFACE FOUR SIDES S2S/SURFACE TWO SIDES S3S/STAINLESS STEEL SVC/SERVICE STOR./STORAGE SUSP./SUSPENDED S.W./SOUTHWEST S.W.S./SEE WINDOW SCHEDULE T./TREAD T.B./TACKBOARD TECH./TECHNOLOGY TELE./TELEPHONE TEMP./TEMPERED or TEMPERATURE TER./TERRAZZO T & G/TONGUE & GROOVE THK./THICK THRES./THRESHOLD T.O./TOP OF T.O.C./TOP OF CURB or CONCRETE T.O.D./TOP OF DECKING T.O.M./TOP OF MASONRY T.O.P./TOP OF PAVEMENT or PARAPET T.O.S./TOP OF STEEL T.O.W./TOP OF WALL T.S./TUBULAR STEEL T.S.C.D./TOILET SEAT COVER DISPENSER T.T.D./TOILET TISSUE DISPENSER TV/TELEVISION TYP./TYPICAL U.B.C./UNIFORM BUILDING	CODE U.G./UNDERGROUND U.L./UNDERWRITERS LABORATORY UNF./UNFINISHED U.O.N./UNLESS OTHERWISE NOTED UR./URINAL V.C.T./VINYL COMPOSITION TILE VERT./VERTICAL VEST./VESTIBULE V.G.D.F./VERTICAL GRAIN DOUGLAS FIR V.I.F./VERIFY IN FIELD VOL./VOLUME V.T.R./VENT THRU ROOF (S.P.D.) V.W.C./VINYL WALL COVERING W./WEST OR WASHER W/ WITH W.C./WATER CLOSET WD/WASHER/DRYER WD./WOOD WDW./WINDOW W.F./WIDE FLANGE WGL/WIRE GLASS W.H./WATER HEATER W.I.C./WOODWORK INSTITUTE OF CALIFORNIA W.O./WHERE OCCURS W.O/WITHOUT W.P./WORKING POINT WSCT./WAINSCOT W.S.P./WET STANDPIPE WT./WEIGHT W.W.F./WELDED WIRE FABRIC
---	---	--	--	--	--	--

## PROJECT TEAM

### OWNER

SB PACIFIC GROUP, LLC  
2295 San Pablo Avenue  
Berkeley, CA 94702

## CODE COMPLIANCE

2016 CALIFORNIA BUILDING CODE (INCORPORATES BY ADOPTION AND REPRINTS THE 2015 INTERNATIONAL BUILDING CODE WITH CALIFORNIA AMENDMENTS. PUBLISHED BY THE INTERNATIONAL CODE COUNCIL, ICC)

2016 CALIFORNIA RESIDENTIAL CODE - APPLIES TO ONE AND TWO FAMILY HOUSES AND TOWNHOMES LESS THAN 3 STORIES IN HEIGHT. (INCORPORATES BY ADOPTION AND REPRINTS THE 2015 INTERNATIONAL RESIDENTIAL CODE)

2016 CALIFORNIA ENERGY CODE - CHECK THE CALIFORNIA ENERGY COMMISSION'S WEBSITE AT [HTTP://WWW.ENERGY.CA.GOV](http://www.energy.ca.gov) FOR A DOWNLOADABLE VERSION. (PUBLISHED BY ICC).

2016 CALIFORNIA ELECTRICAL CODE (INCORPORATES BY ADOPTION AND REPRINTS THE 2014 NATIONAL ELECTRICAL CODE WITH CALIFORNIA AMENDMENTS. PUBLISHED BY THE NATIONAL FIRE PROTECTION AGENCY, NFPA)

2016 CALIFORNIA PLUMBING CODE (INCORPORATES BY ADOPTION AND REPRINTS THE 2015 UNIFORM PLUMBING CODE WITH CALIFORNIA AMENDMENTS. PUBLISHED BY THE INTERNATIONAL ASSOCIATION OF PLUMBING AND MECHANICAL OFFICIALS, IAPMO)

2016 CALIFORNIA MECHANICAL CODE (INCORPORATES BY ADOPTION AND REPRINTS THE 2015 UNIFORM MECHANICAL CODE WITH CALIFORNIA AMENDMENTS. PUBLISHED BY THE INTERNATIONAL ASSOCIATION OF PLUMBING AND MECHANICAL OFFICIALS, IAPMO)

2016 CALIFORNIA FIRE CODE (INCORPORATES BY ADOPTION AND REPRINTS THE 2015 INTERNATIONAL FIRE CODE WITH CALIFORNIA AMENDMENTS. PUBLISHED BY ICC)

2016 CALGREEN CODE - APPLIES TO CERTAIN NEW BUILDINGS ONLY - ALL NEW RESIDENTIAL BUILDINGS 3 STORIES OR LESS AND ALL NEW NON-RESIDENTIAL BUILDINGS. HERS VERIFICATION REQUIRED BY T-24 ENERGY REPORT.

## ARCHITECT

Gunkel Architecture  
2295 San Pablo Avenue  
Berkeley, CA. 94702  
(510) 984-1112

## DRAWING NOTES

TYPICAL OWNER/DEVELOPER BUILDING PERMIT SET OF DRAWINGS:

THESE DRAWINGS ARE INTENDED FOR BUILDING PERMIT APPROVAL AND ARE NOT INTENDED TO BE A COMPREHENSIVE SET OF DRAWINGS INDICATING CONSTRUCTION DETAILS, WATER PROOFING, SPECIFIC FINISHES, SPECIFIC CABINETRY, SPECIFIC PLUMBING FIXTURES, LIGHTING FIXTURES, SPECIFIC DOORS, WINDOWS, & HARDWARE, OR M.E.P. & UTILITY ROUTING. OWNER/DEVELOPER IS RESPONSIBLE FOR THE SELECTION OF THESE ITEMS AND CLARIFICATION AND COORDINATION OF THESE WITH THE CONTRACTOR AS PART OF THE BUILDING CONTRACT AND CONSTRUCTION PROCESS. CONTRACTOR IS RESPONSIBLE FOR CONFIRMING CODE COMPLIANCE OF ALL WORK NOT FULLY REFLECTED IN THESE DOCUMENTS AS WELL AS ANY REVISIONS TO THIS SCOPE WITH THE ENTITIES HAVING JURISDICTION. CONTRACTOR IS RESPONSIBLE FOR PROVIDING A COMPLETE, STRUCTURALLY SOUND, FULLY OPERATIONAL, CODE COMPLIANT, FINISHED WORK WITH COMPLETE PROTECTION AGAINST ELEMENTS.

## DESCRIPTION OF WORK

RENOVATION OF (E) SINGLE-DWELLING HOUSE. CONVERSION OF GARAGE INTO HABITABLE SPACE, LANDSCAPING & FENCE IMPROVEMENTS.

CAB./CABINET C/C/CENTER TO CENTER CEM./CEMENT CER./CERAMIC C.F./CUBIC FEET CH./CHANNEL C.I./CAST IRON C.J./CONTROL JOINT C.L./CENTERLINE CLG./CEILING CLK.G./CAULKING CLO./CLOSET CLR./CLEAR C.M.U./CONCRETE MASONRY UNIT COL./COLUMN COMP./COMPUTER CONC./CONCRETE CONF./CONFERENCE CABINET CONT./CONTINUOUS CONTR/ FED./FEDERAL CONTRACTOR CONST./ F.V./FIELD VERIFY CONSTRUCTION CORR./CORRIDOR CPT./CARPET C.R./COLD-ROLLED CSMT./CASEMENT C.T./CERAMIC TILE CTR./CENTER CTS.K./COUNTERSUNK C.Y./CUBIC YARDS	E/EAST (E)/EXISTING EA/EACH EJ./EXPANSION JOINT EL/ELEVATION ELAS./ELASTOMERIC ELEC./ELECTRICAL ELEV./ELEVATOR EMER./EMERGENCY ENCL./ENCLOSURE ENGR./ENGINEER EQ./EQUAL EQUIP./EQUIPMENT E.S./EACH SIDE EXP./EXPANSION EXH./EXHAUST EXT./EXISTING EXT./EXTERIOR E.W./EACH WAY	H.B./HOSE BIBB H.C./HOLLOW CORE HDWR./HARDWARE HDWD./HARDWOOD HT./HEIGHT H.M./HOLLOW METAL HORIZ./HORIZONTAL H.P./HIGH POINT HVAC/HEATING, VENTILATING, AIR CONDITIONING I.D./INSIDE DIAMETER IN./INCH INCAND./INCANDESCENT INCR./INCREMENT INFO./INFORMATION INSUL./INSULATION INT./INTERIOR JAN./JANITOR JT./JOIST JT./JOINT KIT./KITCHEN K.P./KICK PL	GA./GAUGE GALV./GALVANIZED G.L.B./GLUE- LAMINATED (WOOD) BEAM GL./GLASS GND./GROUND G.R.G./GLASS REINFORCED GYPSUM G.S.M./GALVANIZED SHEET METAL GYP./GYPSUM G.W.B./GYPSUM WALL BOARD	N./NORTH (N)/NEW N/A/NOT APPLICABLE N.E./NORTHEAST N.I.C./NOT IN CONTRACT NO./NUMBER NOM./NOMINAL N.T.S./NOT TO SCALE N.W./NORTHWEST	SA./SUPPLY AIR S.B./SCOREBOARD S.C./SOLID CORE S.C.D./SEE CIVIL DRAWINGS or DIMENSION S.D./STORM DRAIN S.D.S./SEE DOOR SCHEDULE S.E./SOUTHEAST S.E.D./SEE ELECTRICAL DRAWINGS SECT./SECTION S.F./SQUARE FOOT (FEET) S.F.S./SEE (ROOM) FINISH SCHEDULE SHT./SHEET SHTG./SHEATHING SIM./SIMILAR S.L.D./SEE LANDSCAPE DRAWINGS S.M./SHEET METAL SL./SLOPE SMACNA /SHEET METAL AND	OB.S./OBSCURE O.C./ON CENTER O.D./OUTSIDE DIAMETER or DIMENSION O.F.C./OWNER FURNISHED, CONTRACTOR INSTALLED O.F.D./OVERFLOW DRAIN O.F.S./OVERFLOW SCUPPER O.H./OVER HEAD OPNG./OPENING OPP. HD./ OPPOSITE HAND OZ./OUNCE	P.A./PLANTING AREA P.B./PANIC BAR P.C.P./PRECAST CONCRETE PANEL PERIM./PERIMETER PL./PLATE PL. G./PLATE GLASS PLAM./PLASTIC LAMINATE	R./RISER OR REFRIGERATOR (R)/REMOVE R.A./RETURN AIR RAD./RADIUS R.B./RUBBER BASE R.C.P./REFLECTED CEILING PLAN R.D./ROOF DRAIN REF./REFERENCE REF/REFRIGERATOR REFR./REFRIGERATION REINF./REINFORCED REQD./REQUIRED REV./REVISION OR REVISED RESIL./RESILIENT R.H./RIGHT HAND RM./ROOM R.O./ROUGH OPENING RWD./REDWOOD R.W.L./RAINWATER LEADER	S/SOUTH S.A./SUPPLY AIR S.B./SCOREBOARD S.C./SOLID CORE S.C.D./SEE CIVIL DRAWINGS or DIMENSION S.D./STORM DRAIN S.D.S./SEE DOOR SCHEDULE S.E./SOUTHEAST S.E.D./SEE ELECTRICAL DRAWINGS SECT./SECTION S.F./SQUARE FOOT (FEET) S.F.S./SEE (ROOM) FINISH SCHEDULE SHT./SHEET SHTG./SHEATHING SIM./SIMILAR S.L.D./SEE LANDSCAPE DRAWINGS S.M./SHEET METAL SL./SLOPE SMACNA /SHEET METAL AND	U.B.C./UNIFORM BUILDING
--	--	--	---	--	---	--	--	---	---	-------------------------

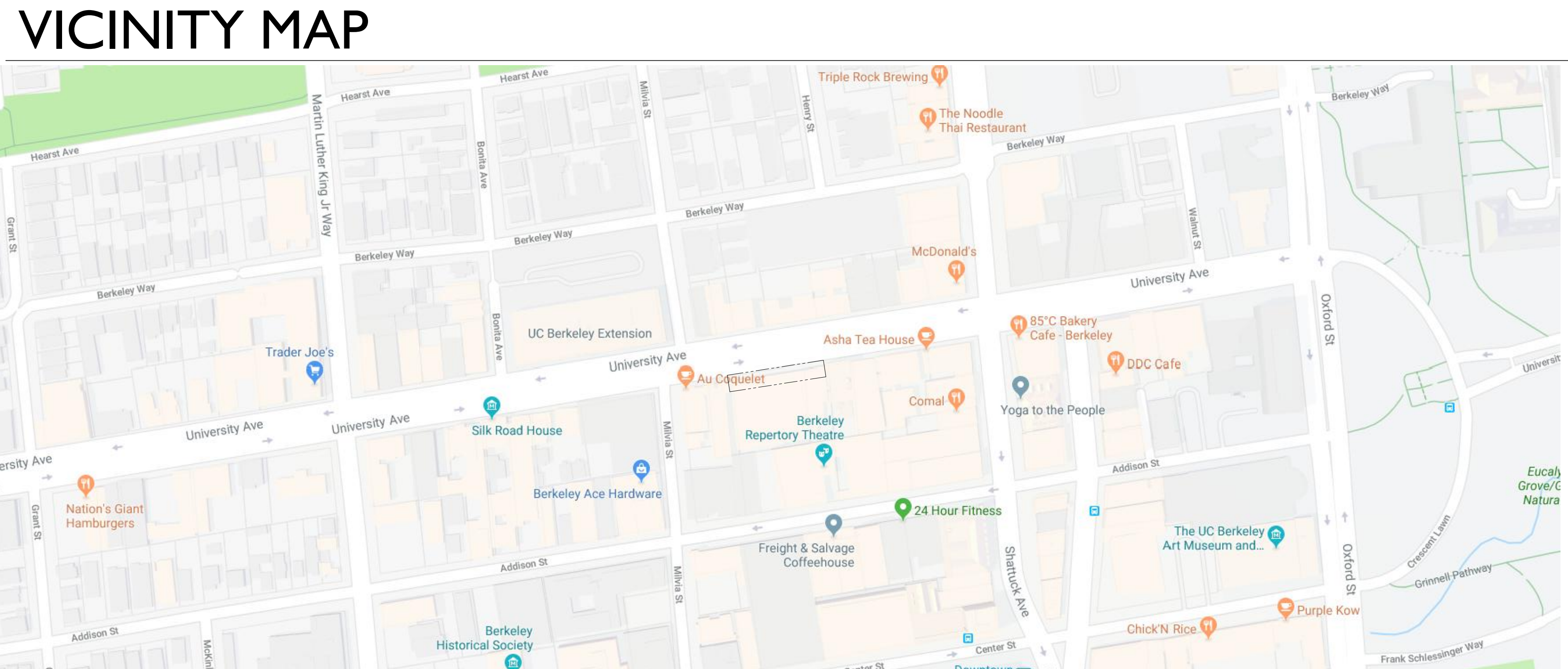

## SHEET INDEX

ARCHITECTURAL	T0.1 TITLE SHEET A0.1 SITE PLAN A1.0 EXISTING FIRST FLOOR PLAN A1.1 FIRST FLOOR IMPROVEMENT PLAN A3.0 EXISTING ELEVATIONS A3.1 IMPROVEMENT ELEVATIONS D1.0 DETAILS
---------------	--

**GUNKEL ARCHITECTURE**  
2295 SAN PABLO AVENUE  
BERKELEY CA 94702  
GUNKELARCHITECTURE.COM  
PHONE: (510) 984 - 1112

**EXTERIOR ELEVATION RENOVATION**  
2018-2030 UNIVERSITY AVE.  
BERKELEY, CA 94704

TITLE SHEET

L.P.C. SUBMITTAL

DATE 01/17/2019

**T0.1**



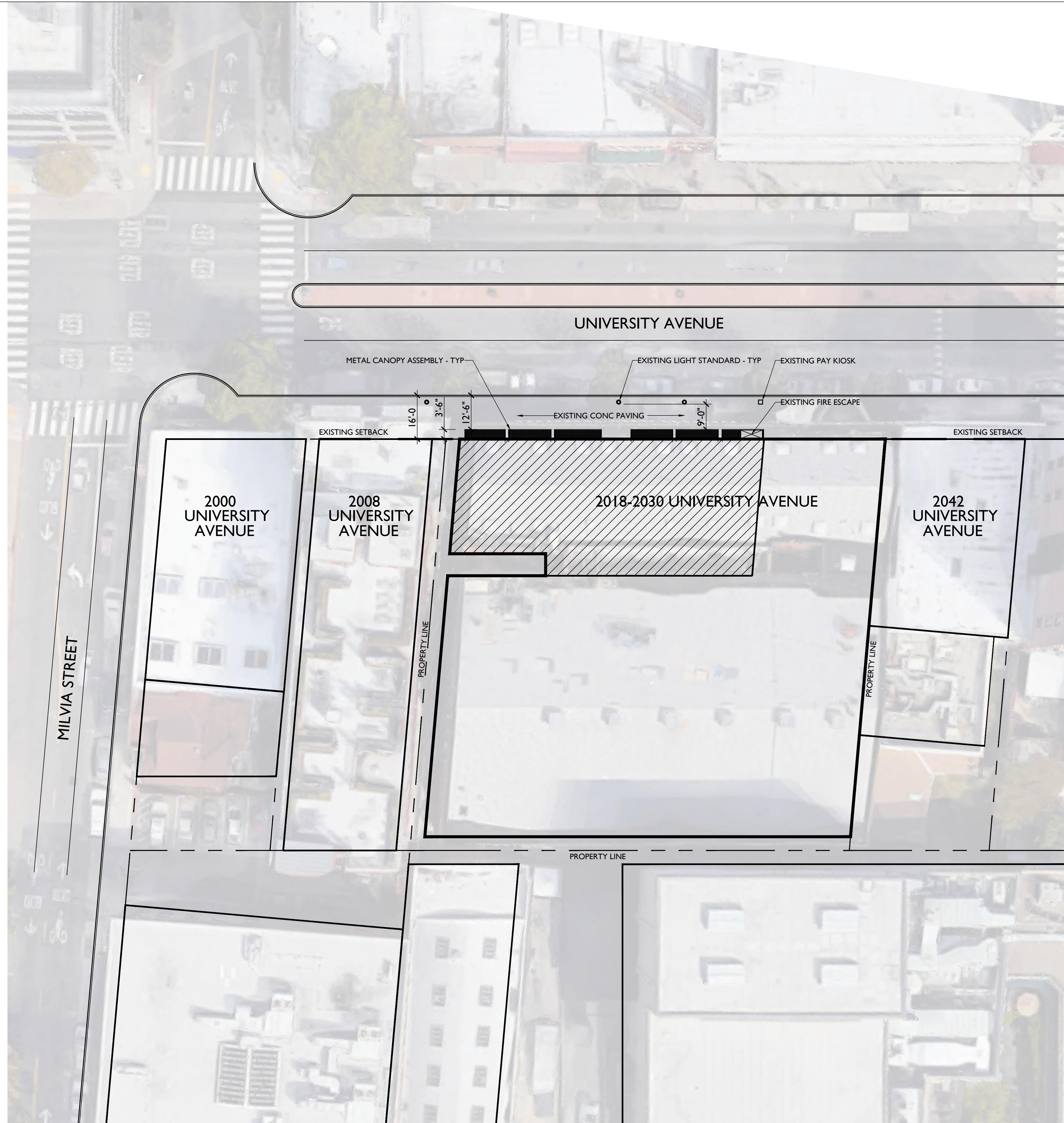

SITE PLAN

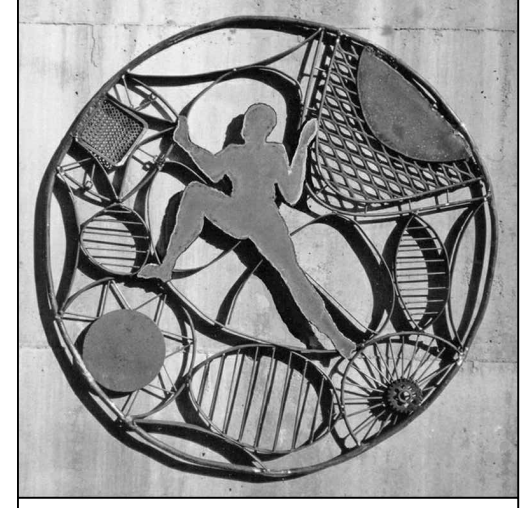
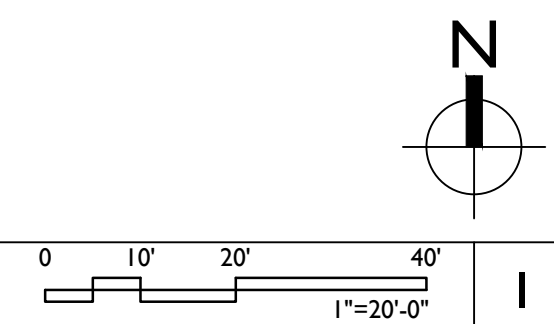

**GUNKEL ARCHITECTURE**  
 2295 SAN PABLO AVENUE  
 BERKELEY CA 94702  
 GUNKELARCHITECTURE.COM  
 PHONE: (510) 984 - 1112

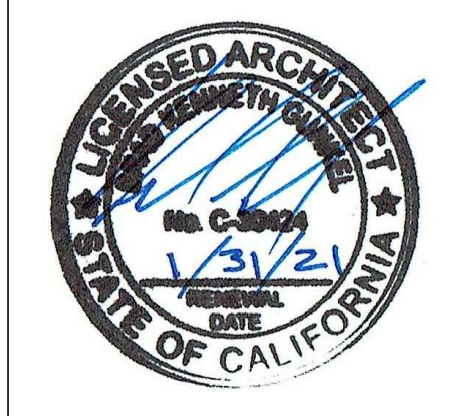

**EXTERIOR ELEVATION  
 RENOVATION**  
 2018-2030 UNIVERSITY AVE.  
 BERKELEY, CA 94704

SITE PLAN

L.P.C. SUBMITTAL

DATE 01/17/2019

**A0.1**



# DEMOLITION NOTES #

1. (E) CONC PAVING TO REMAIN
2. (E) STRUCTURAL STEEL BRACE FRAME TO REMAIN
3. REMOVE FLOORING MATERIAL WITHIN ALCOVE - PREP TO RECEIVE NEW FINISH
4. REMOVE DOOR ASSEMBLY
5. REMOVE WINDOW ASSEMBLY, INCLUDING WINDOW TREATMENT (BLINDS)
6. REMOVE CEILING ASSEMBLY WITHIN ALCOVE

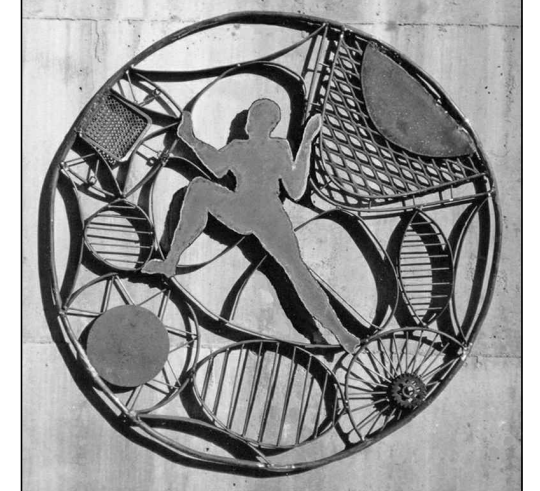

**GUNKEL ARCHITECTURE**  
2295 SAN PABLO AVENUE  
BERKELEY CA 94702  
GUNKELARCHITECTURE.COM  
PHONE: (510) 984 - 1112



**EXTERIOR ELEVATION RENOVATION**  
2018-2030 UNIVERSITY AVE.  
BERKELEY, CA 94704

FIRST FLOOR  
DEMOLITION  
PLAN

L.P.C. SUBMITTAL

DATE 01/17/2019

**A1.0**

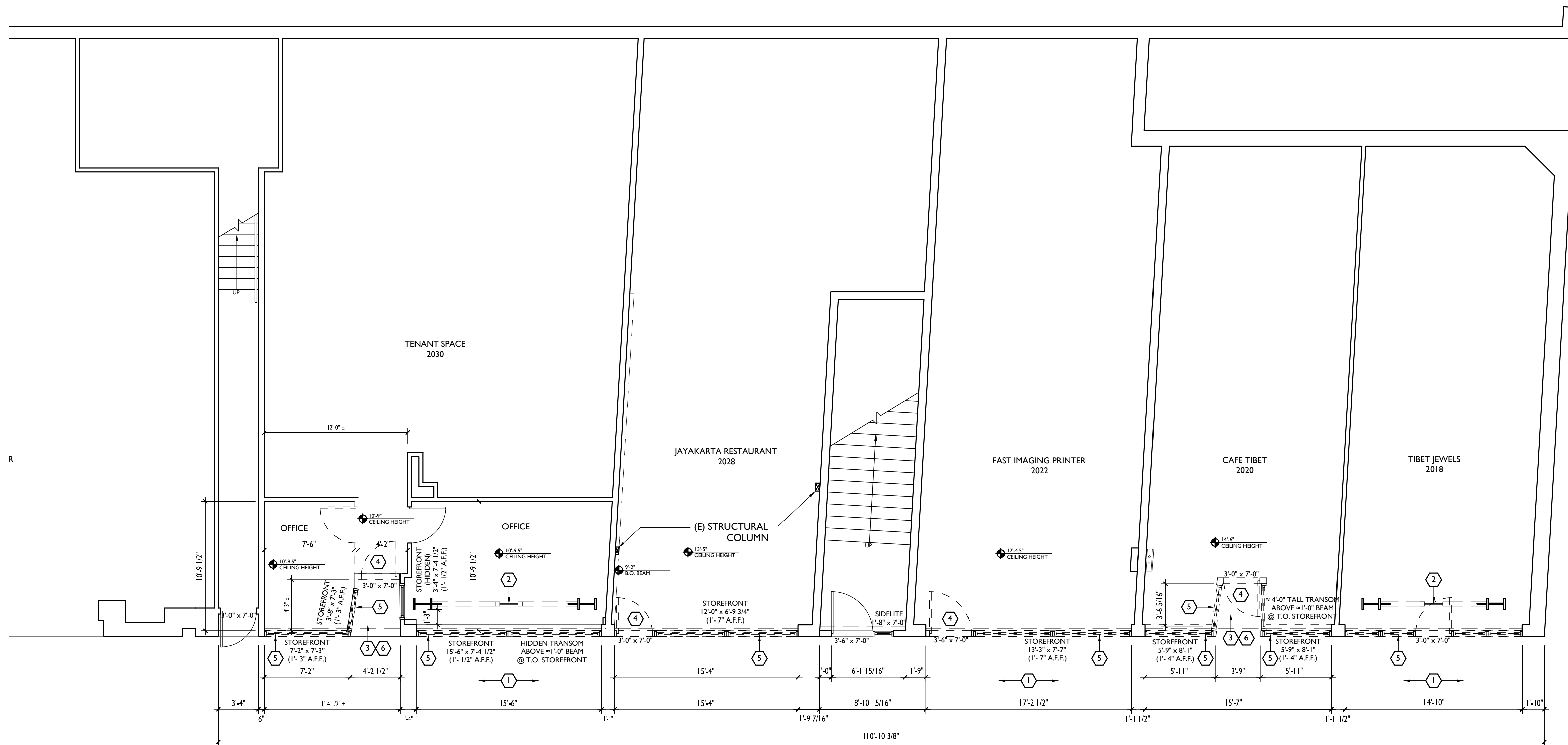

NOTE: REFER TO SHEET A3.0 FOR ADDITIONAL DEMOLITION SCOPE

FIRST FLOOR DEMOLITION PLAN

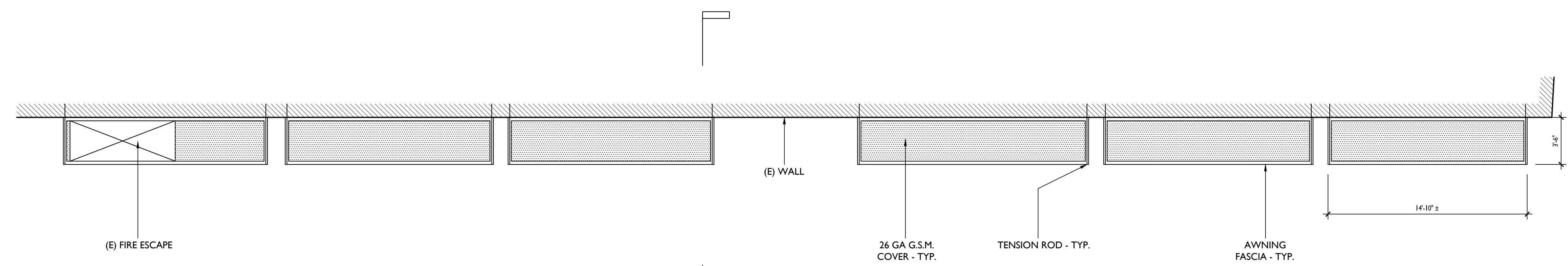

NOTE: NO AWNING INFILL ASSEMBLY BELOW FIRE ESCAPE

AWNING LEVEL PLAN

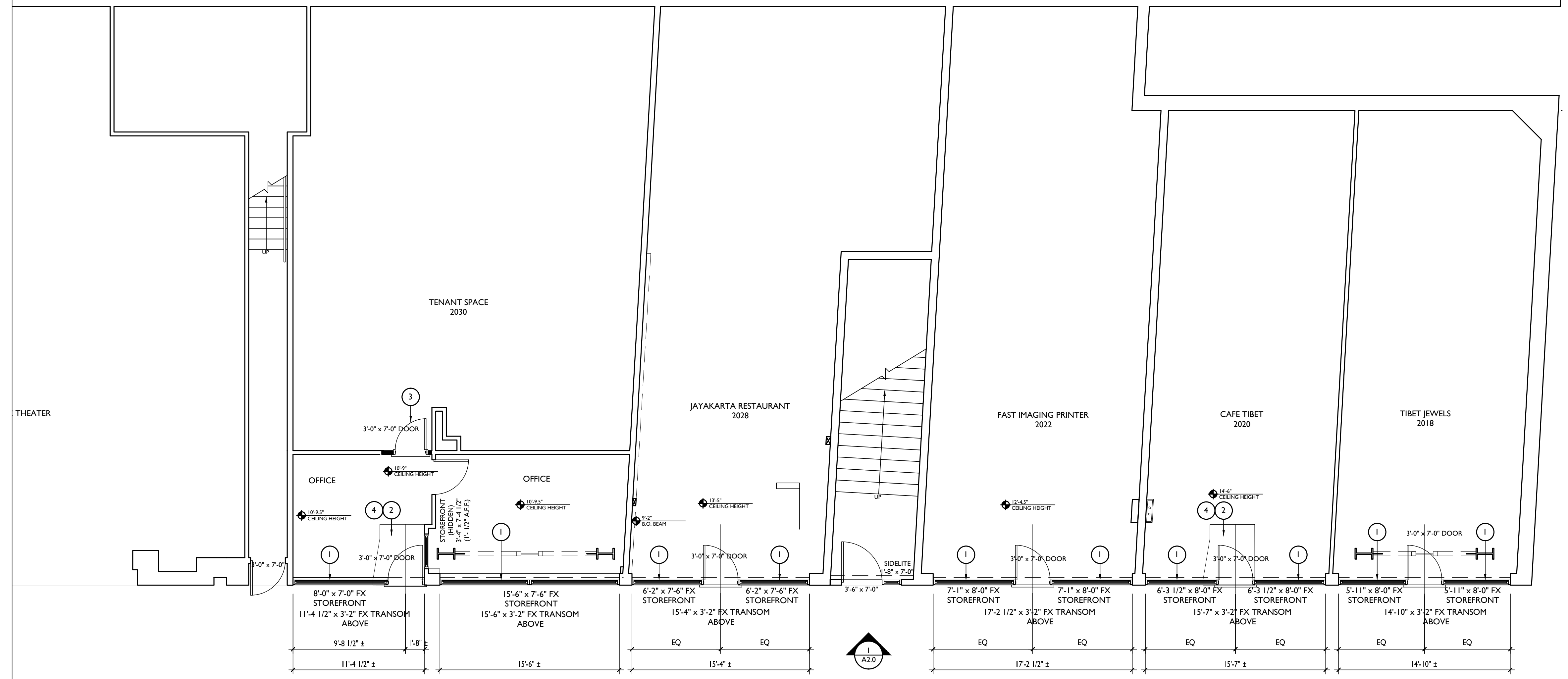
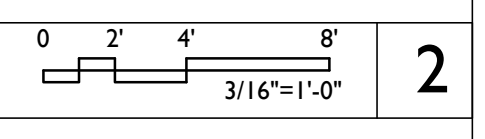

FIRST FLOOR IMPROVEMENT PLAN

CONSTRUCTION NOTES #

1. PONY WALL ASSEMBLY - 2x6 FRAMING @ 16" O.C. WITH 1/2" PLYWOOD EACH SIDE WITH FINISHES PER DETAILS & ELEVATIONS. RECONFIGURE / RE-ESTABLISH ELECTRICAL POWER WITHIN WALL
2. APPLY FLOORING - MATCH (E) ADJACENT
3. INFILL OPENING W/ DOOR AND WALL ASSEMBLIES - MATCH (E)
4. CONSTRUCT CEILING ASSEMBLY (AT NEW ELEVATION/MATCH (E) ADJACENT)

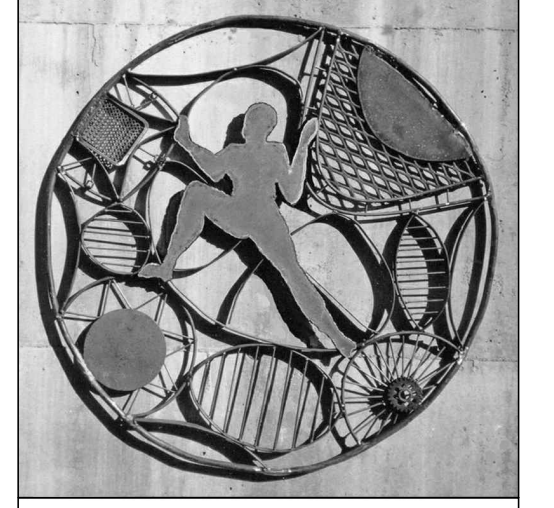

**GUNKEL ARCHITECTURE**  
2295 SAN PABLO AVENUE  
BERKELEY CA 94702  
GUNKELARCHITECTURE.COM  
PHONE: (510) 984 - 1112



**EXTERIOR ELEVATION RENOVATION**  
2018-2030 UNIVERSITY AVE.  
BERKELEY, CA 94704

FIRST FLOOR IMPROVEMENT PLAN

L.P.C. SUBMITTAL

DATE 01/17/2019

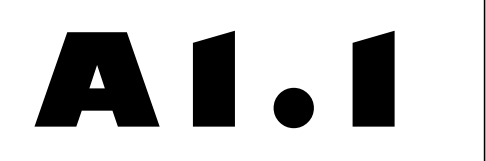



# DEMOLITION NOTES #

1. (E) DOOR ASSEMBLY TO REMAIN
2. REMOVE PAINT FROM (E) BRICK
3. (E) FIRE ESCAPE TO REMAIN
4. (E) WINDOW ASSEMBLY TO REMAIN
5. (E) BRICK TO REMAIN
6. (E) SPANDREL TO REMAIN
7. REMOVE WALL MOUNTED SIGN ASSEMBLY AND ASSOCIATED POWER SUPPLY AND CONDUITS
8. REMOVE ALL ABANDONED ELECTRICAL CONDUITS, BOXES, ETC.
9. REMOVE ELECTRICAL LIGHT FIXTURE AND ASSOCIATED CONDUCTORS, BOXES, CONDUITS, ETC.
10. REMOVE SECURITY CAMERA
11. REMOVE AWNING ASSEMBLY
12. REMOVE BUILDING SIGN
13. REMOVE SECURITY GRILLE
14. REMOVE DOOR ASSEMBLY
15. REMOVE WINDOW ASSEMBLY
16. REMOVE PONY WALL ASSEMBLY
17. REMOVE APPLIED FINISHES TO EXPOSE (E) BRICK
18. REMOVE APPLIED FINISHES TO EXPOSE (E) BRICK
19. REMOVE APPLIED FINISH TO EXPOSE ORIGINAL COLUMN COVERING
20. REMOVE FRAMED SPANDREL INFILL ASSEMBLY
21. REMOVE LOUVER ASSEMBLY
22. (E) LIGHT FIXTURE TO REMAIN
23. REMOVE FAN ASSEMBLY

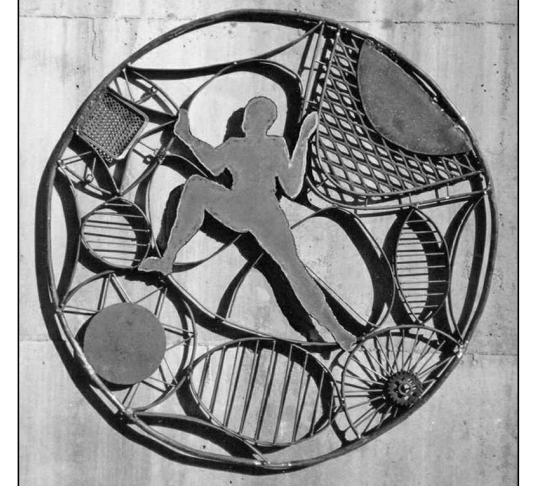

**GUNKEL ARCHITECTURE**  
 2295 SAN PABLO AVENUE  
 BERKELEY CA 94702  
 GUNKELARCHITECTURE.COM  
 PHONE: (510) 984 - 1112

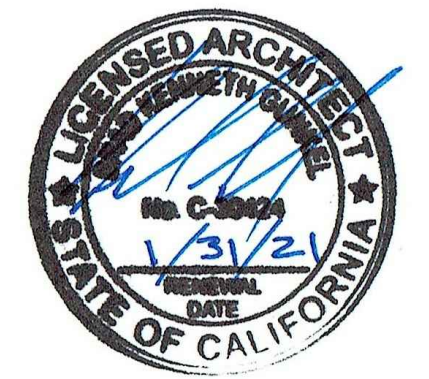

**EXTERIOR ELEVATION RENOVATION**  
 2018-2030 UNIVERSITY AVE.  
 BERKELEY, CA 94704

DEMOLITION ELEVATION

L.P.C. SUBMITTAL

DATE 01/17/2019

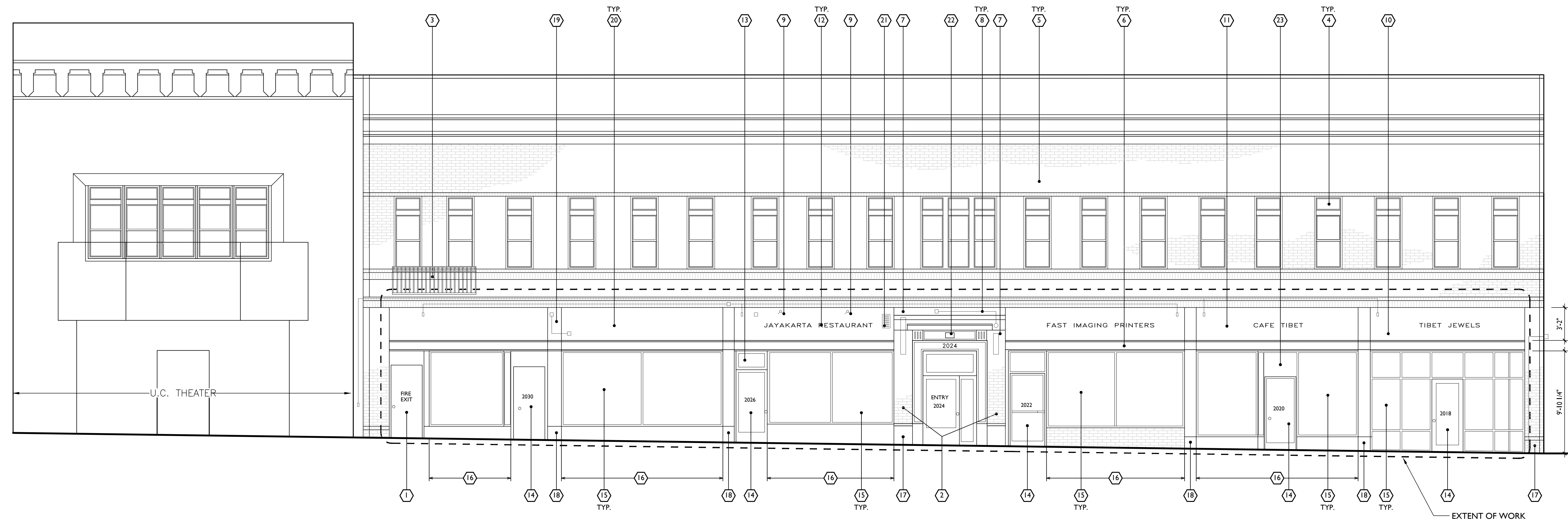

NOTE: REFER TO SHEET A1.0 FOR ADDITIONAL DEMOLITION SCOPE

DEMOLITION ELEVATION

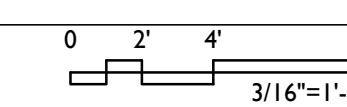

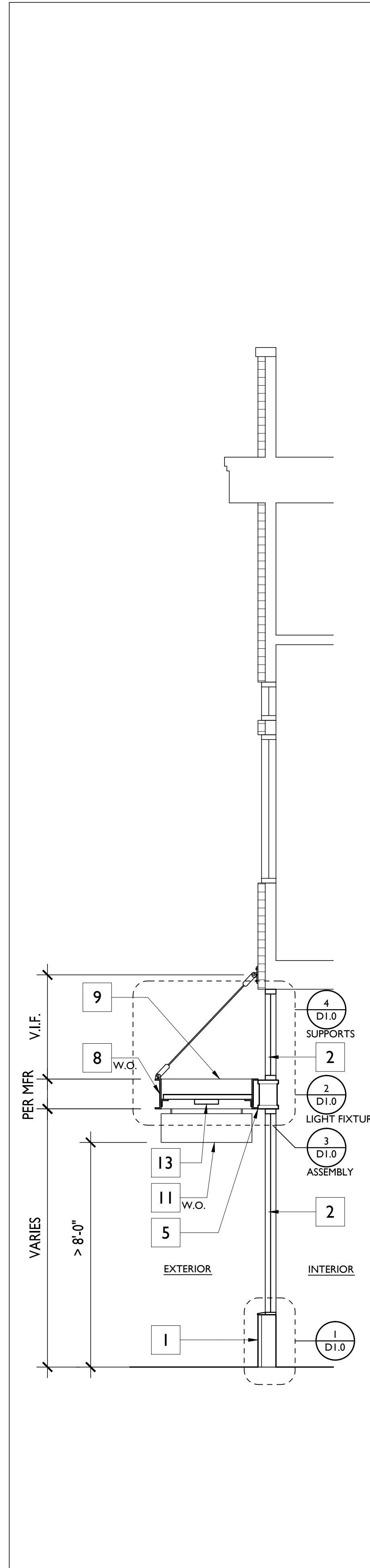

1. APPLY FINISH ASSEMBLY TO PONY WALL: CERAMIC TILE (4 COLOR PATTERN) SET ON THINSET MORTAR OVER CEMENTITIOUS BACKER BOARD
2. INSTALL ALUMINUM STOREFRONT WINDOW ASSEMBLY: MFR - US ALUMINUM; SERIES 400 WITH DARK BRONZE ANODIZED FINISH (UC74957), CENTER GLAZED (1/4" TEMPERED GLASS), OR EQUAL
3. INSTALL ALUMINUM STOREFRONT DOOR ASSEMBLY: MFR - US ALUMINUM; SERIES 400 WITH DARK BRONZE ANODIZED FINISH (UC74957), OFFSET HUNG DOOR, OR EQUAL
4. INSTALL ALUMINUM LOUVER ASSEMBLY: 2" DEEP FULL LITE INFILL LOUVER, INCLUDING HEAD AND SILL FLASHING
5. EXISTING COLUMN/SPANDREL TO REMAIN: REPAIR/REFURBISH TO MATCH EXISTING TRIMMED CONFIGURATION. PREP AND PAINT
6. EXISTING DOOR ASSEMBLY INCLUDING FRAME AND TRANSOM TO REMAIN, PREP AND PAINT
7. EXISTING DOOR ASSEMBLY INCLUDING FRAME, TRANSOM, AND SIDE LITE TO REMAIN, PREP AND PAINT
8. AWNING SIGNAGE: CHARACTERS 6" HIGH (50% OF OVERALL VERTICAL HEIGHT OF AWNING), 3" FROM TOP AND BOTTOM FLANGES.
9. INSTALL ALUMINUM AWNING ASSEMBLY: MFR - C.R. LAURENCE; C-SHAPED ALUMINUM FASCIA, CATALOG NUMBER: CANCSIC WITH 12MM DIAMETER S.S. TENSION RODS, CATALOG NUMBER: 270112CR B.S. ENDS, CATALOG NUMBER: 270112 B.S. DIAMOND SHAPED MOUNTING PLATES, CATALOG NUMBER: AW9DM B.S. INFILL AWNING WITH METAL DECK: MFR - VERCO DECKING; 1-5/16" DEEP, 24 GAUGE GALVANIZED ROOF DECK
10. RE-GROUT MORTAR JOINT AND APPLY SEALER TO BRICK PIER
11. AWNING MOUNTED PROJECTING SIGNAGE: 3" THICK MAX/3.5 S.F. MAX ALLOWED PER BUSINESS
12. DOUGLAS FIR WOOD DOOR - 1'-6" BOTTOM RAIL W/ 6" STILES & 8" TOP RAIL
13. INSTALL AWNING MOUNTED LIGHT FIXTURE: MFR - ACCESS LIGHTING; ULKO EXTERIOR LED OUTDOOR ROUND FLUSHMOUNT, BRONZE FINISH, 9" SQUARE, 19 WATT, 3000K, OR EQUAL
14. EXISTING ENTRY WAY TO REMAIN. REPAIR/REFURBISH FINISHES, PREP AND PAINT
15. EXISTING COLUMN BASE TO REMAIN. REPAIR/REFURBISH FINISHES, PREP AND PAINT
16. EXISTING FIRE ESCAPE TO REMAIN

CONSTRUCTION NOTES

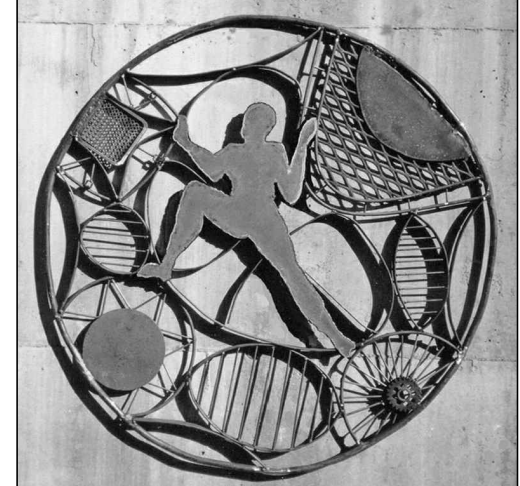
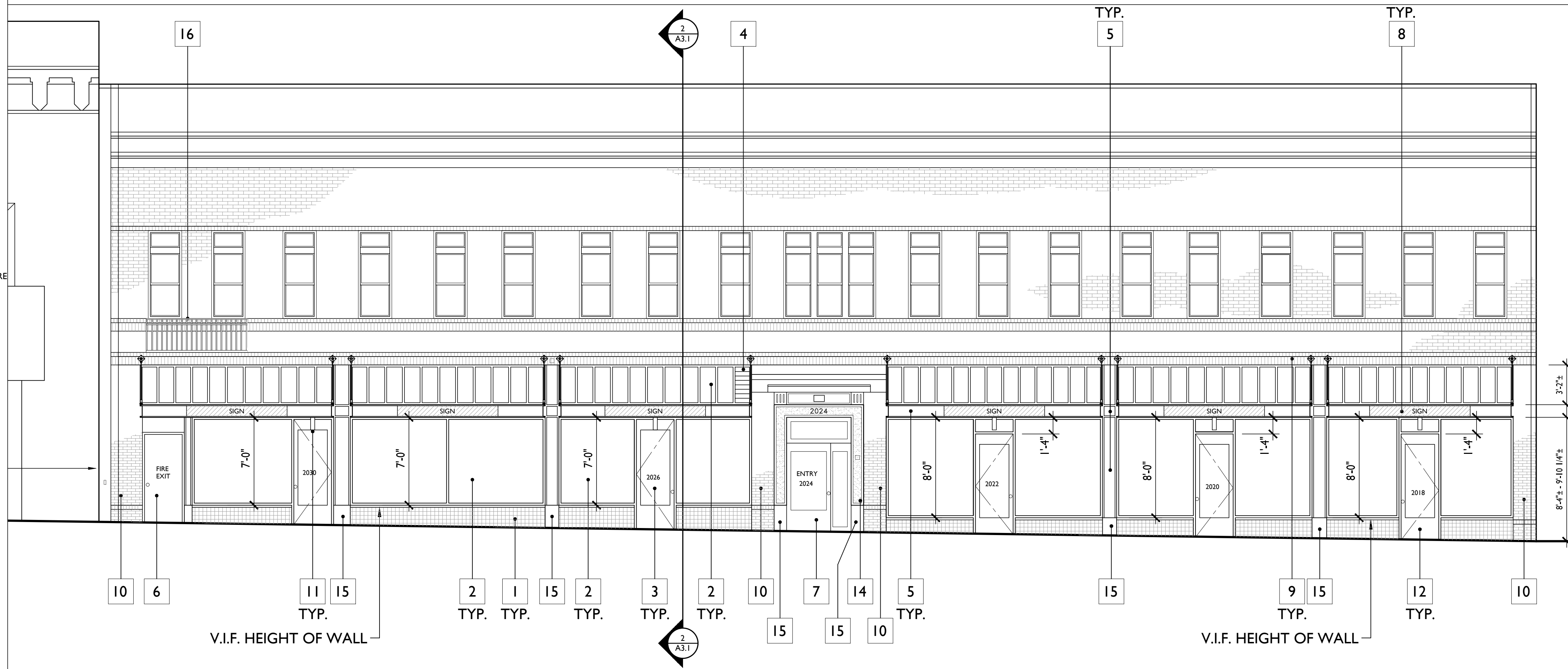

**GUNKEL ARCHITECTURE**  
2295 SAN PABLO AVENUE  
BERKELEY CA 94702  
GUNKELARCHITECTURE.COM  
PHONE: (510) 984 - 1112



**EXTERIOR ELEVATION  
RENOVATION**  
2018-2030 UNIVERSITY AVE.  
BERKELEY, CA 94704

IMPROVEMENT  
ELEVATION

L.P.C. SUBMITTAL

DATE 01/17/2019





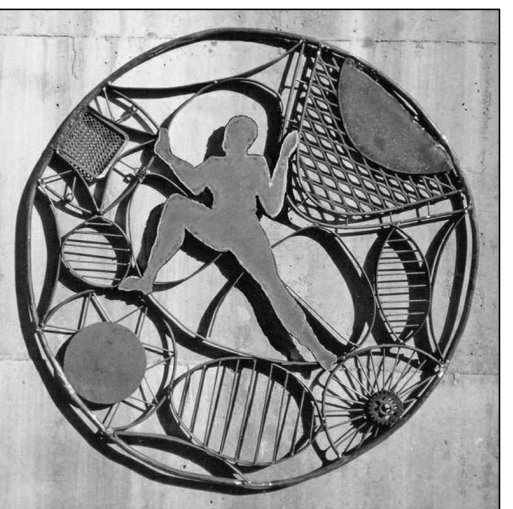
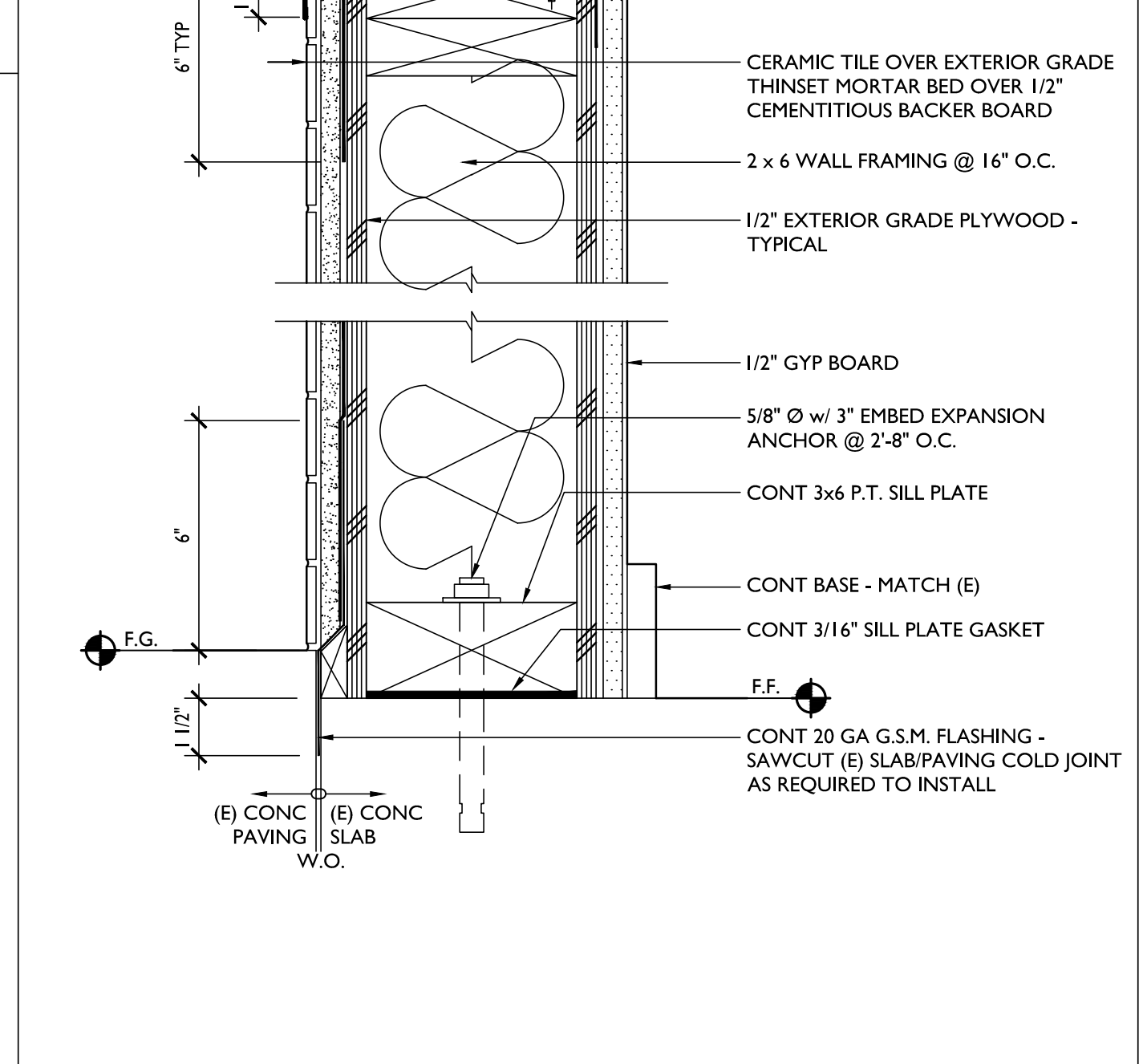
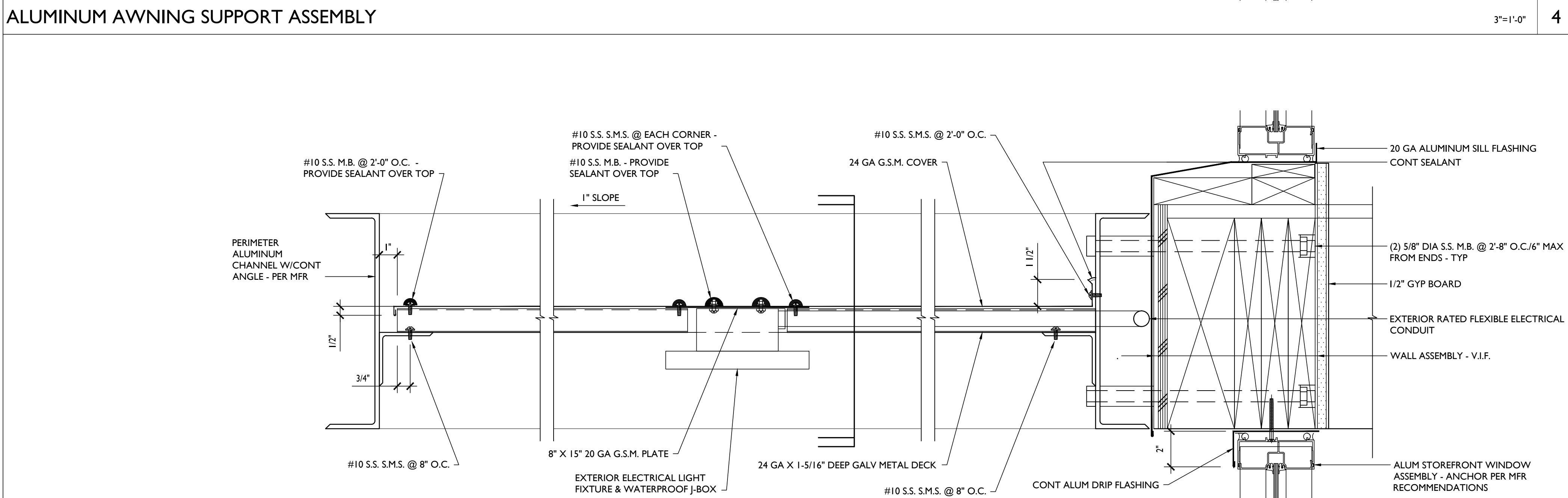
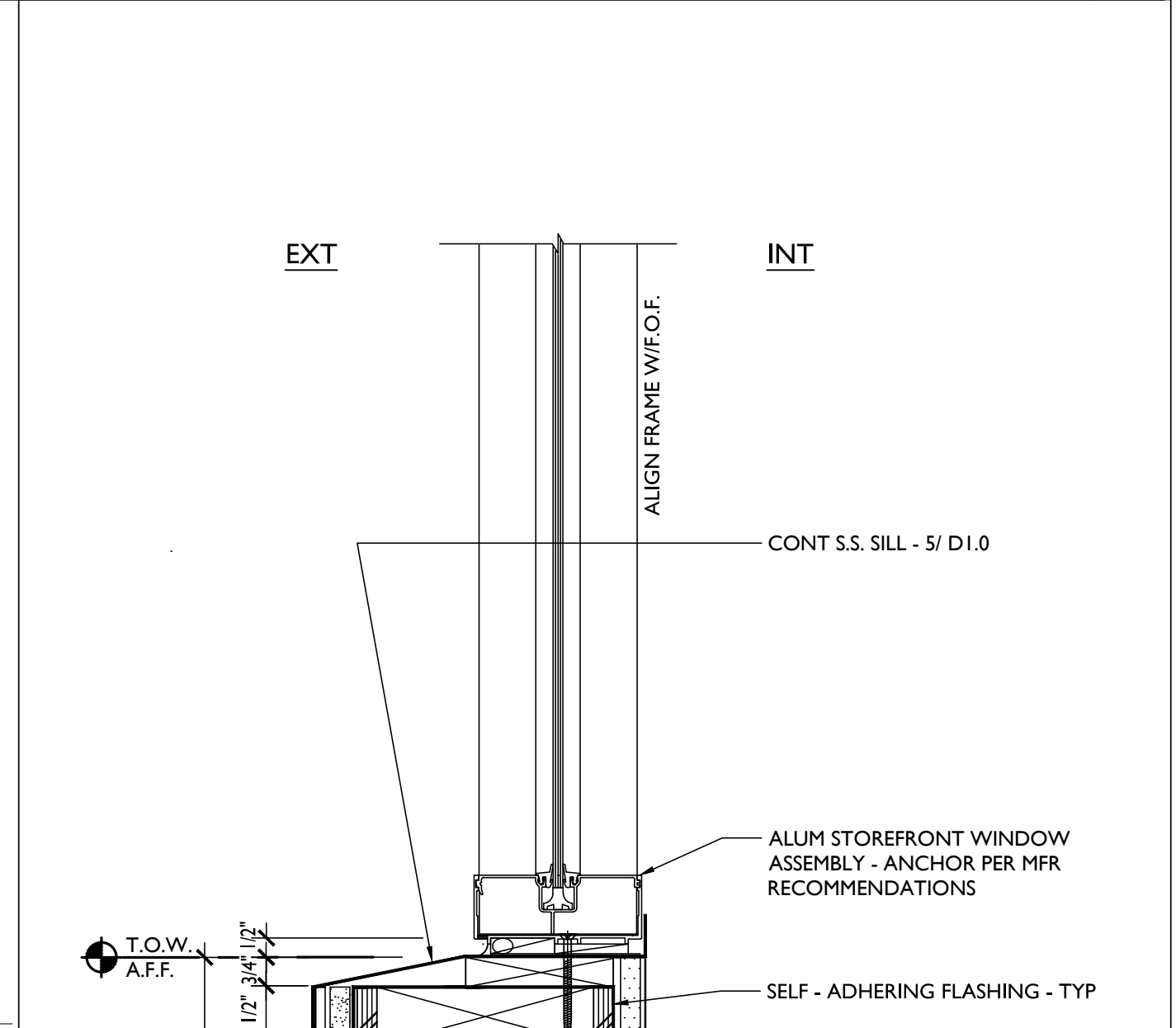
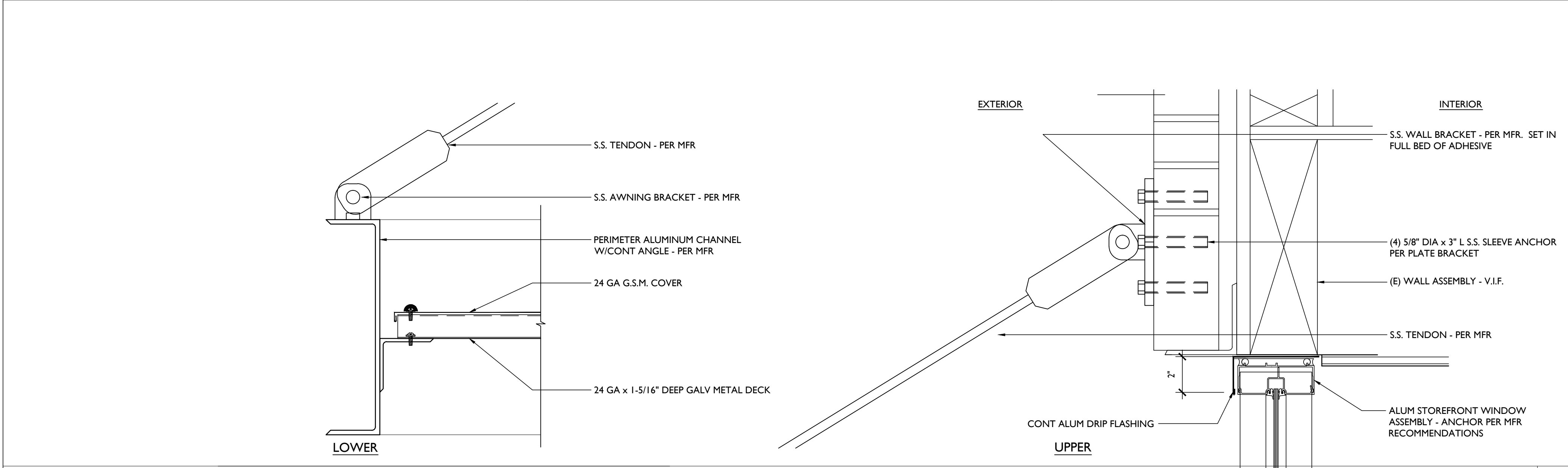
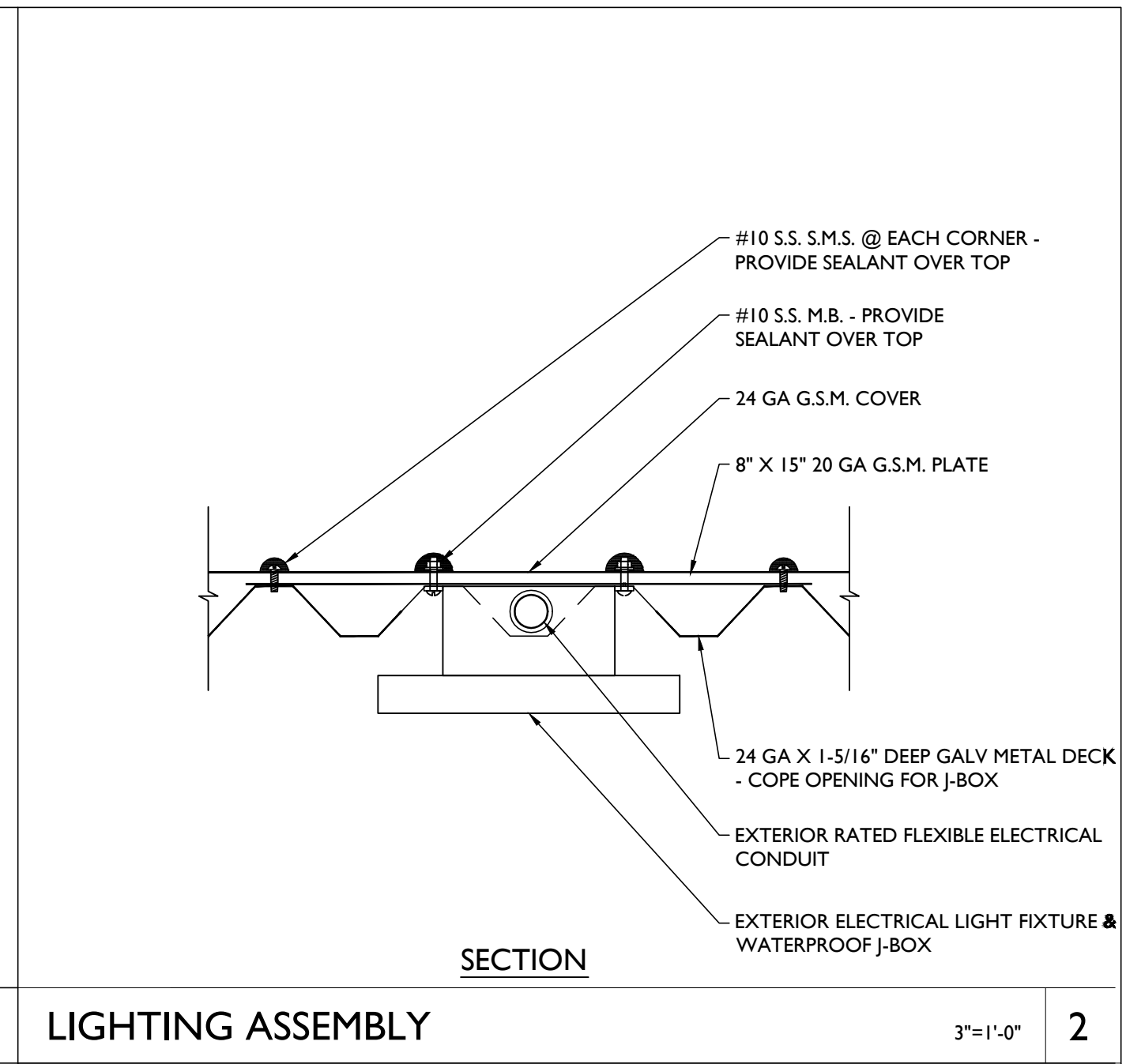
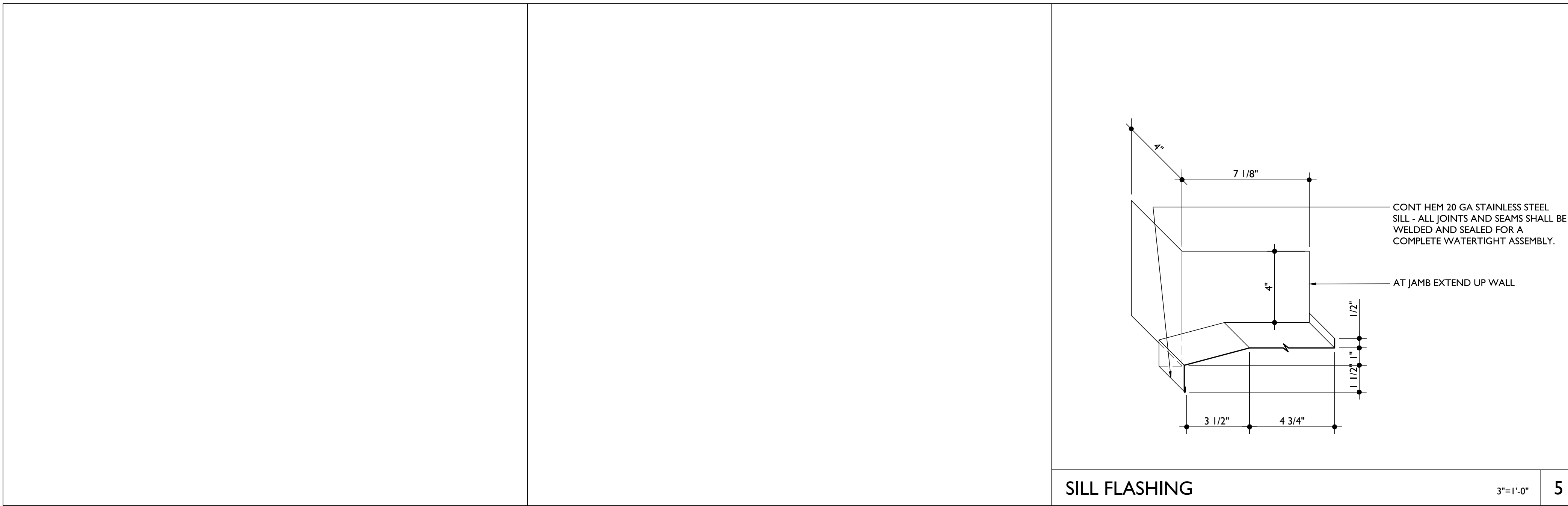

**GUNKEL ARCHITECTURE**  
2295 SAN PABLO AVENUE  
BERKELEY CA 94702  
GUNKELARCHITECTURE.COM  
PHONE: (510) 984 - 1112



**EXTERIOR ELEVATION RENOVATION**  
2018-2030 UNIVERSITY AVE.  
BERKELEY, CA 94704

**DETAILS**

L.P.C. SUBMITTAL

DATE 01/17/2019

**D1.0**



LIGHT FIXTURE



AWNING

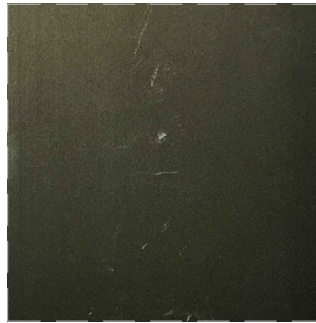

1 STOREFRONT & AWNING  
(DARK BRONZE ALUMINUM)

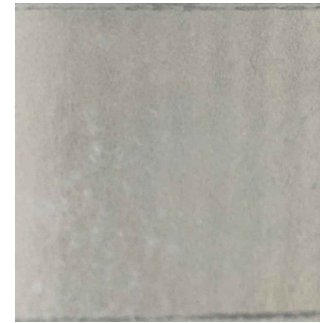

2 AWNING CEILING  
(GALVANIZED METAL)

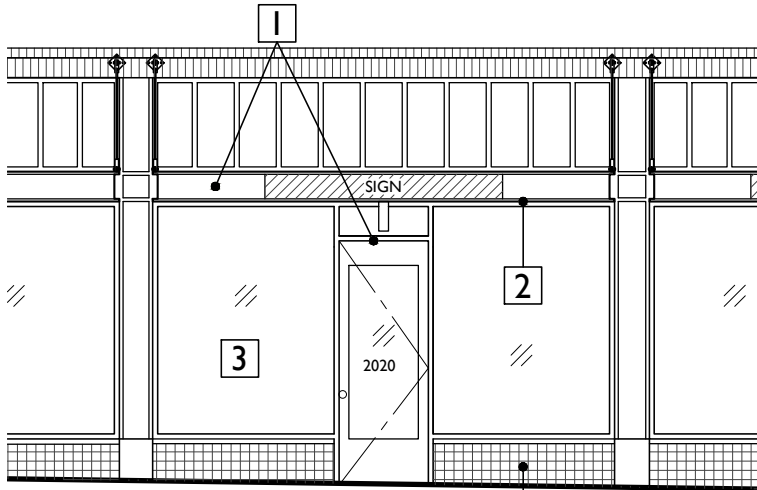
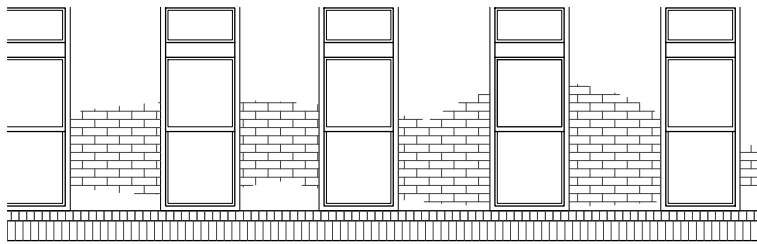

TYPICAL EXTERIOR ELEVATION

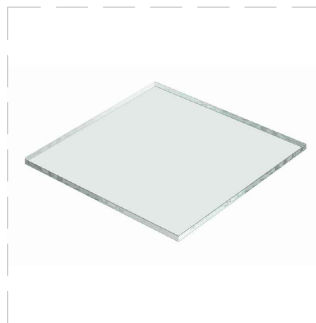

3 GLAZING  
(CLEAR TEMPERED)



4 TILE  
(DARK BROWN, MEDIUM BROWN,  
LIGHT BROWN & BEIGE)

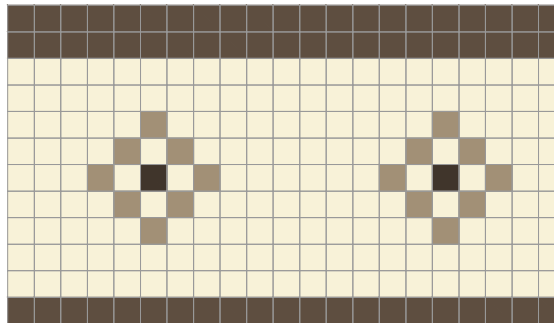

TILE PATTERN

2018-2030 UNIVERSITY AVENUE - EXTERIOR ELEVATION RENOVATION: MATERIAL SELECTION

GUNKEL ARCHITECTURE  
2295 SAN PABLO AVENUE  
BERKELEY CA 94702  
GUNKELARCHITECTURE.COM  
PHONE: (510) 984 - 1112

